

# RESEARCH & REVIEWS IN AGRICULTURE, FORESTRY AND AQUACULTURE

*December 2022*

Editor

Prof. Dr. Taner AKAR

**gece**  
kitaplığı

**İmtiyaz Sahibi / Publisher • Yaşar Hız**  
**Genel Yayın Yönetmeni / Editor in Chief • Eda Altunel**  
**Kapak & İç Tasarım / Cover & Interior Design • Gece Kitaplığı**  
**Editörler / Editors • Prof. Dr. Taner AKAR**  
**Birinci Basım / First Edition • © Aralık 2022**  
**ISBN • 978-625-430-562-7**

**© copyright**

Bu kitabın yayın hakkı Gece Kitaplığı'na aittir.

Kaynak gösterilmeden alıntı yapılamaz, izin  
almadan hiçbir yolla çoğaltılamaz.

The right to publish this book belongs to Gece Kitaplığı.

Citation can not be shown without the source, reproduced in any way  
without permission.

**Gece Kitaplığı / Gece Publishing**

**Türkiye Adres / Turkey Address:** Kızılay Mah. Fevzi Çakmak 1. Sokak

Ümit Apt. No: 22/A Çankaya / Ankara / TR

**Telefon / Phone:** +90 312 384 80 40

**web:** [www.gecekitapligi.com](http://www.gecekitapligi.com)

**e-mail:** [gecekitapligi@gmail.com](mailto:gecekitapligi@gmail.com)



**Baskı & Cilt / Printing & Volume**

Sertifika / Certificate No: 47083

# **Research & Reviews in Agriculture, Forestry and Aquaculture**

**December 2022**

Editor

Prof. Dr. Taner AKAR



# CONTENTS

## **CHAPTER 1**

### **THE AQUATIC ZOOPLANKTON DAPHNIA MAGNA'S INFLUENCE ON GROWTH AND REPRODUCTION PERFORMANCE IN THE DIFFERENT WAYS OF USING COMMERCIAL OATH WITH CHLORELLA SOROKINIANA**

*Çetin YAĞCILAR, Halime PEHLİVANOĞLU, Ulaş Başar BAŞEL,  
Barış Emir ERDOĞAN..... 1*

## **CHAPTER 2**

### **ZOOPLANKTON OF A FRESHWATER BODY (ELAZIG CITY SAMPLE-TURKEY)**

*Hilal BULUT..... 17*

## **CHAPTER 3**

### **ROLE OF BIO – ACTIVE COMPOUNDS TO PREVENT OXIDATIVE DAMAGE IN MAIZE**

*Seher ÖZKAN, Elif ÖZDEMİR..... 31*

## **CHAPTER 4**

### **SMART FARMING APPLICATION IN FRUIT HARVESTING**

*M. Barış EMİNOĞLU, Uğur YEGÜL..... 45*

## **CHAPTER 5**

### **TRADITIONAL CENTENNIAL FLAVOR: SİLİVRİ YOGURT**

*Seval Sevgi KIRDAR..... 59*

**CHAPTER 6**

**FROM CLIMATE CHANGE ADAPTATION STRATEGIES;  
ORGANIC FARMING**

*Sevinç BAŞAY*.....81

**CHAPTER 7**

**A REVIEW OF UTILIZATION OF LAMINARIN,  
ALGINATE, AND FUCOIDAN POLYSACCHARIDES  
FROM MACROALGAE FOR PROMOTING GROWTH  
PERFORMANCE AND HEALTH IN AQUATIC ORGANISMS**

*Metin YAZICI, Mehmet NAZ, Yavuz MAZLUM*.....89

**CHAPTER 8**

**USING GIS TO CREATE A FOREST ROAD NETWORK**

*Metin TUNAY, Salih KUVVETLİ* .....107

**CHAPTER 9**

**ASSESSMENT OF TRACE ELEMENTS POLLUTION LEVELS  
IN SEDIMENTS AND OF ENVIRONMENTAL, ECOLOGICAL  
AND HUMAN HEALTH RISK BY SOME QUALITY INDICES-  
A REVIEW**

*Özgür CANPOLAT, Memet VAROL, Metin ÇAĞLAR*.....121

**CHAPTER 10**

**ENRICHMENT OF VERMICOMPOST BY PLANT GROWTH  
PROMOTING BACTERIA**

*Mustafa CERITOGLU, Murat ERMAN*.....139

**CHAPTER 11**

**SILICON FERTILIZATION TO OVERCOME BIOTIC AND  
ABIOTIC STRESS FACTORS**

*Elif ÖZDEMİR*.....157

**CHAPTER 12**

**A REVIEW OF THE WORLD'S WHEY CHEESES**

*Seval Sevgi KIRDAR*.....173





# **CHAPTER 1**

## **THE AQUATIC ZOOPLANKTON DAPHNIA MAGNA'S INFLUENCE ON GROWTH AND REPRODUCTION PERFORMANCE IN THE DIFFERENT WAYS OF USING COMMERCIAL OATH WITH CHLORELLA SOROKINIANA**

*Çetin YAĞCILAR<sup>1</sup>, Halime PEHLİVANOĞLU<sup>2</sup>,  
Ulaş Başar BAŞEL<sup>3</sup>, Barış Emir ERDOĞAN<sup>4</sup>*

1 Çetin YAĞCILAR, Dr.,Tekirdağ Namık Kemal University Faculty of Veterinary Medicine, <https://orcid.org/0000-0002-4683-820X>

2 Halime PEHLİVANOĞLU,Asst.Prof.Dr.,Tekirdağ Namık Kemal University Faculty of Veterinary Medicine, <https://orcid.org/0000-0003-3138-9568>

3 Ulaş Başar BAŞEL,Undergraduate student, Tekirdağ Namık Kemal University Faculty of Arts and Sciences Department of Biology, <https://orcid.org/0000-0001-8814-2174>

4 Barış Emir ERDOĞAN,Undergraduate student, Tekirdağ Namık Kemal University Faculty of Arts and Sciences Department of Biology, <https://orcid.org/0000-0001-9197-3622>

## Introduction

Living organisms referred to as animal plankton in the aquatic environment are classified as primary consumers (Setyawan vd., 2022). *Daphnia magna* from this animal plankton has been used in many studies but has not lost popularity in feeding studies. *Daphnia magna* is a small planktonic mollusk (Khan vd., 2020, Munirasu, etc., 2016), which belongs to the family “Daphnidae” and is called water flea. The use of this animal plankton in aquaculture is an important food source for fish, and special culture techniques are required to grow them (Herliwati vd., 2021). They are used to feed the adult fish and chicks of fish and shrimp species that are important for farming (Munirasu vd., 2016). The use of aquatic organisms is mainly a nutritious live food because it contains 45-70% more protein and has an oil content of 11-27% (Fouzi vd., 2021). Therefore, feeding daphnia cultures with insufficient nutrient resources is considered the most important factor affecting the amount of life in the environment (Djalil vd., 2020). They can also respond rapidly to increased or decreased population density in the medium, depending on the type, quality, and quantity of food contained in the environment (Munirasu vd., 2016). *Daphnia magna* culture reproduction under healthy conditions is parthenogenic and is constantly produced as female individuals (Kato & Watanabe, 2022).

Chlorella microalgia, which is included in the study in solid and liquid form, is one of the most commonly cultured algae after Spirulina and has a green color due to the chloroplasts. This microalga has high antioxidant capacity with chlorophyll as well as significant content of proteins, carbohydrates, lipids, vitamin C,  $\beta$ -carotene, vitamins B<sub>1</sub>, B<sub>2</sub>, B<sub>6</sub>, and B<sub>12</sub>, and dietary fiber (McCarty vd., 2009, Watanabe, 2007). Therefore, there is potential for its wide use in dietary supplements, clinical treatments, detoxification of heavy metals in wastewater, and cosmetics (Yaakob vd., 2014). It is an important source of protein as its protein content is 48-60%. More than 50% of its dry weight is protein, with more than 50% of these proteins forming intracellular proteins. It also contains all nine basic amino acids (Safi vd., 2014, Krimpen, vd., 2013, Ursu, etc., 2014). The fat content ranges from 10% to 53%, depending on the production conditions and the nutritional environment used. Most fatty acids consist of fatty acids with 18 and 16 carbon atoms. Omega 3 and omega 6 are abundant. It is a good source of iron and vitamin C. It contains a small amount of magnesium, zinc, copper, potassium, calcium, folic acid and other B vitamins (Panai vd., 2012). A study on the immune system in healthy people shows positive effects on the immune system (Kwak vd., 2012). It has also been found to contribute positively to lowering blood lipids and cholesterol levels due to fiber, niacin, carotenoids, and antioxidants (Panai vd., 2016, Fady, and 2012).

The aim of this study is to evaluate the growth, egg count and reproductive output of a solid and liquid microalgae species (*Chlorella sorokiniana*) grown in our laboratory and mixed with a commercial feed of the animal plankton species *Daphnia magna*.

## Materials and Methods

### *Daphnia magna* culture

*Daphnia magna* Tekirdag Namik Kemal University Veterinary School of Water Products Laboratory has been produced for more than three years. The *D. magna* culture is maintained in stock tanks with a total size of 80x60x35 cm in a dark cycle with 16 hours of light and 8 hours in the laboratory with an average water temperature of 24 °C and automatic lighting. In the stock aquaria, the daphnia are fed once a day with a commercial bait mixture and microalgae species (*Chlorella sorokiniana*, *Scenedesmus obliquus*).

### Experimental design

The 250 newborn chicks selected for the study were placed in a glass aquarium measuring 30x30x30 cm. After a week of acclimation, the daphnia that could not have eggs in the bag were separated and placed in boxes (15x30x10 cm) made of plastic material, then 15 units and 3 wheels with a thin pipette (3ml). In each box, 3 liters of water are put for the daphinas. For the study, three different bait forms were created; control (Inve O. RANGE start 200-300 microns), Inve O. RANGE start 200-300 microns+dried powder 5% *Chlorella sorokiniana*, Inve O. RANGE start 200-300 microns+liquid live *Chlorella sorokiniana* (Figure 1) culture is given. The work was continued for a total of 25 days. *Daphnia* water was changed daily and baits were placed 1 time per day after water change. During the water change, the organisms found in the canisters were collected and separated according to the number of newborn juveniles. *D. magna* measurements were taken every three days using a SOIF microscope to count length-to-width measurements and egg counts using ocular meters.

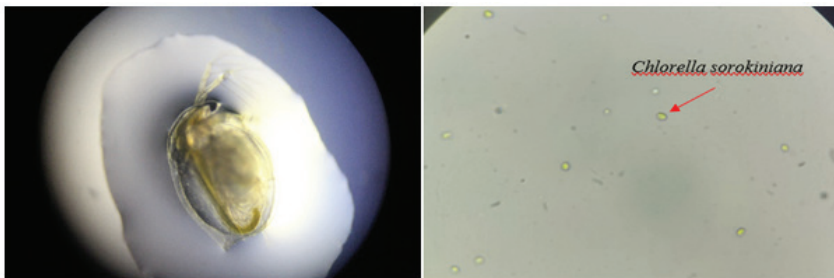

Figure 1. *Daphnia magna*, microscopic image of *Chlorella sorokiniana*

### Feed Preparation

*Daphnia magna* feeds by filtering microscopic bait from the water (Ocampo vd., 2010). Therefore, all *Daphnia* tanks are heavily aerated so that the bait can be adequately utilized. This zooplankton species can use many types of algae, yeast products, and water-soluble commercial food pellets as nutrients. In this case, three different forms of bait were used. First, commercial feed was fed to the *Daphnas*, dissolved in 0.1 g and 10 ml of water; second, commercial feed was dissolved in 5% chlorella dry form, 0.1 gram 10 ml of water each; and third, 0.1 gram commercial feed, 10 ml live chlorella culture was added and the *Daphnas* were fed once daily (Figure 2).



Figure 2. The feed forms used in the study

### *Chlorella sorokiniana* cultures

In our study, the added microalgae culture is *Chlorella sorokiniana* in the commercial form. First of all, the *Chlorella sorokiniana* microalgae cultivated in our laboratory was cultured in five-litre plastic bottles, three of them. The F/2 culture environment was used as the growth medium (Table 1).

Table 1. *Chlorella sorokiniana* F/2 medium

Component	Chemical compositions (g/L)	
<i>Salt solutions</i>		
NaNO <sub>3</sub>	300	
KH <sub>2</sub> PO <sub>4</sub>	30	
NH <sub>4</sub> Cl	20	
* The mixture should be dissolved in 1 liter of dH <sub>2</sub> O and kept in an autoclave at 120 °C for 30 minutes and then cooled.		
<i>Trace metal solutions</i>		
Solutions A		Stock Solutions (ml/L)
ZnSO <sub>4</sub> ·H <sub>2</sub> O	30	10 ml
CuSO <sub>4</sub> ·5H <sub>2</sub> O	25	
CuSO <sub>4</sub> ·H <sub>2</sub> O	30	
MnSO <sub>4</sub> ·H <sub>2</sub> O	20	
Solutions B		
FeCl <sub>3</sub> ·6H <sub>2</sub> O	50	10 ml
Solutions C		
Na <sub>2</sub> MoO <sub>4</sub> ·2H <sub>2</sub> O	25	10 ml
Solutions D		
Na <sub>2</sub> EDTA·2H <sub>2</sub> O	50	100 ml
*Quantity used should be dissolved in 800 ml of dH <sub>2</sub> O and kept in an autoclave at 120 °C for 30 minutes and then cooled.		
<i>Vitamin solutions</i>		
Biotin (vitamin H)	0,1	10 ml
Cyanocobalamin (vitamin B12)	0,1	10 ml
Thiamine (vitamin B1)	0,01	10 ml
*A stock vitamin solution is prepared by adding the used amounts to a container containing 1 liter of dH <sub>2</sub> O.		

Using the SOIF brand microscope, the microalgin grown in bottles is counted from the first planting to the last harvest using the Fuchs-Rosen-

thal thoma slide, and the number of cells is determined using a 1 ml “hemocytometer” (Figure 3, Fuentes, 2022). A growth diagram was made from the first planting of the chlorella culture produced to the time of harvest (Figure 4).



Figure 3. Counting cells with a hemocytometer (Maria Fuentes, 2022)

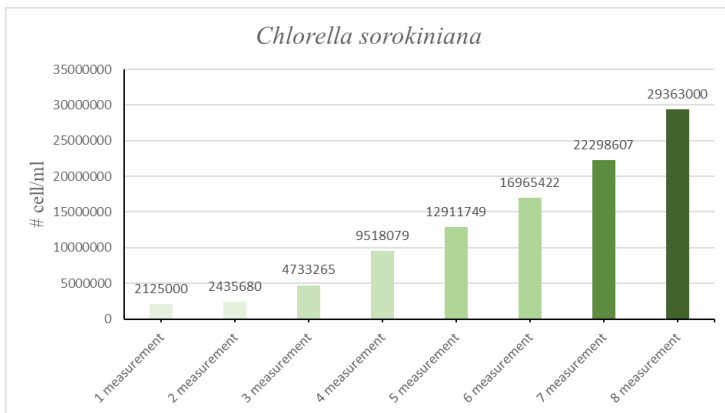

Figure 4. *Chlorella sorokiniana* cell count (# cell/ml)

After 1 bottle filtration was performed on the patient, an infrared lamp was used in the dryer to dehydrate the age culture for up to 24 hours. The remaining 2 chlorella cultures will be kept for the study and cell counts will continue until the end of the study.

### Statistical analysis

Statistical analyses were performed using IBM SPSS Statistics 22.0 software package. Data conforming to parametric testing standards were analyzed using one-way ANOVA followed by Tukey post hoc test where “\*” indicate significant differences among groups.

## Results

### Length and width

Body length was determined by a total of nine measurements every three days. The summarized morphological data are presented in Tables 2-3 and 4. In our study, the Daphnia group fed with liquid microalgae diet grew better in terms of height growth than the other groups at the end of the experiment ( $p<0.05$ ) (Table 2). The experiment was continued for 25 days and after the 5th measurement, a more significant increase was obtained in the daphnia group fed with the commercial diet supplemented with liquid microalgae compared to the other groups.

Table 2. Comparison of length of feed groups by measurement

Measurements	Day	Feed Groups	N	$\bar{X} \pm S$
1	1	POWDER FEED (1)	45	1.716±0.085
		POWDER FEED WITH DRY MICROALGAE (2)		1.960±0.158
		POWDER FEED WITH LIQUID MICROALGAE (3)		1.907±0.127
2	4	POWDER FEED	45	2.046±0.629
		POWDER FEED WITH DRY MICROALGAE		2.092±0.449
		POWDER FEED WITH LIQUID MICROALGAE		2.327±0.469
3	7	POWDER FEED	45	2.400±0.326
		POWDER FEED WITH DRY MICROALGAE		2.410±0.395
		POWDER FEED WITH LIQUID MICROALGAE		2.375±0.420
4	10	POWDER FEED	45	2.542±0.200
		POWDER FEED WITH DRY MICROALGAE		2.444±0.150
		POWDER FEED WITH LIQUID MICROALGAE		2.503±0.195
5	13	POWDER FEED	45	2.580±0.265
		POWDER FEED WITH DRY MICROALGAE		2.560±0.163
		POWDER FEED WITH LIQUID MICROALGAE		2.710±0.134
6	16	POWDER FEED	45	2.635±0.147
		POWDER FEED WITH DRY MICROALGAE		2.729±0.164
		POWDER FEED WITH LIQUID MICROALGAE		2.872±0.137

7	19	POWDER FEED	45	2.785±0.229
		POWDER FEED WITH DRY MICROALGAE		2.729±0.164
		POWDER FEED WITH LIQUID MICROALGAE		3.126±0.211
8	22	POWDER FEED	45	2.840±0.212
		POWDER FEED WITH DRY MICROALGAE		2.814±0.117
		POWDER FEED WITH LIQUID MICROALGAE		3.145±0.169
9	25	POWDER FEED	45	2.852±0.250
		POWDER FEED WITH DRY MICROALGAE		2.937±1.112
		POWDER FEED WITH LIQUID MICROALGAE		3.302±0.188

In the highest creature growth data, more growth was obtained in the liquid microalgae+commercial feed group than in the other groups ( $p<0.05$ ). However, it was observed that the growth in terms of breadth is higher especially in the daphnia, which are full of eggs, and the organism that lays its eggs varies in relation to the measured value.

*Table 3. Comparison of width of feed groups by measurement*

Measurements	Day	Feed Groups	N	$\bar{X} \pm S_x$
1	1	POWDER FEED	45	1.182±0.085
		POWDER FEED WITH DRY MICROALGAE		1.380±0.174
		POWDER FEED WITH LIQUID MICROALGAE		1.363±0.112
2	4	POWDER FEED	45	1.386±0.456
		POWDER FEED WITH DRY MICROALGAE		1.462±0.384
		POWDER FEED WITH LIQUID MICROALGAE		1.554±0.354
3	7	POWDER FEED	45	1.642±0.232
		POWDER FEED WITH DRY MICROALGAE		1.705±0.303
		POWDER FEED WITH LIQUID MICROALGAE		1.703±0.336
4	10	POWDER FEED	45	1.710±0.170
		POWDER FEED WITH DRY MICROALGAE		1.715±0.124
		POWDER FEED WITH LIQUID MICROALGAE		1.862±0.146

5	13	POWDER FEED	45	1.798±0.183
		POWDER FEED WITH DRY MICROALGAE		1.776±0.110
		POWDER FEED WITH LIQUID MICROALGAE		1.862±0.121
6	16	POWDER FEED	45	1.798±0.103
		POWDER FEED WITH DRY MICROALGAE		1.776±0.097
		POWDER FEED WITH LIQUID MICROALGAE		2.036±0.121
7	19	POWDER FEED	45	1.932±0.203
		POWDER FEED WITH DRY MICROALGAE		1.909±0.977
		POWDER FEED WITH LIQUID MICROALGAE		2.231±0.127
8	22	POWDER FEED	45	1.965±0.147
		POWDER FEED WITH DRY MICROALGAE		1.904±0.089
		POWDER FEED WITH LIQUID MICROALGAE		2.256±0.159
9	25	POWDER FEED	45	2.034±0.266
		POWDER FEED WITH DRY MICROALGAE		1.977±0.091
		POWDER FEED WITH LIQUID MICROALGAE		2.144±0.263

The study found that there was a significant difference in the height and width of *D. magna* between the feed types used ( $p < 0.05$ ).

Table 4. Indicates the differences between feeds (Length and width)

(I) Feed	(J) Feed	Mean Difference (I-J)	Std. Error	Sig.	95% Confidence Interval	
					Lower Bound	Upper Bound
POWDER FEED(1)	2	-.0310	.02154	.323	-.0821	.0200
	3*	-.2080*	.02154	.000	-.2590	-.1569
POWDER FEED+DRY M.(2)	1	.0310	.02154	.323	-.0200	.0821
	3*	-.1769*	.02154	.000	-.2280	-.1258
POWDER FEED+LIQUID M.(3)	1*	.2080*	.02154	.000	.1569	.2590
	2*	.1769*	.02154	.000	.1258	.2280

$P < 0.05$ ; p:ANOVA; \*\*, indicate significant differences among groups by Tukey test

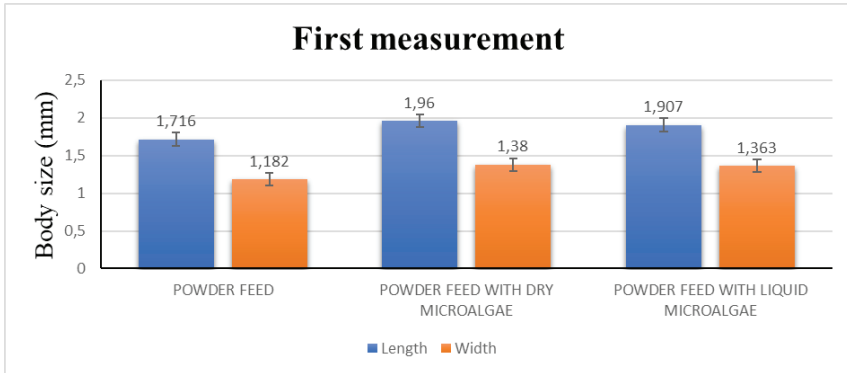

Figure 5. Length and width measurements for the first period in *Daphnia magna*

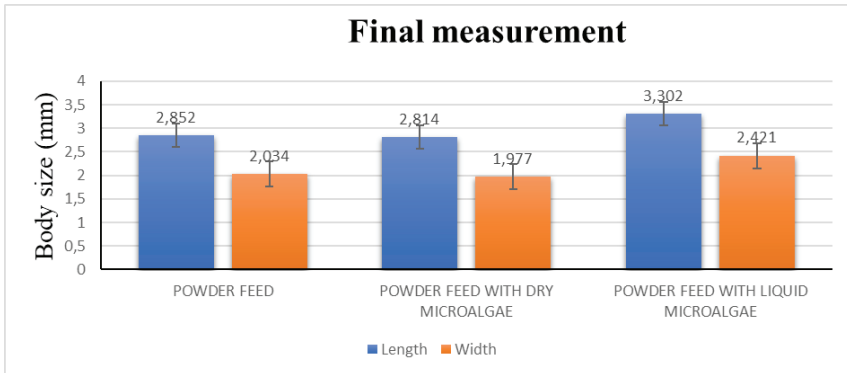

Figure 6. Length and width measurements for the last period in *Daphnia magna*

## Eggs

According to the fourth measurement results of *Daphnia magna* fed with different types of feed, a significant increase was observed when liquid microalgae was used compared to other types of feed (Figure 7). There was no significant difference between the other two feeding groups. Considering the average egg numbers throughout the experiment, it was found that there was a statistically significant difference between liquid microalgae+commercial feed and other feed forms ( $p < 0.05$ ).

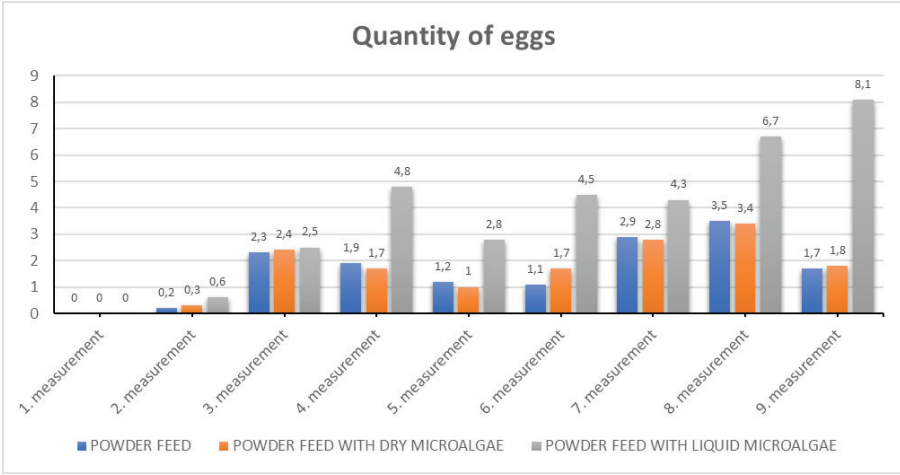

Figure 7. Number of eggs by measurement

Table 5. Indicates the differences between feeds (Eggs)

(I) Feed	(J) Feed	Mean Difference (I-J)	Std. Error	Sig.	95% Confidence Interval	
					Lower Bound	Upper Bound
POWDER	2*	-.1062	.12518	.674	-.4029	.1906
FEED(1)	3	-2.1679*	.12518	.000	-2.4646	-1.8712
POWDER	1	.1062	.12518	.674	-.1906	.4029
FEED+DRY	3*	-2.0617*	.12518	.000	-2.3585	-1.7650
M.(2)						
POWDER	1*	2.1679*	.12518	.000	1.8712	2.4646
FEED+LIQUID	2*	2.0617*	.12518	.000	1.7650	2.3585
M.(3)						

P<0.05; p:ANOVA; \*\*, indicate significant differences among groups by Tukey test

### Offspirings

No significant number of offspring was observed during the first four measurement periods. However, after the fifth measurement period, there was a significant difference between the groups, and the use of liquid microalgae showed a significant difference compared to other forms of feed (Figure 8).

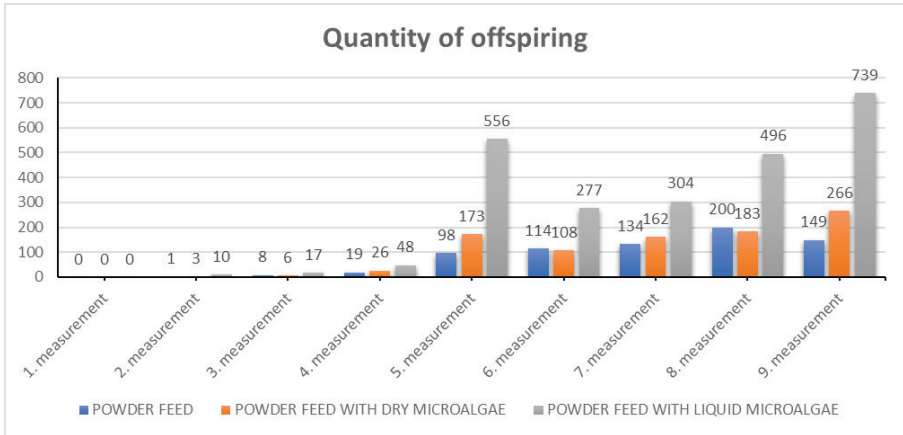

Figure 8. Number of offsprings by measurement

At the end of the experiment, the highest population density was observed when commercial feed+liquid microalgae mixture was used, and the population density obtained after 25 days reached 830.6 individuals per liter. The lowest population density was achieved when commercial feed was used, and 256 individuals per liter were obtained (Figure 9).

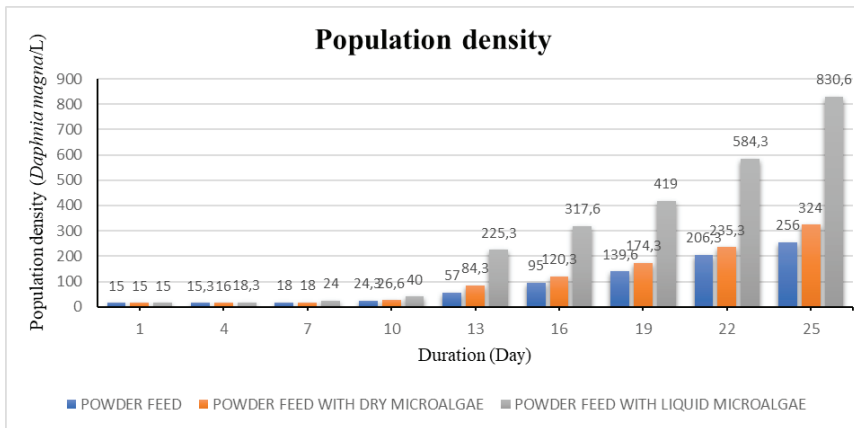

Figure 9. Population density of *D. magna* throughout the study

When evaluating the images obtained at the beginning and at the end of the experiment, it was found that the use of liquid microalgae resulted in greater growth, a higher number of eggs and a higher number of offsprings compared to other forms of feed.

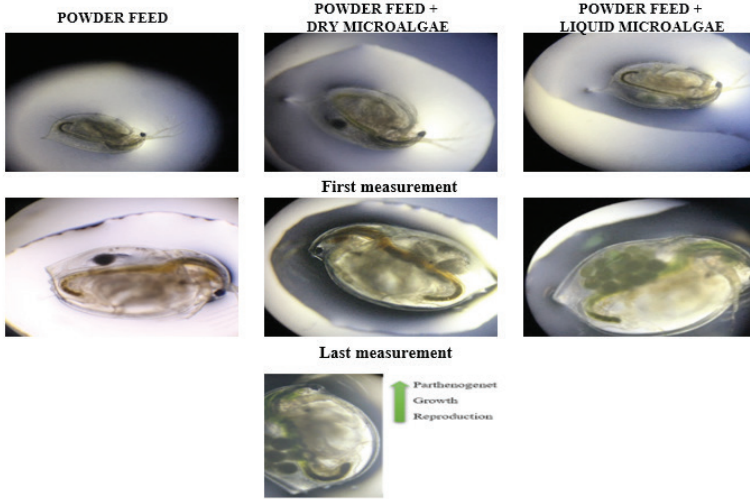

Figure 9. Last images in the study

#### Discussion

In this study, no mortality was observed in *D. magna* on any of the diets used. A diet was prepared combining solid and liquid forms of microalgal cultures with commercial feed of *Daphnia magna* cultures produced under laboratory conditions. The use of commercial feed+liquid microalgae in different diets of *Daphnia magna* reached a population density of 317 individuals/L on day 16. At the end of the experiment, the lowest population density was 90 individuals/L using commercial feed. Thus, a mixed diet was shown to be more effective for *D. magna* than a single diet. Similarly, Khan vd. (2020) reported that the mixed diet in their study reached 207.2 individuals/L after day 15. Similarly, Jorge vd. (2016) reported that the combined diet was better than the single diet in feeding *D. magna* under laboratory conditions, and it was shown that the highest population density occurred in the mixed diet. Thus, it was considered that *D. magna* showed better growth and reproduction when fed with a mixed diet than with a single diet. Liquid microalgae+commercial feed mixture increased *D. magna* in terms of width and length as well as number of eggs compared to other feeding methods. In a study using live microalgae species, Czczuga vd. (2003) fed *D. hyaline*, *D. magna*, and *Simocephalus vetulus* four different microalgae species, resulting in increases in body length and number of eggs. Similarly, Munirasu vd. (2016) in their study showed maximum growth and increase in population of *Chlorella vulgaris* species at 4% concentration compared to baker's yeast. In our study, it was found that the use of liquid microalgae resulted in the maximum growth and number of offspring. Nicolaia vd. (2019) observed that *C. sorokiniana* microalgae had the highest  $\omega 3$  PUFA content (> 3% of dry weight) and

showed a high degree of in vitro digestibility with predominant C18:3 $\omega$ 3 content. Thus, in our study, when the in vivo digestibility properties were evaluated, the solid and liquid form of chlorella, which had a high content of protein, vitamin C,  $\beta$ -carotene, vitamin B<sub>1</sub>, B<sub>2</sub>, B<sub>6</sub>, and B<sub>12</sub>, showed higher bioavailability than the other feeds and the solid and liquid form per se. When evaluating the form, it was found that the liquid form is more effective. At the same time, it was found that the microalgae used did not show toxic effects.

### **Conclusion**

In our study, there were no negative effects when commercial feed was used in combination with microalgae in different types of feeding of *D. magna*. However, it was observed that the use of commercial feed with microalgae resulted in a significant increase in growth, egg and brood numbers in *D. magna*. To this end, the effect of commercial feed combined with microalgae cultures on this creature was studied to provide information to producers.

### **Declaration of Competing Interest**

The authors declare that they have no conflict of interest.

### **Acknowledgment**

The authors sincerely acknowledge the Fisheries and Diseases Laboratory of the Faculty of Veterinary Medicine for their support and cooperation in the study.

## References

- Czeczuga, B., Kozłowska, M., & Kiziewicz, B. (2003). Effect of various types of phytoplankton on fertility, egg size and duration of postembryonic growth of a few plankton representatives of cladocera (crustacea). *Polish Journal of Environmental Studies*, 12(5), 545–555
- Djalil, M., Koniyo, Y., & Mulis (2020). Increasing population of *Daphnia magna* natural feed using the probiotic effective microorganisms-4 (EM4). *Jurnal Ilmiah Perikanan dan Kelautan*, 8(3), 45-50.
- Fouzi, M., N., M., Surakshima, H., A., B., & Withanage, P., M. (2021). Influence of fish meal, yeast and maize on the growth and survival of freshwater zooplankton *Daphnia magna*. *Sri Lankan Journal of Technology*, 46(52).
- Fuentes, M. (2022, December 12). Hemocytometer. Retrieved from <https://www.hemocytometer.org/hemocytometer-app/>
- Herliwati, H., Rahman, M., Hidayet, A., S. & Sumantri, I. (2021). Effect of poultry excreta on water quality and *Daphnia Magna* production in chlorella powder medium. *Journal of Hunan University (Natural Sciences)*, 48(8), 1-6.
- Jorge, C., M., Antonio, O., C., J., German, C., M., Irina, C., C., Carmen, M., D., M., D., & Daniel, B., C. (2016). Laboratory production of *Daphnia magna* (Straus 1820) fed with microalgae and active dry yeast. *Journal of Entomology and Zoology Studies*, 4(2), 548-553.
- Kato, Y., & Watanabe, H. (2022). The mechanism for establishing the binary sex with environmental signals in the crustacean *Daphnia magna*. *Spectrum of Sex*, 203–219. DOI: 10.1007/978-981-19-5359-0\_12
- Khan M. A., Hasan, MD. M., Sumon, K. A., & Rashid, H. (2020). Culture of freshwater zooplankton *Daphnia magna* fed with different feed combination. *Bangladesh Journal of Fisheries*, 32(1), 55-59.
- Kwak, J., H., Baek, S., H., Woo, Y., Han, J., K., Kim, B., G., Kim, A., Y., & Lee J., H. (2012). Beneficial immunostimulatory effect of short-term Chlorella supplementation: enhancement of natural killer cell activity and early inflammatory response (Randomized, double-blinded, placebo-controlled trial) *Nutrition Journal*, 11, 53. doi: 10.1186/1475-2891-11-53.
- McCarty, M., F., Barroso-Aranda, J., & Contreras, F. (2009). Genistein and phycocyanobilin may prevent hepatic fibrosis by suppressing proliferation and activation of hepatic stellate cells. *Medical Hypotheses*, 72, 330-332.
- Munirasu, S., uthayakumar, U., Arunkumar, A., & Ramasubramanian, V. (2016). The effect of different feeds such as *Chlorella vulgaris*, *Azolla pinnata* and yeast on the population growth of *Daphnia magna* commonly found in freshwater systems. *International Journal of Fisheries and Aquatic Studies*, 4(6), 05-10.
- Nicolaia, A., Zittelli, G., C., Rodolfi, L., Biondi, N., & Tredici, M., R. (2019). Microalgae of interest as food source: Biochemical composition and digestibi-

- lity. *Algal research*, 42, 101617. <https://doi.org/10.1016/j.algal.2019.101617>
- Ntanios, F., Y., & Duchateau, S., M., J., E., G. (2002). A healthy diet rich in carotenoids is effective in maintaining normal blood carotenoid levels during the daily use of plant sterol-enriched spreads, *International Journal for Vitamin and Nutrition Research*, 72, 32-39. doi: 10.1024/0300-9831.72.1.32.
- Ocampo, L.,E., Botero, M.,C., & Restrepo, L.,F. (2010). Evaluación del crecimiento de un cultivo de *Daphnia magna* alimentado con *Saccharomyces cerevisiae* y un enriquecimiento con avena soya. *Revista Colombiana de Ciencias Pecuarias*, 23,78-85.
- Panahi, Y., Derviş, B., Jowzi, N., Beiraghdar, F., & Sahebkar, A. (2016). *Chlorella vulgaris*: A Multifunctional Dietary Supplement with Diverse Medicinal Properties, *Current Pharmaceutical Design*, 22(2),164-173. doi: 10.2174/1381612822666151112145226.
- Panahi, Y., Pishgoo, B., Jalalian, H., R., Mohammadi, E., Taghipour, H., R., Sahebkar, A., & Abolhasani, E. (2012). Investigation of the effects of *Chlorella vulgaris* as an adjunctive therapy for dyslipidemia. *Results of a randomised open-label clinical trial*, 69(1),13-19. <https://doi.org/10.1111/j.1747-0080.2011.01569.x>
- Safi, C., Zebib, B., Merah, O., Pontalier, P., Y., & Vaca-Garcia, C. (2014). Morphology, composition, production, processing and applications of *Chlorella vulgaris*. *Renewable and Sustainable Energy Reviews*, 35,265-278
- Setyawan, S., T., Cahyoko, Y., & Sari, L., A. (2022). Providing feed from a mixed of chicken broth and chicken manure with different dosages on nutritional content *Daphnia magna*. IOP Publishing, IOP Conf. Series: *Earth and Environmental Science*, 1036, 012105. doi:10.1088/1755-1315/1036/1/012105
- Ursu, A., V., Marcati, A., Sayd, T., Sante-Lhoutellier, V., Djelveh, G., & Michaud, P. (2014). Extraction, fractionation and functional properties of proteins from the microalgae *Chlorella vulgaris*. *Bioresource Technology*, 157,134-139
- Van Krimpen, M., M., Bikker, P., Van de Meer, I., M., Van de Peet-Schwering, C., M., C., & Vereijken, J., M. (2013). Cultivation, processing and nutritional aspects for pigs and poultry of European protein sources as alternatives for imported soybean products. *Wageningen UR Livestock Research - partner in livestock innovations*, 662.
- Watanabe, F. (2007). Vitamin B12 sources and bioavailability. *Experimental Biology and Medicine*, 232,1266-1274
- Yaakob, Z., Ali, E., Zainal, A., Mohamad, M., & Takriff, M. S. (2014). An overview: biomolecules from microalgae for animal feed and aquaculture. *Journal of Biological Research-Thessaloniki*, 21(1), 1-10.





## **CHAPTER 2**

### **ZOOPLANKTON OF A FRESHWATER BODY (ELAZIG CITY SAMPLE-TURKEY)**

*Hilal BULUT<sup>1</sup>*

---

<sup>1</sup> Doç. Dr., Fırat Üniversitesi, ORCID: 0000-0002-0332-8613, hhaykir@firat.edu.tr

## INTRODUCTION

In fresh water ecosystems, zooplankton communities have a role in transport the movement of matter and energy from primary producers to higher-level consumers (Wetzel, 2001). Zooplankton that provides energy transfer from primary producers, such as phytoplankton, of the food chain to consumer levels. (Al et al., 2018; Howick, 1984). Zooplankton feeding on phytoplankton, other zooplankton species, microorganism bacteria, detritus is an important component of the food chain in aquatic ecosystems (Moss, 1988; Lumpert and Summer, 1997). Zooplankton plays an important role in controlling the phytoplankton population in the ecosystem, as they feed heavily on phytoplankton (Guy, 1992; Trivedi et al., 2003). They take part in the trophic nutrition level of secondary production in aquatic habitats (Vincent et al., 2012; Arruda et al., 2017).

These organisms have a key role in the secondary production level in the flow of matter and energy between unicellular vegetative organisms and carnivorous organisms, especially fish. (Vincent et al., 2012; Arruda et al., 2017). Secondary production is directly or indirectly related to zooplankton. They are involved in the energy cycle and recycling of nutrients. Zooplankton provides the main energy transfer between phytoplankton and fish (Howick, 1984:65). However, streams create difficult conditions for the development of these organisms. Continuous rapid water flow significantly reduces zooplankton, both in number and biomass. The abundance and diversity of zooplankton in lotic habitats vary depending on the physical, chemical and biological characteristics of these environments.

While almost all fish feed on zooplankton during their larval stages, some of them eat zooplankton all their lives. Zooplanktonic organisms constitute the main food source of fish in freshwater sources and they constitute the main food of many pelagic fed fish species and young periods of demersal fish (Kolisko, 1974; Wetzel, 1975).

Aquatic macrophyte status and its geographical structure also affect these lotic habitats (Sampaio et al. 2002). Zooplankton have been used to monitor aquatic ecosystems and water quality as a bioindicator. The distribution of zooplankton affect the climate change, habitat type, physicochemical changes (Ahmad et al., 2011; Cotteni et al., 2001). Zooplankton are indicators that play an important role in aquatic systems and climate change (Molinero et al., 2005). Some degree of success or failure of fishing depends on plankton, especially zooplankton. Fish concentrations are high in areas with high zooplankton production (Xuelu et al.,2011:602).

Environmental factors such as water temperature significantly affect the distribution of zooplankton. Some species have various tolerances to temperature changes, but sensitive species are affected and being elimi-

nated (Andrulewicz, 2008; Tunowski, 2009). Zooplankton were affected by small changes that may occur in their environment. They quickly adapt to these changes. Therefore they are indicators of water quality and pollution levels (Gannon and Stemberger, 1978). Many studies have shown that zooplankton respond quickly to many environmental stressors such as anthropogenic activity, hydrological changes and water pollution caused by climate changes (Duggan, et al., 2001; Pawlowski et al., 2016).

Zooplankton includes various taxa, most of them microscopic, such as protists, cladocerans, copepods, rotifers (Vargas et al., 2015). Rotifera, Cladocera and Copepoda are the largest groups of zooplankton in freshwater environment, which are the main links of the food chain in the aquatic environment. Species diversity and abundance in unit volume provide information about the biological characteristics of reservoirs, streams and ponds. The density of zooplankton is important in any body of water. because they are important food sources for aquatic vertebrates and fish. Also, fish feed on zooplankton at some stage of their life (Ochang et al., 2005).

The number and distribution of zooplankton species that are dominant in any water body provide information about the water quality parameters of that habitat (Jakhar, 2013). The relationship between various environmental features can affect both seasonal and spatial growth or mortality of zooplankton (Khanna et al., 2009). Zooplankton have become bioindicators of aquatic habitat due to their high sensitivity to changes in the environment compared to other aquatic fauna. The presence and abundance of different zooplankton communities in aquatic systems play significant role in the assessment of ecosystem health, as they affect different biotic components (Abowei and Sikoki, 2005). Dirican et al 2009 explained that rotifera species such as *Brachionus* and *Keratella* are more widespread in eutrophic waters.

Some researchers have confirmed the presence of species such as *Filinia longiseta*, *Brachionus forficula*, *Brachionus angularis*, some ostracods and cladocera species such as *Bosmina*, *Moina* and *Macrothrix* indicate areas of high organic matter accumulation and organic pollution, Rao and Durve (1989) and Padmanabha and Belaghi (2008).

To date, many studies have been conducted to examine the distribution of zooplankton in the inland waters of our country. Although there are studies on zooplankton in inland waters, especially dam lakes, lakes and ponds in Turkey, studies on rivers have remained limited. Some researchers have conducted studies on rivers and streams. These; Ozdemir and Sen (1994), Haringet Stream; Saler et al (2000), Fırat River; Saler and Sen (2001), Zıkkım Stream; Ipek and Saler (2008), Seli Stream; Saler (2011), Munzur River; Saler and Haykır (2011) Pulumur Stream; Ipek and Saler (2012), Gorgusan and Geban Stream; Ipek and Saler (2013),

Ohi Stream; Bulut and Saler (2014), Murat River; Saler and Ipek Alış (2016); Tohma Stream; Saler et al., 2018, Hosruk Stream; Bulut and Saler, (2019) Euphrates River; Saler (2022), Sevsak Stream.

## MATERIAL AND METHOD

### Description of Research Area

The Buyuk Stream is 5.225 meters long. Buyuk stream joins the Yukarı Stream and Eskikoy then Altinkusak Streams and pours into the Euphrates River (Kara, T., 2008). Sampling stations in Buyuk Stream is given fig 1.

Zooplankton samples were taken horizontally with Hydro Bios standard plankton mesh with 55 µm mesh size and stored in 4% formalin solution in 250 ml jars. Samples were taken from stagnant or slow-running, vegetation-rich areas of the stream basin. Before examination under microscope samples was mixed then poured to a zooplankton counting chamber and then identified under a binocular microscope (Nikon). Sampling was made seasonally between March 2021/ Feb 2022 from the 2 stations that best characterize the stream. Relevant literatures as Dussart (1969), Flössner (1972), Koste (1978a, b), Dumont and De Ridder (1987), were benefited for identify the species.

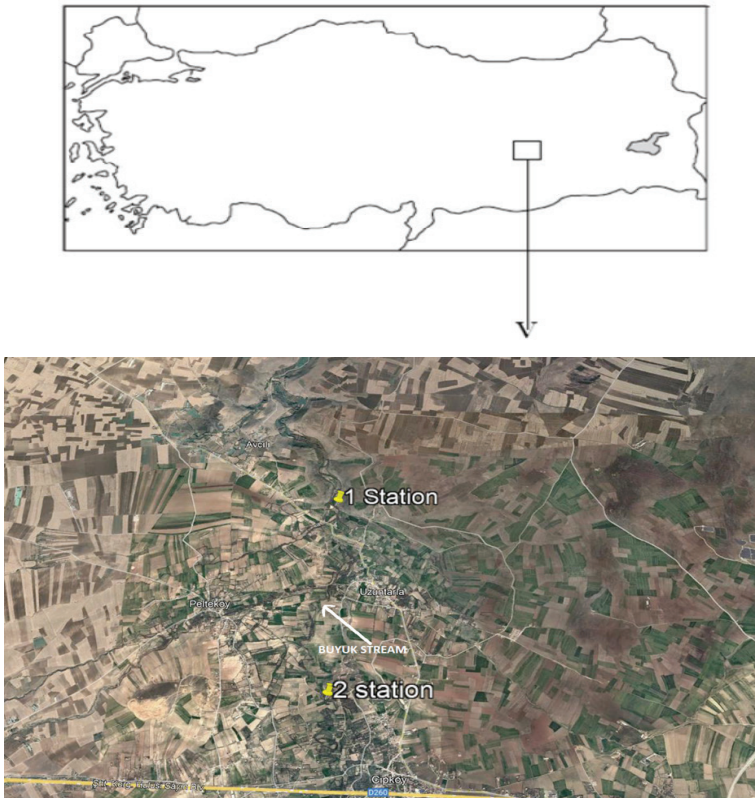

Figure 1. The sampling stations of Buyuk stream (Pelte)

## RESULTS

During the research, a total of 21 species were recorded, including 14 from Rotifera, 4 from Cladocera, and 3 from Copepoda. Distribution of zooplankton according to seasons is given in Table 1. Zooplankton species identified in sampling area were as follow;

### **Rotifera**

Familia: Brachionidae Ehrenberg, 1838

*Brachionus angularis* Gosse, 1851

*Brachionus rubens* Ehrenberg, 1838

*Kellicottia longispina* (Kellicott 1879)

*Keratella cochlearis* (Gosse, 1851)

*Notholca acuminata* (Ehrenberg, 1832)

**Familia: Lecanidae Remane, 1933**

*Lecane luna* (Müller, 1776)

*Lecane nana* (Murray, 1913)

*Lecane stenroosi* (Meissner, 1908)

**Familia: Proalidae Harring & Myers, 1924**

*Proales decipiens* (Ehrenberg, 1832)

**Familia: Notommatidae Hudson & Gosse, 1886**

*Cephalodella gibba* (Ehrenberg, 1830)

**Familia: Trichocercidae Harring, 1913**

*Trichocerca capucina* Wierzejski & Zacharias, 1893

*Trichocerca elongata* (Gosse, 1886)

**Familia: Gastropodidae Harring, 1913**

*Ascomorpha saltans* Bartsch, 1870

**Familia: Conochilidae Harring, 1913**

*Conochilus dossiarius* Hudson, 1885

### **Cladocera**

**Familia: Sididae Baird, 1850**

*Sida crystallina* (Müller, 1776)

**Familia: Daphniidae Sars, 1865**

*Daphnia cucullata* Sars, 1862

*Daphnia longispina* (Müller, 1776)

**Familia: Bosminidae Baird, 1845**

*Bosmina longirostris* (Müller, 1785)

**Copepoda**

**Familia: Cyclopoidae G.O.Sars, 1913**

*Acanthocyclops robustus* (Sars,1863)

*Cyclops vicinus* Uljanin, 1875

*Acanhopdiaptomus denticornis* (Wierzejski1887)

Table 1. Seasonal Distribution of Zooplankton

Seasons	Spring		Summer		Autumun		Winter	
	1	2	1	2	1	2	1	2
<b>Rotifera</b>								
<b>Brachionidae</b>								
<i>Brachionus angularis</i>	+				+			
<i>Brachionus rubens</i>	+	+						
<i>Kellicottia longispina</i>			+					
<i>Keratella cochlearis</i>	+		+			+	+	
<i>Notholca acuminata</i>			+		+	+	+	
<b>Lecanidae</b>								
<i>Lecane luna</i>	+			+		+	+	+
<i>Lecane nana</i>			+		+		+	
<i>Lecane stenroosi</i>	+							
<b>Proalidae</b>								
<i>Proales decipiens</i>					+			

<b>Notommatidae</b>								
<i>Cephalodella gibba</i>	+	+	+					
<b>Trichocercidae</b>								
<i>Trichocerca capucina</i>	+	+						
<i>Trichocerca elongata</i>	+	+						
<b>Gastropodidae</b>								
<i>Ascomorpha saltans</i>					+	+		
<b>Conochilidae</b>								
<i>Conochilus dossiarius</i>	+			+	+			
<b>Cladocera</b>								
<b>Sididae</b>								
<i>Sida crystallina</i>			+					
<b>Daphnidae</b>								
<i>Daphnia cucullata</i>		+	+	+	+			
<i>Daphnia longispina</i>	+	+						
<b>Bosminidae</b>								
<i>Bosmina longirostris</i>		+		+		+		
<b>Copepoda</b>								
<b>Cyclopoidae</b>								
<i>Acanthocyclops robustus</i>		+						
<i>Cyclops vicinus</i>	+			+				

<b>Diaptomidae</b>								
<i>Acanhopdiaptomus denticornis</i>							+	

Considering the seasonal distributions of the identified organisms, *K. cochlearis* (Gosse, 1851), and *L.luna* (Müller, 1776), from Rotifera appeared in all seasons. *N.acuminata* (Ehrenberg, 1832) and *L.nana* (Murray, 1913) were identified in all seasons except spring. *B. longirostris* (Müller, 1785) from Cladocera and Copepoda *C.vicinus* Uljanin, 1875 was observed only in 2 seasons. For all that some species were identified one season. These species from Rotifera *Brachionus rubens* Ehrenberg, 1838, *Kellicottia longispina* (Kellicott 1879), *Lecane stenroosi* (Meissner, 1908), *Proales decipiens* (Ehrenberg, 1832), *Trichocerca capucina* Wierzejski & Zacharias, 1893), *T. elongata* (Gosse, 1886), *Ascomorpha saltans* Bartsch, 1870, from Cladocera *Sida crystallina* (Müller, 1776), *Daphnia longispina* (Müller, 1776), from Copepoda *Acanthocyclops robustus* (Sars,1863), *Acanhopdiaptomus denticornis* (Wierzejski1887) were found only one season. From Rotifera seven families have been identified. Brachionidae was the richest family with 5 species, followed by Lecanidae with 3 species. Daphnidae was the most species rich family with 3 species from Cladocera. Cyclopodidae was the most species rich family with 2 species from Copepoda. When the distribution of zooplankton species according to the groups they represent, it is seen that 67% of the identified species belong to Rotifera, 19% to Cladocera and 14% to Copepoda.

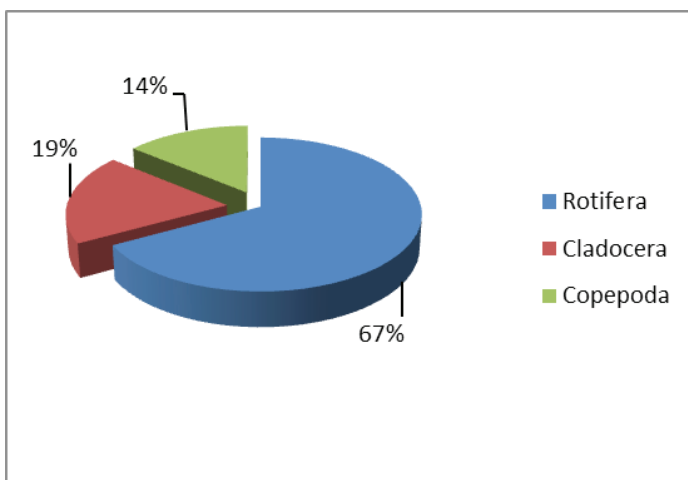

Figure 2. The distribution of zooplankton groups

## DISCUSSION

Zooplankton are important indicators in aquatic habitats. They are important as they determine the trophic status and water quality of aquatic environments (Kolisko, 1974). The rapidly growing rotifers, called true plankton, predominate in lotic habitats. (Hynes, 1970). *K. cochlearis* was observed in all season throughout in this study. In the present study, most of recorded zooplankton species are spread distributed around the world.

There are studies carried out on the Cip dam lake in the same region that was previously made. Akil and Sen (1995) reported that the lake's zooplankton community and reported that organisms belonging to Cladocera and Copepoda were the most important group of zooplankton. Saler and Şen (2000) declared that they found from Rotifera *B.angularis*, *K.longispina*, *L.luna*, *C.gibba* species in Cip dam lake. This species are common in present study.

In lentic habitats, rotifera constitute the dominant group among all zooplankton groups. (Saksena 1987). (Bulut and Saler 2014) reported found totally 25 species from Rotifera, 6 species from Cladocera 2 species from Copepoda in Murat river. It is compatible with our study in terms of rotifera is the dominant species.

In spring, the increasing in temperature of fresh waters, the nutrients also increase. This also increases zooplankton species diversity. Temperature, which is one of the limiting factors, also affects the distribution of zooplanktonic organism. In this study, it is thought that the increase in zooplanktonic organisms is caused by the increase in the amount of food with the warming of the air.

Seasonal distributions of zooplanktonic species in some lotic systems Haringet Kurk, Hosruk Behramaz, streams were showed similarities with this study's findings (Özdemir and Şen, 1994; Saler et al., 2011, Saler et al., 2018; Saler, 2022). Whole of these streams the taxa of zooplankton increased in warm seasons and decreased in cold season.

Smaller-bodied cladocerans, such as *Bosmina*, are generally quite abundant in rivers (Acharya, et al. 2005). In this study, the species that can be observed in all seasons except winter is *B.longirostris*. From Copepoda *Cyclops vicinus* was found for 2 seasons and was the most observed species in present stream. Similar high recorded of copepoda was reported by (Saler et al., 2017; Ipek and Saler, 2012; Bulut and Saler, 2014, Güher and Demir, 2018, Saler, et al., 2018).

As a result of the qualitative evaluation of the samples, The zooplankton of Buyuk Stream consists of Rotifera Cladocera, and Copepoda groups. Rotifers were the dominant zooplanktonic group within these

groups. Rotifera was found as the dominant group in terms of number species. The ratio of species possessed by zooplankton groups was calculated as Rotifera 67%, Cladocera 19% and Copepoda 14%. The zooplankton species found during the research area are important as they are the first record for Buyuk stream.

Phytoplankton and zooplankton in lentic systems have been extensively studied, but studies on plankton community dynamics in lotic systems are scarce (Lair, 2006; Reynolds, 2000). Present study, In today's world, where the importance of fresh water resources has increased biological studies of aquatic ecosystems. It provides information about the current status of our resources. It will shed light on the work planned to be done in the future.

## REFERENCES

- Abowei, J.F.N. and Sikoki, F.D. (2005). *Water Pollution Management and Control*. Doubletrust Publications Company, Nigeria, 236pp.
- Acharya, K. Jack, J.D. and Bucaveckas, P.A.(2005). Dietary Effects On Life History Traits Of Riverine Bosmina. *Freshwater Biology*, 50, 965-975.
- Ahmad, U. Parveen, S. Khan, A. Kabir, H. Mola, H. and Ganai, A.(2011). Zooplankton Population In Relation To Physico-Chemical Factors Of A Sewage Fed Pond Of Aligarh (UP), India. *Biol. Med.*, (3), 336–341
- Andruliewicz, E. Szymelfenig, M. Urba ński, J. Węślowski, J. Węślowski, S. (2008). Baltic Sea It Is Worth Knowing About It. *Noteb. Green Acad.*, (7), 1–113.
- Akıl, A. and Şen, D. (1995). Cip Baraj Gölü'nün (Elazığ-Türkiye) Copepoda ve Cladocera (Crustacea) Türleri Üzerine Taksonomik Bir Çalışma, *Ege Üniversitesi Su Ürünleri Dergisi*, 12(3-4), 195-202.
- Al, M.A., Alam, D., Akhtar, A., Xu, H., Islam, S., Kamal, A.H.M., Uddin, M.M. and Alam, W. (2018). Annual Pattern Of Zooplankton Communities And Their Environmental Response In A Subtropical Maritime Channel System In The Northern Bay Of Bengal, Bangladesh. *Acta Oceanol. Sin.* (37), 65–73.
- Arruda, G.D.A., Diniz, L.P., Almeida, V.L.D.S., Neumann-Leitão, S. and de Melo Junior, M. (2017). Rotifer Community Structure In Fishfarming Systems Associated With A Neotropical Semiarid Reservoir In North-Eastern. *Brazil. Aquac. Res.*, 48, 4910–4922
- Bulut, H. and Saler, S. (2014). Murat Nehri'nin (Elazığ-Palu İlçe Merkezi Sınırları İçindeki Bölümün'de) Zooplanktonu Ve Değişimi, *Türk Tarım Gıda Bilim ve Teknoloji Dergisi*. 2(1), 13-17
- Bulut, H. and Saler, S. (2019). Effect Of Physicochemical Parameters On Zooplankton At A Freshwater Body Of Euphrates Basin (Elazığ-Turkey) . *Cellular and Molecular Biology*, 65(1), 8-13.
- Cottenie, K., Nuytten, N., Michels, E. and De Meester, L. (2001) Zooplankton Community Structure And Environmental Conditions In A Set Of Inter-connected Ponds. *Hydrobiologia*, 442, 339–350
- Dirican, S., Haldun, M. and Suleyman, C. (2009). Some Physicochemical Characteristics And Rotifers Of Camligoze Dam Lake, Susehri, Sivas Turkey. *J. Anim. Vet. Adv.*, 8 (4), 715–719.
- Duggan, I.C., Green, J.D. and Shiel, R.J. (2001). Distribution of rotifers in North Island, New Zealand, and their potential use as bioindicators of lake trophic state. *Rotifera IX*, Springer, Dordrecht, pp. 155-164
- Dumont, H.J. and De Ridder, M. (1987), Rotifers from Turkey. *Hydrobiologia*, 147:65-73.

- Dussart, B. (1969). Les Copepodes des Eaux Continentales d'Europe Occidentale Tale II Cyclopoides et Biologie, N. Boubee et Cie, Paris.
- Flössner, D. (1972). Krebstiere, Crustacea. Kiemen And Blattfüsser Brachiopoda Fischlause, Branchiura, Tierweltdeutschlands. 60. Tiel Veb. Gustav Fischer Verlag, Jena.
- Gannon, J. E. and Stemberger, R. S. (1978). Zooplankton especially crustaceans and rotifers as indicators of water quality. *Transactions of the American Microscopical Society*, 97, 16-35.
- Guher, H and Demir, Y. (2018) Tunca Nehri'nin (Edirne) Microcrustacea: cladocera, Copepoda) Faunası ve Mevsimsel Dağılımı. *Journal of Limnology and Freshwater Fisheries Research*, 4(2), 75-84.
- Guy, D. (1992). *The ecology of the fish pond ecosystem with special reference to Africa*. Pergamon press, 220-230.
- Hynes, H.B.N. (1970). *The Ecology of Running Waters*. Liverpool University Press. Liverpool.
- Howick, G.L. (1984). Zooplankton and benthic microinvertebrates in lake Carl Blackwell. *Proc. Okla. Acad. Sci.*, 64, 63–65.
- Ipek, N. and Saler, S. (2012). Zooplankton Community Structure of Ohi Stream (Elazığ-Turkey), *Journal of Fisheriessciences.com*. 7(1), 83-88 DOI:10.3153/jfsc.com.2013009,
- Ipek, N. and Saler, S. (2013). Zooplankton Community Structure of Ohi Stream (Elazığ-Turkey). *Journal of Fisheriessciences.com*. 7(1), 83-88
- Jakhar P. (2013). Role of phytoplankton and zooplankton as health indicators of aquatic ecosystem: A review. *International Journal of Innovation Research Study*, 2(12), 489–500.
- Kara, T., 2008. Büyük Çay (Pelte, Elazığ) Da Bulunan Chironomidae Larvalarının Taksonomik Yönden İncelenmesi, Yuksek Lisanstezi. Elazığ: Fırat Üniversitesi.
- Khanna, D.R., Bhutiani, R., Gagan, M., Ginh, V., Kumar, D., and Ahraf, J. (2009). A Study Of Zooplankton With Special Reference To The Concentration Of River Ganga At Haridwar. In: *Environ. Conserv. J.* 10 (3), 15–20.
- Kolisko, R. (1974). Plankton rotifers biologyand taxonomy. E.Schweizerbart'sche Verlagsbuchhandlung (Nageleu Obermiller), Stuttgart, Germany
- Lair, N. (2006). Metazoan planktonun düzenleme mekanizmalarının gözden geçirilmesinehir ekosistemlerinde: Biyotaya karşı su habitatu. Nehir Araştırmasıve Uygulama,22, 567–593.
- Molinero, J.C., Ibanez, F., Nival, P., Buecher, I. And Souissi, S. (2005). North Atlantic Climatevariability And Planktonic Communities: the effect of an extreme event (severe drought) in a southern European estuary. *Estuar.Coast.Shelf Sci.* 73, 725-734.

- Moss, B.(1988). Ecology of Freshwater. Wiley–Blackwell, New Jersey, USA.1–352.
- Ochang, S.N., Ayotunde, E.O. and Okey, I.B. (2005). Some Aspects Of The Physicochemical And Biological Properties Of Cross River, An Inland Water Body In South- Eastern Nigeria. *Global J Agricultural Sciences*. 4, 139–148.
- Ozdemir, Y. and Sen, D. (1994). Haringet Çayında Saptanan Zooplankter Organizmalar. *Fırat Üniversitesi Fen ve Mühendislik Bilimleri Dergisi*, 6(2): 136-140
- Padmanabha, B., Belaghi, S.L. (2008). Ostracods As Indicators Of Pollution In Lake Mysore. *J. Environ. Biol.* 29 (3), 415–418.
- Pawlowski, J., Lejzerowicz, F., Apotheloz-Perret-Gentil, L., Visco, J. and Esling, P. (2016). Protist Metabarcoding And Environmental Biomonitoring Time For Change. *Eur. J. Protistol.*, 55, 12-25
- Rao, N.G. and Durve, V.S. (1989). Cultural Eutrophication Of The Lake Rangasagar, Udaipur, Rajasthan. *J. Environ. Biol.*, 10, 127–134.
- Reynolds, C.S (2000). Nehir planktonunun hidroekolojisi: Değişkenlerin rolü Kanal akışında yetenek. *Hidrolojik Süreçler*, 14, 3119–3132.
- Saler (Emiroğlu), S. and Şen, D. (2000). Cıp Baraj Gölü (Elazığ) Rotifera Faunasının Taksonomik Yönden İncelenmesi, *Fırat Üniversitesi Fen ve Mühendislik Bilimleri Dergisi*, 12 (1), 329-339.
- Saler, S. (2011). Zooplankton of Munzur River (Tunceli - Turkey). *Journal of Animal and Veterinary Advances*, 10 (2), 192-194.
- Saler, S. and Haykır, H. (2011). Zooplankton Composition of Pülümür Stream (Tunceli-Turkey). *Journal of Animal and Veterinary Advances*. 10, 1401-1403.
- Saler, S., Aslan, S. and Ipek, N. (2011). Kürk Çayı (Elazığ-Türkiye) Zooplanktonu. *Journal of Fisheries Sciences.com*. 5, 219-225.
- Saler, S. (2018). Zooplankton of Behramaz Stream (Elazığ-Türkiye). *Ecological Life Sciences*, 17(4)
- Saler, S., Yuce, S., Celik, B. and Bulut, H. (2018). Hoşrük Çayı (Elazığ-Türkiye) Zooplanktonu, *Türk Tarım – Gıda Bilim ve Teknoloji Dergisi*, 6 (5), 607-61.
- Saler, S. (2022). Zooplankton Diversity of Sevsak Stream (Elazığ-TURKIYE). *Asian Journal of Fisheries and Aquatic Research*, 18(6), 15-21
- Sampaio, E.V., Rocha, O., Matsumura-Tundisi, T., Tundisi, J.G. (2002). Composition And Abundance Of Zooplankton In The Limnetic Zone Of Seven Reservoirs Of The Paranapanema River, Brazil. *Braz J Biol.* 62, 525-545
- Tunowski, J. (2009). Zooplankton Structure In Heated Lakes With Differing Thermal Regimes And Water Retention. *Fish. Aquat. Life*, 17, 291–303.
- Vargas, C., De, Audic, S. . Henry, N Decelle, J. Mahé F. , Logares R., et al.(2015).

Eukaryotic Plankton Diversity In The Sunlit Ocean Science, 348 (6237)  
p. 1261605

Vincent, K. Mwebaza-Ndawula, L. Makanga, B., Nachuha, S. (2012). Variations In Zooplankton Community Structure And Water Quality Conditions In Three Habitat Types In Northern Lake Victoria. *Lakes Reserv. Res. Manag.* , 17, 83–95.

Wetzel, R. G. (2001). *Limnology: lake and river ecosystems*. New York, USA: Academic Press,

Trivedi, R.K., Guruna, V., Das, B.K. and Rout, S.K. (2003). Variations Of Plankton Population Of Two Hill Streams Of The Darjeeling District, West Bengal. *Enviro and Ecol*, 21, 50-53.

Wetzel, R.G. (1975). *Limnology WB*. Philadelphia: Sauders Company, 743.

Xuelu, G.A.O., Jinming, S. and Xuegang, L. (2011). Zooplankton Spatial And Diurnal Variations In The Changjiang River Estuary Before Operation Of The Three Gorges Dake. *Chin.J.Oceanol.Limnol.* 29 (3), 591-602.



## ***CHAPTER 3***

### **ROLE OF BIO – ACTIVE COMPOUNDS TO PREVENT OXIDATIVE DAMAGE IN MAIZE**

*Seher ÖZKAN<sup>1</sup>, Elif ÖZDEMİR<sup>2</sup>*

<sup>1</sup> Zir. Müh., Selçuk Üniversitesi, Fen Bilimleri Enstitüsü, Konya/  
TÜRKİYE 0000 – 0002 – 1738 – 4202

<sup>2</sup> Dr. Öğr. Üyesi, Selçuk Üniversitesi, Ziraat Fakültesi, Tarla  
Bitkileri Bölümü, Konya/TÜRKİYE 0000 – 0003 – 3153 – 1739

## 1. INTRODUCTION

Secondary metabolites are important components that affect product quality in maize. Phenolics and anthocyanins, which have antioxidant properties, are important in terms of stress management in living organisms. Understanding the effects of herbal antioxidants in the prevention of chronic degenerative diseases, increases the importance of plants in human nutrition day by day. Coloured corn, rich in anthocyanins and antioxidants, has been consumed for many years as a flavouring and colouring agent (Adom & Liu, 2002).

Corn has higher antioxidants and phenolic contents compared to wheat (Nikolic et al., 2019), because of this way of corn, many studies have been conducted to develop new varieties with higher antioxidant capacity in the recent years, so there is a need to analyse the anthocyanin and phenolic components of maize.

Any environmental factor that is not suitable for the survival of living organisms is called 'Stress'. Plants under stress have developed different defence mechanisms to protect themselves from the negative effects of stress factors. One of the defensive responses is the scavenging of reactive oxygen species (ROS). Plants with higher antioxidant content are more resistant to stress, less ROS damage is seen in them. When ROS increase, the chain of harmful reactions that will occur in the plant begins (Kacar, Katkat, & Öztürk, 2009; Sade, Soylu, & Yetim, 2011).

Stress negatively affects the growth and development of the plant, causing physiological and metabolic changes. For example, water stress shortens the height of the plant and narrows the leaf area. It also causes significant losses in dry matter weight (Cakir, 2004). Drought stress delays pollen shedding and silk emergence in maize; silks that come out can dry out with the effect of high temperature and relative humidity. Drought is a phenomenon that has significant negative effects on yield due to all these reasons (Anonymous, 1999). Biotic (disease stress) and abiotic (drought, salinity, high temperature, frost, light and ultraviolet light, flooding, oxidative stress, air pollutants and heavy metal stress) stress factors can cause yield losses between 65% and 82% in the plant production (Kacar et al., 2009). In this part of the review, oxidative stress, which is one of the important stress factors in plants, will be emphasized.

## 2. OXIDATIVE STRESS

Plants are constantly exposed to environmental effects (O'Brien, Daudi, Butt, & Paul Bolwell, 2012), this triggers ROS production and oxidative stress. Reactive oxygen species are structures formed by the conversion of oxygen into compounds containing a more reactive oxygen atom, depend-

ing on cellular and non – cellular reactions (Fig. 1) (Sade et al., 2011).

Reagents can exist as radicals, unpaired electrons, or non – radical forms. Until recently, it was argued that ROS triggers significant cellular damage that causes premature aging and neurodegenerative disorders (Harman, 2002). Harman (2002) reported that since the theory of the effect of free radicals on aging, many studies have been conducted on the effects of ROS and reactive nitrogen species (RNS) on disease progression. The formation of low amounts of ROS has been shown to trigger a variety of cellular signals that allow cell growth.

The organism tries to detoxify free radicals, which are the natural products of physiological activity in living organisms, with an innate balance (oxidant – antioxidant). Disruption of this balance leads to oxidative stress. Reactive oxygen species which are in the oxidant class; occur because of abiotic stress factors such as drought, salinity, and extremely high temperature. Numerous studies have shown that biotic and abiotic stress factors cause an increase in antioxidant enzyme levels (Sade et al., 2011).

Abiotic stress factors disrupt the functioning of the cell, causing regression of plant growth and metabolism. Reactive oxygen species are not only toxic by – products of aerobic metabolism, but also signal molecules involved in various developmental processes in all organisms (Nanda, Andrio, Marino, Pauly, & Dunand, 2010).

Components such as singlet oxygen, hydroxyl radical and hydrogen peroxide damage vital components of the plant cell such as membrane lipids, proteins, enzymes, pigments, and nucleic acids (Sade et al., 2011).

When ROS cannot be detoxified by the antioxidant system, the accumulation of them becomes phyto – toxic, attacking, and damaging proteins, lipids and DNA (Breusegem & Dat, 2006).

Control of ROS signalling requires a large gene network, for example the ROS gene network in *Arabidopsis* consists of approximately 150 genes (Nanda et al., 2010).

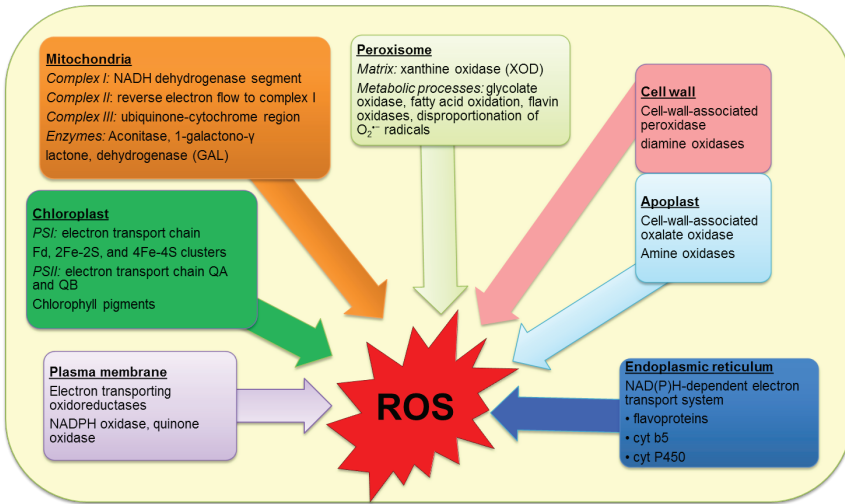

**Figure 1.** Sites of production of reactive oxygen species (ROS) in plants (Anonymous, 2022)

## 2.1. Reactive Oxygen Species

Free radicals in living organisms are molecules that can exist independently by having unpaired electrons in their atomic orbitals. Reagents of molecular oxygen are important free radicals (Fig. 2).

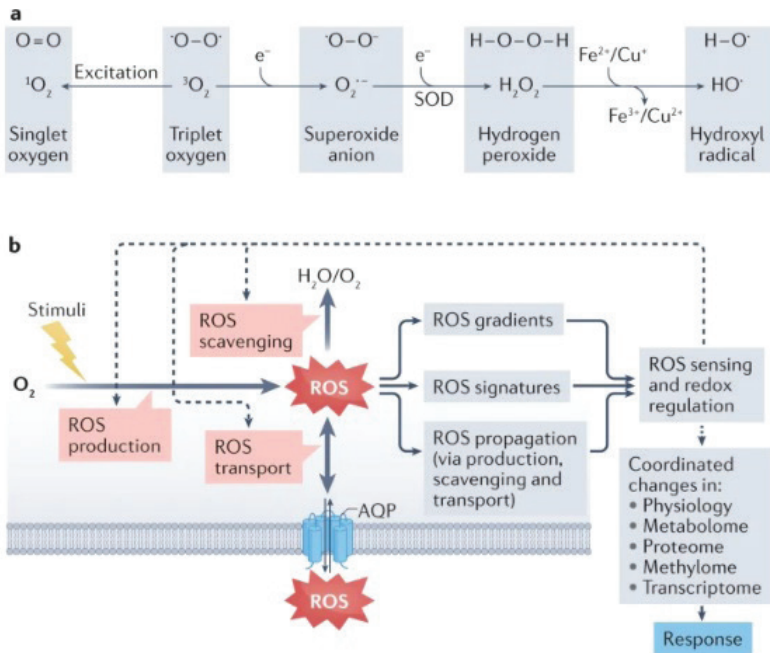

**Figure 2. a.** Formation of reactive oxygen species (ROS) by excitation or reduction of atmospheric oxygen. **b.** Cellular ROS concentrations are regulated by three distinct processes: ROS production, scavenging and transport (Mittler, Zandalinas, Fichman, & Van Breusegem, 2022)

### 2.1.1. Superoxide radical

It is known that the superoxide radical is formed by the binding of an electron to the oxygen molecule, which is necessary for vital events. Although it is known for being a free radical, its reactivity is not high. Its production takes place in mitochondria (Karabulut & Gülay, 2016). The main importance of this radical anion is that it is a source of hydrogen peroxide and a reducer of transition metal ions. Another feature is that it has an oxidizing effect. It is more reactive at low pH. Superoxide is a strong reducing agent and can reduce iron complexes such as cytochrome c and ferric – EDTA (Antmen, 2005; Sade et al., 2011).

Even if small amounts of electron leakage occur in energy conversion events, this causes oxygen to turn into superoxide radicals and cause various diseases (Karabulut & Gülay, 2016).

### 2.1.2. Hydrogen peroxide

Hydrogen peroxide is not a free radical but is important because it damages biological membranes. Another important task of hydrogen per-

oxide is that it is an intracellular signal molecule (Karabulut & Gülay, 2016). Hydrogen peroxide is formed because of the dismutation reaction of the superoxide radical (Antmen, 2005).

Two superoxide molecules take two protons in the dismutation reaction of superoxide, forming hydrogen peroxide and molecular oxygen. This reaction is known as a dismutation reaction as it produces non – radical products, either spontaneously or catalysed by the SOD enzyme. It is known that hydrogen peroxide causes the formation of hydroxyl radical (an oxygen radical) because of “Fenton Reaction” in the presence of Fe or other transition metals, and / or as a result of “Haber-Weiss” reaction in the presence of superoxide radical (Antmen, 2005).

### **2.1.3. Hydroxyl radical**

Hydroxyl radical is formed from hydrogen peroxide because of “Fenton Reaction” and “Haber Weiss” reaction. Hydrogen peroxide reacts with superoxide and is easily broken down to form the most reactive and most damaging hydroxyl radical. This reaction is called the “Haber Weiss” reaction and while the reaction is quite slow in the absence of a catalyst, it is quite fast under the catalysis of Fe (Antmen, 2005).

## **2.2. Effects of ROS**

### **2.2.1. Effects of ROS on DNA and nucleic acids**

Reactive oxygen species, which are formed because of the increase in oxidative stress, attack the double bonds of DNA and initiate chain oxidation reactions by breaking a hydrogen atom. As a result, macromolecules such as DNA are damaged (Özcan, Erdal, Çakırca, & Yönden, 2015). Free radicals can cause mutations in the cell by affecting DNA (Antmen, 2005).

### **2.2.2. Effects of ROS on proteins**

Oxidative stress disrupts the structure of proteins and enzymes in the structure of the cell, leading to the deterioration of the cell structure. They cause two types of deterioration in the protein structure; protein carbonylation and tyrosine nitration are considered irreversible, while cysteine degradations are considered reversible degradations (Özcan et al., 2015).

### **2.2.3. Effects of ROS on carbohydrates**

Carbohydrates are less damaged than lipids and proteins. Reactive oxygen species react with carbohydrate polymers, causing the carbohydrates to break down. Reactive oxygen species can also negatively affect membrane glycoproteins, which can change the surface receptors in spermatozoa (Türk, 2015).

#### 2.2.4. Effects of ROS on lipids

Lipid peroxidation is the process by which ROS take up polyunsaturated fatty acids from the cell membrane. The cell is extremely sensitive to this phenomenon, and because of lipid peroxidation, approximately 60% of the fatty acids are lost and various deteriorations occur in the cell structure (Türk, 2015). Free radicals are molecules containing unpaired electrons. These reactive oxygen and nitrogen species can damage cells by disrupting the cell's DNA, proteins, and other cellular components. Before they can reach the cell, they must cross the plasma membrane. The lipid plasma membrane forms the boundaries of the cell and separates the inside of the cell from the extracellular environment. This membrane plays a critical role in protecting cells by controlling the entrance of free radicals. It also participates in the exchange of cellular nutrients, water, ions, and other molecules. The oxygen atom has a high affinity for lipids. For the oxygen atom to be used in tissues, it must first be dissolved in the lipoproteins in the plasma and in the erythrocyte membrane. In the meantime, lipid peroxidation occurs when the hydroxyl radical binds to the unsaturated fatty acids in the membranes (Büyüksulu & Yiğitbaşı, 2015). The only mechanism that produces malondialdehyde (MDA) in biological systems is lipid peroxidation. Xenobiotics can increase lipid peroxidation by increasing the formation of free radicals or reducing the defence capacity of the cell against peroxidation reactions (Dogan, 2005). Sodium, potassium, magnesium, and phospholipids in cell structure, are necessary for ATP thus the enzyme system also deteriorates with the deterioration of phospholipids. Another hypothesis is that excess  $H_2O_2$  induces G6PD inhibition, which controls glucose flow through NADPH in the cell. This inhibition causes a decrease in the activity of NADPH in the cell and causes the accumulation of oxidized glutathione. This weakens the antioxidant defence system (Türk, 2015).

#### **Lipid peroxidation consists of three steps,**

##### ***Start,***

Lipid peroxidation begins with the oxidizing property of the hydroxyl radical, which cleaves a hydrogen atom from polyunsaturated fatty acids. A lipid radical is formed by the splitting of the hydrogen atom. The radical, which reacts with oxygen and forms lipid peroxy radical because of its high reactivity, reacts with unsaturated fatty acids and removes a hydrogen atom from the system or forms a carbon – centred radical with the addition of double bonds (Antmen, 2005; Dogan, 2005; Sade et al., 2011).

##### ***Progression,***

The lipid peroxy radical cleaves a hydrogen molecule from another

lipid molecule. Thus, lipid hydroperoxide and a second radical are formed. This, in turn, causes a continuum of cell disruption (Antmen, 2005; Dogan, 2005).

*End,*

It occurs because of the reaction of any radical with a protein or a compound capable of catching free radicals, and the final product is formed. The formation of end products is the termination of lipid peroxidation. Reactions between the by – products of lipid peroxidation cause serious damage to membrane proteins (Antmen, 2005; Dogan, 2005).

### **3. IMPORTANCE OF ANTIOXIDANTS AND BIO – ACTIVE COMPOUNDS**

#### **3.1. Antioxidants**

The antioxidant content of foods and the bio – usefulness of antioxidants can vary according to the type of foodstuffs, harvest time, harvest methods, temperature – light of the storage, preservation environment, climate, humidity, food preparation, and even the consumption habits of the person and society (Güleşçi & Aygül, 2016). Oxygen is an essential molecule for living organisms to survive. If the oxygen molecule is incompletely reduced, ROS occurs, which damages cells. If ROS are produced too much for the antioxidant defence system to extinguish in the cells, this event is defined as “Oxidative Stress”. Güleşçi and Aygül (2016) defined oxidative stress as the disruption of the balance between free radicals and the antioxidant defence system, which is their scavenger, in favour of ROS. Antioxidants are components that protect foodstuffs and living organisms that consume these foods against the oxidative damage of free radical molecules such as nitrogen species and ROS. Since the most important source of antioxidants is plant, dietary antioxidants are often called phyto – chemical antioxidants. Natural antioxidant components in foods, they show their antioxidant effects with one or more of reducing agent, free radical scavenger, singlet oxygen scavenger mechanisms. Antioxidants are components that neutralize free radicals in living organisms and prevent cells from being affected by them or enable them to renew themselves (Fig 3.) (Güleşçi & Aygül, 2016).

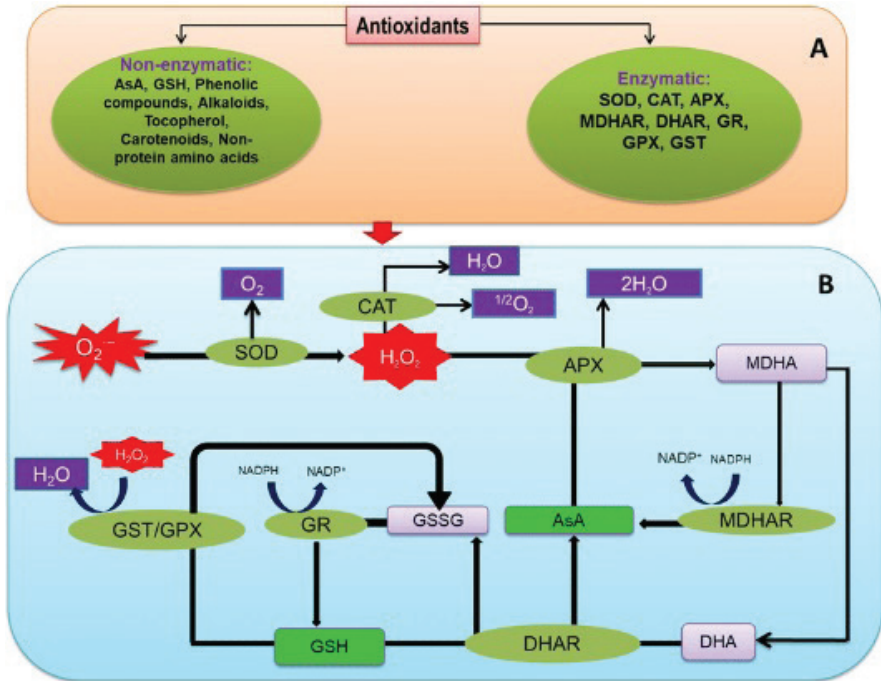

**Figure 3.** Outline of antioxidant defence mechanisms in plants; (A) types of antioxidants and (B) mechanism of antioxidant enzymes and low molecular weight antioxidants to detoxify ROS (Hasanuzzaman et al., 2020)

### 3.2. Phenolics Compounds

Phenolic compounds are substances containing one or more hydroxyl groups, including functional derivatives attached to an aromatic ring. Phenolics are among the most active natural antioxidants, and they exert their antioxidant effects by binding free radicals, forming chelates with metals and inhibiting lipoxygenase enzyme (Güleşçi & Aygül, 2016).

Polyphenols, which are among the phenolic compounds, are antioxidants that can scavenge radicals that break the bonds of lipids and ROS, by binding with bonds like chelates made by metal ions (Güleşçi & Aygül, 2016). Phenolic substances in plant foods; lignans, phenolic acids, stilbenes, and flavonoids.

Phenolic acids and flavonoids are important antioxidants. Phenolic substances as food ingredient; they contribute to enzyme inhibition with their effects on taste and on formation, their participation in colour formation and change, their anti – microbial and anti – oxidative effects. Polyphenolic substances, which are named according to the chemical structure of phenolic compounds, the number of rings they contain and their structural

elements, generally have a phenol ring, as in phenolic acids and alcohols (Petroni, Pilu, & Tonelli, 2014).

### 3.3. Flavonoids

Flavonoids are low molecular weight compounds that are arranged in C6—C3—C6 configuration and contain fifteen carbon atoms. Differences between flavonoids due to the number of hydroxyl groups attached, the degree of unsaturation and the oxidation level of the triple carbon segment (Kolaç, Gürbüz, & Yetiş, 2017). Changes in the C ring, groups flavonoids such as chalcones, flavones, flavonols, catechin and isoflavones (Kolaç et al., 2017). Flavonoids are located in the root of the host plant assist *Rhizobium*, which establishes a symbiotic relationship with legumes such as peas, beans, alfalfa, and soybean. Soil – dwelling *Rhizobium* can sense flavonoids, which induce various cellular responses by the host plant, such as deformation of root hairs, ion fluxes, and root nodule formation. In addition, some flavonoids have inhibitory activity against organisms that cause plant diseases (Galeotti, Barile, Curir, Dolci, & Lanzotti, 2008).

### 3.4. Anthocyanins

Anthocyanin means flower and blue in Latin. The basic building block of more than 500 isolated anthocyanins from plants is “Flavillium Ion”. Anthocyanin gives the colours of many fruits and vegetables ranging from pink to purple, such as blackberries, raspberries, pomegranates, red cabbage, black and red currants, tree strawberries, French beans, plums. Heating and / or fermentation of the fruit allows anthocyanins to pass into the water. Anthocyanins have important roles in defence, pollination, and reproduction as well as antioxidant and protection of plants from UV rays. The colours of the flowers, which attract many insects, especially wasps and birds, come from anthocyanins.

The hydroxyl group on the third carbon atom of 16 different anthocyanidins found in nature; 140 anthocyanins in very different colours, which are formed by the binding of one or two sugars such as glucose, galactose, rannose, xylose and arabinose, have been detected (Kolaç et al., 2017).

## 4. BIO – ACTIVE COMPOUNDS IN MAIZE

### 4.1. Antioxidants in Maize

Antioxidants are components that protect tissues and organs against oxidative damage by free radicals such as ROS. The enzymatic (SOD, CAT, POD and GR) and non – enzymatic (ASC, glutathione,  $\alpha$  tocopherol and carotenoids) antioxidants in corn protect plants from the damage of ROS caused by stress factors (Sade et al., 2011). Natural antioxidant components in corn reduce agents, bind free radicals, and scavenge singlet

oxygen (Güleşçi & Aygül, 2016).

There are many enzymatic and non – enzymatic defence mechanisms that protect cells against oxidative damage. Non – enzymatic ones include glutathione, cysteine, hydroquinones, mannitol, vitamins C and E, flavonoids, some alkaloids, and  $\beta$ -carotene (Sade et al., 2011). The ability of antioxidants to capture free radicals is associated with being proton donors (Haslina & Eva, 2017).

Enzymatic antioxidants collect, neutralize, and remove oxygen intermediates and free radicals. Ascorbate peroxidase and GR are considered antioxidants to detoxify  $H_2O_2$  in chloroplasts and mitochondria. It is CAT and POD, which effectively removes  $H_2O_2$  from the environment, and SOD, which collects superoxide. Catalase and SOD are the most effective antioxidant enzymes. By working together, the two enzymes prevent cellular damage by converting dangerous superoxide and  $H_2O_2$  into water ( $H_2O$ ) and molecular oxygen ( $O_2$ ) (Keser, 2005).

The development of antioxidant systems in plants has been associated with resistance to environmental stress factors. For example, high elimination of Mn – SOD, chloroplastic Cu – SOD, Zn – SOD or Fe – SOD increases the defence against oxidative stress in transgenic tobacco plants (Sade et al., 2011). Žilić, Kocadağlı, Vančetović, and Gökmen (2016) reported that there was no significant difference between the total antioxidant capacity of corn silk in the silking stage and the antioxidant capacity of plants containing high bio – active components. Extracts from corn silk have been shown to have great potential in preventing diseases caused by free radicals. The low cost of corn silk has also increased its use in alternative medicine (Liu et al., 2011).

#### **4.2. Phenolic Compounds in Maize**

Phenolic acids are derivatives of benzoic and cinnamic acids and are commonly found in plants. The total phenolic content of plant extracts was associated with the antioxidant activities of plant tissues; it has been accepted that flavonoids are in the groups of phenolic compounds with high antioxidant properties. Phenolic components are biochemicals that also have an antioxidant effect in corn flour (Şerment & Kahrman, 2021).

#### **4.3. Anthocyanins in Maize**

Anthocyanins are components that provide colour formation in the corn grain and generally give the grain their purple – red colour (Fig. 4) (Şerment & Kahrman, 2021). It is known that the pigments found in maize are anthocyanins, one of the flavonoids, which are secondary metabolites, consisting of about 20 biosynthetic genes, synthesized in a metabolic way. It is also known that flavonoids play an important role in pollination, fer-

tilization, UV protection and protection from oxidative stress in plants (Petroni et al., 2014).



**Figure 4.** Near — isogenic maize lines enriched in specific classes of flavonoids. Maize seeds with high levels of anthocyanins in aleurone (a) or pericarp (c). Maize seeds enriched in hydroxycinnamic acids (b), phlobaphenes (d), flavonols (e) and pelargonidin (f) (Petroni et al., 2014)

## CONSLUSION

As a result, it is seen that the maize contains anthocyanins, one of the phenolic components, in both vegetative organs such as tassels and generative organs such as grain. Anthocyanin sources are components of antioxidant character. The fact that coloured corn is rich in phenolic components, flavonoids and therefore anthocyanins has made it important to search for alternative uses.

## REFERENCES

- Adom, K., & Liu, R. (2002). Antioxidant activity of grains. *Journal of Agricultural and Food Chemistry*, 50(21), 6182-6187.
- Anonymous. (1999). Effects of stress during grain filling in corn. <https://www.agry.purdue.edu/ext/corn/news/timeless/grainfillstress.html>.
- Anonymous. (2022). Extreme temperature responses, oxidative stress and antioxidant defense in plants. <https://www.intechopen.com/chapters/43317>.
- Antmen, E. (2005). *Beta talasamide oksidatif stres*. (Yüksek Lisans). Çukurova Üniversitesi, Adana.
- Breusegem, F., & Dat, F. (2006). Reactive oxygen species in plant cell death. *Physiology*, 141(2), 384-390.
- Büyüksulu, N., & Yiğitbaşı, T. (2015). Reaktif oksijen türleri ve obezitede oksidatif stres. *Clinical and Experimental Health Sciences*, 5(3), 197-203.
- Cakir, R. (2004). Effect of water stress at different development stages on vegetative and reproductive growth of corn. *Field Crops Research*, 89(1), 1-16.
- Dogan, M. (2005). *Physiological and morphological effects of cadmium chloride, sodium chloride and their combinations in Ceratophyllum demersum L.* (pHD). Çukurova Üniversitesi, Adana.
- Galeotti, F., Barile, E., Curir, P., Dolci, M., & Lanzotti, V. (2008). Flavonoids from carnation (*Dianthus caryophyllus*) and their antifungal activity. *Phytochemistry Letters*, 1(1), 44-48.
- Güleşçi, N., & Aygül, İ. (2016). Beslenme yer alan antioksidan ve fenolik madde içerikli çerezler. *Gümüşhane Üniversitesi Sağlık Bilimleri Dergisi*, 5(1), 109-129.
- Harman, D. (2002). Aging: a theory based on free radical and radiation chemistry. *Science of Aging Knowledge Environment*, 2002(37), 298-300.
- Hasanuzzaman, M., Bhuyan, M., Parvin, K., Bhuiyan, T., Anee, T., Nahar, K., . . . Fujita, M. (2020). Regulation of ROS metabolism in plants under environmental stress: A review of recent experimental evidence. *International Journal of Molecular Sciences*, 21(22), 86-95.
- Haslina, H., & Eva, M. (2017). Extract corn silk with variation of solvents on yield, total phenolics, total flavonoids and antioxidant activity. *Indonesian Food and Nutrition Progress*, 14(1), 21-28.
- Kacar, B., Katkat, V., & Öztürk, Ş. (2009). *Bitki fizyolojisi* (3 ed.): Nobel Yayın Dağıtım.
- Karabulut, H., & Gülay, M. (2016). Serbest radikaller. *Mehmet Akif Ersoy Üniversitesi Sağlık Bilimleri Enstitüsü Dergisi*, 4(1), 50-59.
- Keser, G. (2005). *Nasturtium officinale R. Br.'de kurşunun strese bağlı enzimlerin aktivitelerine, gelişmeye, mineral ve klorofil içeriğine etkileri*. (pHD). Çukurova Üniversitesi, Adana.
- Kolaç, T., Gürbüz, P., & Yetiş, G. (2017). Doğal ürünlerin fenolik içeriği ve antioksidan özellikleri. *İnönü Üniversitesi Sağlık Hizmetleri Meslek Yüksek Okulu Dergisi*, 5(1), 26-42.

- Liu, J., Wang, C., Wang, Z., Zhang, C., Lu, S., & Liu, J. (2011). The antioxidant and free-radical scavenging activities of extract and fractions from corn silk (*Zea mays* L.) and related flavone glycosides. *Food Chemistry*, 126(1), 261-269.
- Mittler, R., Zandalinas, S., Fichman, Y., & Van Breusegem, F. (2022). Reactive oxygen species signalling in plant stress responses. *Nature Reviews Molecular Cell Biology*, 23(10), 663-679.
- Nanda, A., Andrio, E., Marino, D., Pauly, N., & Dunand, C. (2010). Reactive oxygen species during plant-microorganism early interactions. *Journal of Integrative Plant Biology*, 52(2), 195-204.
- Nikolic, N., Mitrovic, J., Karabegovic, I., Savic, S., Petrovic, S., Lazic, M., & Stojanovic, G. (2019). A comparison between wheat and different kinds of corn flour based on minerals, free phenolic acid composition and antioxidant activity. *Quality Assurance and Safety of Crops & Foods*, 11(4), 341-349.
- O'Brien, J., Daudi, A., Butt, V., & Paul Bolwell, G. (2012). Reactive oxygen species and their role in plant defence and cell wall metabolism. *Planta*, 236(3), 765-779.
- Özcan, O., Erdal, H., Çakırca, G., & Yönden, Z. (2015). Oxidative stress and its impacts on intracellular lipids, proteins and DNA. *J Clin Exp Invest*, 6(3), 331-336.
- Petroni, K., Pilu, R., & Tonelli, C. (2014). Anthocyanins in corn: a wealth of genes for human health. *Planta*, 240(5), 901-911.
- Sade, B., Soylu, S., & Yetim, E. (2011). Drought and oxidative stress. *African journal of Biotechnology*, 10(54), 11102-11109. <https://www.ajol.info/index.php/ajb/article/view/96083>.
- Şerment, M., & Kahriman, F. (2021). Mısırdaki toplam fenolik ve antosiyanin içeriğinin belirlenmesi için geliştirilmiş NIRS (yakın kızıl ötesi spektroskopisi) kalibrasyon modelleri üzerine kemometrik yöntemlerin etkisi. *Journal of Advanced Research in Natural and Applied Sciences*, 7(3), 437-449.
- Türk, G. (2015). Reaktif oksijen türlerinin spermatozoon fonksiyonları üzerindeki fizyolojik ve patolojik etkileri. *Evcil Hayvanların Üremesinde ve Suni Tohumlamasında Antioksidanlar Özel Sayısı*, 1(3), 26-34.
- Žilić, S., Kocadağlı, T., Vančetović, J., & Gökmen, V. (2016). Effects of baking conditions and dough formulations on phenolic compound stability, antioxidant capacity and color of cookies made from anthocyanin-rich corn flour. *LWT-Food Science and Technology*, 65, 597-603.



## **CHAPTER 4**

### **SMART FARMING APPLICATION IN FRUIT HARVESTING**

*M. Barış EMİNOĞLU<sup>1</sup>, Uğur YEGÜL<sup>2</sup>*

---

1 Dr., Department of Agricultural Machinery and Technologies Engineering,  
Faculty of Agriculture, Ankara University [eminoglu@agri.ankara.edu.tr](mailto:eminoglu@agri.ankara.edu.tr), ORCID ID : 0000-0003-3264-3636, (Corresponding author),

2 Dr., Department of Agricultural Machinery and Technologies Engineering,  
Faculty of Agriculture, Ankara University [yegul@ankara.edu.tr](mailto:yegul@ankara.edu.tr), ORCID ID :  
0000-0003-2139-4080,

## Introduction

Smart farming means the planning and management of processes from tillage to post-harvest using modern technology and techniques. Smart Farming provides site specific solutions. During the fruit growing processes, the land and the plants are not considered uniform. The water in the land is considered as variable in terms of soil structure, plant nutrients, climate, and plant disease factors. The principle of making different management plans for these discussed variables are adopted. Different type of sensors, GPS equipment, satellites, unmanned aerial vehicles, software, statistical and machine learning methods are used together or separately for various applications.

While precision agriculture offers site-specific solutions, firstly, the locations of the sampling areas or points on the land are determined. Data can be obtained from sampling points with sensors placed on satellites, aircraft, or unmanned aerial vehicles. Then with the developed software, maps are created from the values of the sampling locations. Administrative decisions can be made by processing the received data by experts, and application steps can be determined by machine learning methods by different algorithms.

One of the most important phases of fruit growing is fruit harvest, which typically entails the collection of mature fruits, their transportation, cleaning, classification, and storage until they can be eaten. There are three distinct ways to harvest fruits: harvesting fruit by hand, semi-mechanized, and mechanized methods.



Figure 1. Mechanic harvesting by machinery (Anonymous a, 2021)

For mechanic harvesting method, the harvest of the fruit is done partially or completely using harvesting machines (Figure 1). Fruits are exposed to various mechanical effects. This method is generally used in fruits harvested for industrial processes.



*Figure 2. Mobile harvest platform (Anonymous b, 2022)*

In semi mechanized fruit harvesting, harvesting assistance equipment combines hand harvesting and machinery. They are mobile vehicles with fixed or mobile platforms. Other processes have been mechanized apart from harvesting.



*Figure 3. Fruit harvesting by hand (Kitinoja ve Kader, 2003)*

The fruit is held with fingers and pulled upwards. Depending on the type of fruit, fruit can be turned and bended around its stem (Figure 1). Hand harvesting of fruits is the preferred method for delicate fruits. However, labor costs have the highest share in fruit production.

They have made room for automatic systems that collect ripe fruit with robotic arms and place them in boxes or special plates by determining fruit maturity with cameras and sensors, in addition to these three general methods. After this section, automation in fruit harvesting, which is an application of smart agriculture, and studies on this subject will be discussed.

### **Smart Farming Applications in Fruit Harvesting**

Research and applications about smart farming applications in fruit harvesting have been divided two main subjects. One of these is yield mapping applications, and other is automation applications.

#### **Yield mapping applications**

These systems allow the amount of grown fruits to be monitored and recorded in smaller subunits. Electronic yield monitoring-recording systems and software have been developed for different products. The yield maps are created to show results of the cultural practices made during the growing period. Regional differences in yield maps are important in terms of planning cultural practices will be carried out for next years.

Swain et al. (2010) developed an automatic yield monitoring and mapping system for blueberry (*Vaccinium angustifolium* Ait.). This system can provide real-time fruit yield estimation. A digital color camera, a positioning system receiver, and a computer mounted on a specially designed vehicle are the system's hardware components. The yield estimation method was expressed as the correlation between the corresponding correlation parameter and the percentage of total image pixels and the estimation of the blue pixels that represented the ripe fruit in the field of view of each image. The "Delphi" and "C" programming languages were utilized in the creation of image processing software.

In Figure 4, the density of the blue pixels filtered from the image taken by the camera with the developed software is seen. Two commercial blueberry fields served as the location for the field trials. The experimental results demonstrate a significant correlation between the actual fruit yield and the percentage of blue pixels in the system for calibration purposes ( $P < 0.001$ ).

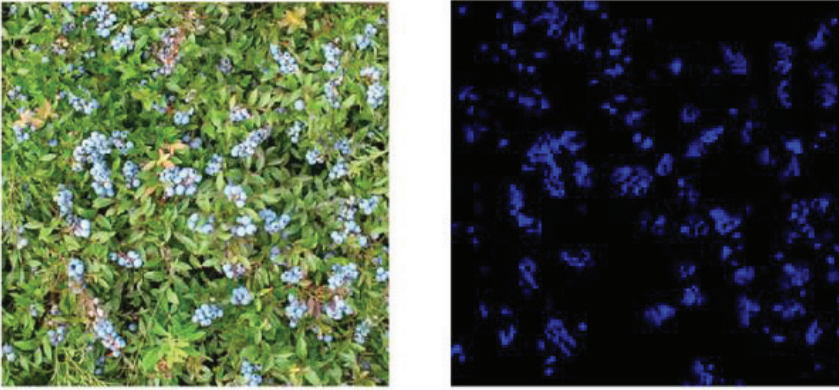

Figure 4. Image from camera(left) and processed image with software (Swain *et al.*, 2010)

In the evaluations made for validation of the system, the correlation between actual and estimated fruit yield was also statistically significant ( $R^2 = 0.97$ ;  $P < 0.001$ ). In addition, fruit yield maps showed significant variation within the studied area, as the basis for implementing site-specific management plans in blueberry fields. It was stated that the created maps can be used to develop site-specific sensitive nutrition programs for yield estimation and blueberry production, as well as maps of topography and plant nutrients.

Maghsoudi and Asadi (2020) developed a pistachio yield monitoring system. They tested this system in the laboratory. Then, the system was transferred to the pistachio orchard. The weight data and the location of each pistachio tree were recorded (Figure 5).

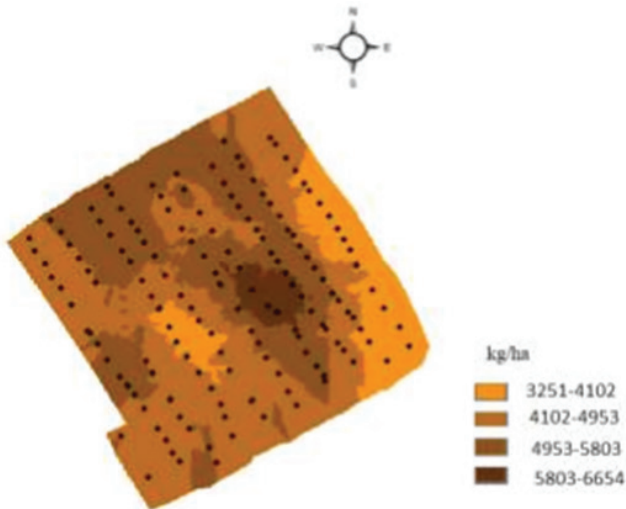

Figure 5. Developed a pistachio yield map

As seen in Figure 5, each black dot represents the location of a pistachio tree in the field. The color intensity on the map changes according to the amount of harvested peanuts. The scale of the map shows that the amount of pistachio harvested for one hectare varies between 3.2 tones and 6.6 tones. Researchers emphasized that When the used methods were compared, the Ordinary Kriging method was determined as the best method due to its lower RMSE (Root Mean Square Error). Finally, the yield map of the product was created with the Ordinary Kriging method in GIS software.

Ampatzidis et al., tried two approaches to develop yield mapping systems for manual fruit harvesting. A DGPS and a long-range RFID reader are mounted on an orchard tractor in the first approach. The safes have low-cost passive RFID tags attached to them. Without using DGPS, RFID tags are inserted one at a time into trees using the second method. The first approach, which combined the RFID reader and DGPS module, was unsuccessful in half of the tests. The fact that tree crowns block GPS signals explains this. For both methods, the RFID reader failure rate for safe detection was found to be 0.32 percent. The second method, on the other hand, emphasized that tree tags should be in a good spot to successfully detect RFID tags. It is expressed that the principal strategy is seriously encouraging on the off chance that the right farm vehicle position can be gotten under the tree crown. The RFID reader's ability to detect and not miss tags attached to trees and partitions is critical to the performance of both proposed methods for matching and location. Consequently, the detection performance must be investigated prior to the experimental evaluation of the methods. The positions and orientations of the tags on the trees are what determine whether or not the RFID reader is able to successfully detect tree tags at a given antenna height. Twenty RFID tags were affixed to twenty tree trunks in two consecutive rows, approximately 0.5 meters above the ground, in order to determine the best positions and orientations. The RFID antenna is positioned in front of the tags, so that each surface's normal vector is in line with the reader axis. The platform was then moved between rows. Two of the twenty RFID tags could not be identified. RFID tags were attached to large branches—not trunks—at 0.9-1.2 meters above the ground in the same orientation for a second round of this experiment. 18 tags were found by the reader. When different label orientations were tested at the same height (0.9-1.2 m), detection was always significantly lower. The RFID tags were permanently attached to the appropriate branches for the remainder of the experiments on the basis of these tests, approximately 1.2 meters above the ground, with their faces oriented along the row and facing the RFID antenna. 160 RFID tags, one for each large side, were attached to 80 empty boxes for the experimental evaluation of

label detection in boxes. The boxes were placed on the ground at random locations under opposite trees. After that, the tractor stopped in front of each pair of trees to identify the barn as it pulled the platform between the rows of trees. On the ground, only thirty boxes (or 37.5%) could be identified. When the workers carried the remaining boxes to the platform, they were identified. On fruit-filled boxes, the same experiment was also carried out. It is stated that additional tests are required to determine the optimal tree tag positions and orientations for successful RFID reader detection. Additionally, if the tag is left on the tree for an extended period of time, it has been suggested that the growth of tree branches and leaves may decrease the rate at which the tag is detected. As a result, it is emphasized that the first approach will be more successful if the interference issues with the GPS signal can be resolved.

Surekha et. al (2020) developed a yield mapping system. This system could be counted fruits with image processing (Figure 6).

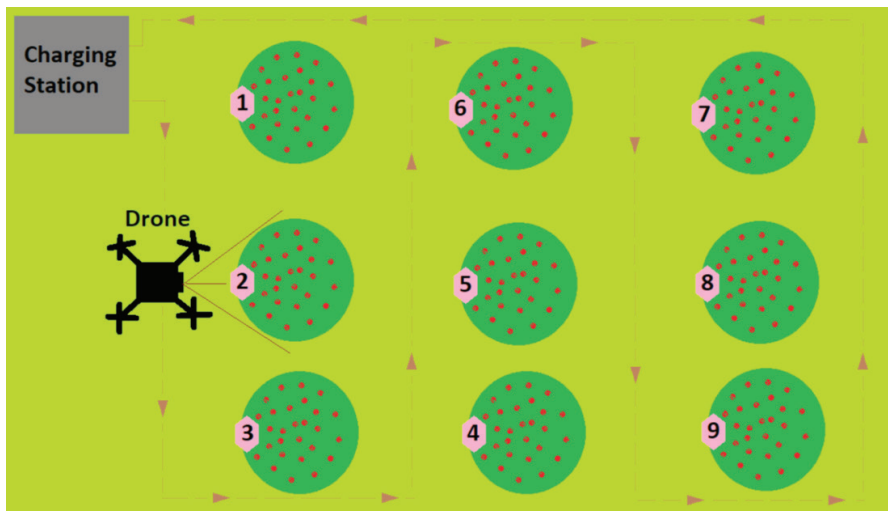

Figure 6. Working plan of the fruit detection drone (Surekha et. al, 2020)

The drone seen in Figure 6, can operate on the determined route. In addition, when its battery is low, it can go to the charging station. When its battery is full, it can continue its task from where it left off. It has been observed that the image processing time increases as the number of photos to be processed and the number of fruits in the photos increase. The success of the image processing system developed in the experiments was found to be 84%.

## Automation applications

Automation in fruit harvesting includes the processes of determining the degree of ripening of fruits without human intervention, determining the location of the ripening fruit in three-dimensional space, separating the ripe fruit from the plant, classifying them according to their various characteristics and placing them in boxes. Robots are used for these processes. The components of the robots used for this purpose are shown in Figure 7.

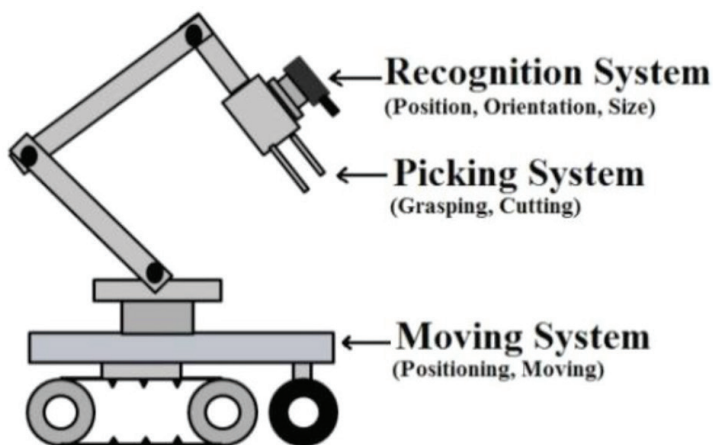

Figure 7. Components of robotic harvester (Bachche, S. 2015).

As seen in Figure 7, these components will be examined in three main groups. These are the moving system, the picking system, and the fruit recognition system, respectively.

- The Recognition system provides identifying fruit, makes a decision about ripeness of fruit and determines the coordinates of fruit in three-dimensional space. These operations are carried out with hardware and algorithms. The most used cameras in the studies on fruit harvest automation; monocular, stereo cameras, spectral and thermal cameras. The most used algorithms are color, shape and texture-based analysis and neural networks approaches.

- The picking system separates the fruit from the tree without damaging and places it in the boxes. Picking systems are classified as electric, pneumatic, and hydraulic grippers. In agriculture, electric and pneumatic grippers have demonstrated good results for single and cluster fruits with high accuracy, repeatability, ease of maintenance, and small size when compared to one another. They are used by fruit harvesting robots because of these properties.

- The motion system, enables the robot to move between the trees on the row during the harvesting process. Harvest robots are moved by tires or crawlers. These tires and crawlers are driven by an electric motor and hydraulic motor. A drive or amplifier is used to change the control signals, and a motion controller is used to generate set points that are used as reference measurements. The robot's motion can be controlled by a number of control functions, including electronic gearing, position control, pressure or force control, and velocity control.

### Robotic application in fruit harvesting

With the advancement of technology, other areas of agriculture As well as in fruit harvesting, studies on robotic applications are increasing. These studies mainly focus on recognizing the ripe fruit, determining its location on the tree, processing this information and deciding on the picking process, without damaging the fruit, designing enough degrees of freedom for picking arms.

Grand D'Enson et al. (1987), developed a picking arm for apple harvest(Figure 8). It is one of the first prototypes on this subject.

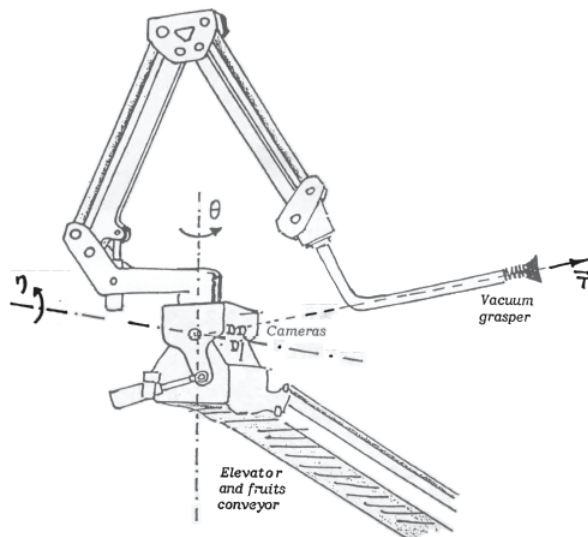

Figure 8. Picking arm for apple harvesting (Grand D'Enson et al., 1987)

This prototype, which they named MAGALLI; a mechanical arm that can move up and down in the vertical direction, a cylinder to which the arm is attached and can rotate on the horizontal axis, cameras centered on the axis of rotation, vacuum gripper placed at the end of the it consists of a conveyor.

Scarfe et al. (2009) designed an autonomous kiwi picking robot(Figure 9). This developed robot performs turns and maneuvers with two thin rubber wheels on the front.



*Figure 9. Kiwi picking robot (Scarfe et al., 2009)*

Radio waves exert control over the robot. Each of the robot's four arms can simultaneously collect fruit. The developed robot is powered by a 7 kW motor and a hydraulic pump that moves it. It can carry harvest products up to 1.5 tons. The fruit is discovered using sophisticated algorithms. It shows where the ripe fruit is on the tree's crown. It gathers natural products in the cases, and when the containers are full, goes to the furthest limit of the line and leaves the boxes.

Agrobot can be used in strawberry harvesting for both the field and greenhouses (Figure 10). This robot has a working width of 6 m and a length of 4 m and row spacing is adjustable. Plants are scanned with color and infrared sensors. If fruit is matured, location of fruit is determined in the three-dimensional plane of space. Then robotic arms pluck the fruit from the stem and place it in the boxes. This robot could be harvest strawberries in daytime and night.



Figure 10. Agrobot (left), fruit recognition and picking systems (right)  
(Anonymous c, 2021)

Tevel Aerobotics Technologies has invented a flying autonomous robot (FAR) that uses artificial intelligence (AI) to identify and pick fruit (Figure 11).



Figure 11. Flying autonomous robot (Anonymous d, 2021)

The robot can pick only ripe fruits and can work around the clock. Fruit, foliage, and other objects can be detected by the software of the flying autonomous robot. Additionally, it can classify fruits. With software for optimizing fleet management, it can plan its course. Another feature of the this application is that six different picking drones work together. This is also an example of robotic systems that can work corporate for the same purpose.

### **Bottlenecks of autonomous fruit harvesting applications;**

Since the 1980s, many studies have been carried out on robotic fruit harvesting. Few of these studies have turned into a commercial product. The main reasons for this can be listed as follows.

- Variation of objects in a crop

There are many different objects such as leaves, branches, unripe fruits, support cables, near the ripe fruits in fruit parcels. These objects

make it difficult to recognize and reach the ripe fruits. Also, the texture and color changes caused by diseases make it difficult to identify the fruits.

- Variation among crops

Different fruits need different recognition and picking methods. Some fruits may be in a clustered structure. This makes difficult to identify the fruit. Breeding companies are always working on new cultivars to improve production or meet new market needs.

- Variation in the production environment

- Different production environments (orchards and greenhouses) with varying lighting conditions are used to grow crops. To support, train, and maintain their crops, growers use various cultivation systems that have an impact on fruit visibility and accessibility.

- Robots must rely on guidance systems for navigation in orchards and open fields, whereas robots can drive on rail systems in greenhouses and indoor environments.

Silwal et al. (2017) referenced that a cutting edge, V-trellis fruiting wall design was chosen for their field studies. The trees were trained in a formal architecture, and the end result was narrow, planar tree canopies with trellis-wired branches.



*Figure 12. Selective tinning application for a V-trellis orchard system (Silwal et al., 2017)*

As shown in Figure 12, this new approach for fruit growing is an example of SNAP approach. It is abbreviation of simple narrow accessible productive (Vougioukas et al, 2016). This term may also appear as fruit walls (Saeys & Nguyen, 2012) in different researches. Robotic harvesting systems can more easily identify and collect the fruits in this type of cultivation systems. This design makes access easier and presents fewer obstructions from adjacent branches than traditional tree canopies, which distribute fruit in three dimensions.

## References

- Ampatzidis, Y.G.; Vougioukas, S.G.; Bochtis, D.D.; Tsatsarelis, C.A. (2009). A yield mapping system for hand-harvested fruits based on RFID and GPS location technologies: Field testing. *Precis. Agric.* 2009, 10, 63–72
- Anonymous a, 2022. Web site: [http://www.tuthilltemperley.com/mk2\\_centipede.htm](http://www.tuthilltemperley.com/mk2_centipede.htm)
- Anonymous b, 2022. Web site: <https://www.abseq.com.au/product/orchard-hydraulic-platform-psh-3/>
- Anonim c, 2021. Web adresi: <https://www.ffrobotics.com>
- Anonim d, 2022. Web adresi: <https://ndion.de/en/flying-autonomous-robots-an-autonomous-drone-as-a-harvest-helper/>
- Bachche, S. (2015). Deliberation on design strategies of automatic harvesting systems: A survey. *Robotics*, 4(2), 194-222.
- Grand D'Esnon, A, Rabatel, G., Pellenc, R., Journeau, A and Aldon, M.J. 1987."MAGALI": a self-propelled robot to pick apples ASAE Paper 87-1037, St. Joseph, MI 49085
- Kitinoja, L. and Kader, A.A. 2003. Small-Scale Postharvest Handling Practices: A Manual for Horticultural Crops (4th Edition). Postharvest Horticulture Series No.8E, July 2002
- Maghsoudi, H., & Asadi, V. (2020). Yield mapping in a pistachio orchard with evaluation of a designed measurement system for manual harvesting (a case study: Manzel-Abad district of Shahr-e Babak). *Journal of Researches in Mechanics of Agricultural Machinery*, 9(1).
- Saeyns, W., & Nguyen, T. T. (2012). CROPS project deliverable 6.3: Report on the plantation and pruning methods to have fruit readily suited for automated harvesting. Leuven, Belgium: KU Leuven.
- Scarfe, A.J., Flemmer, R. C., Bakker H. H. and Flemmer, C. L. (2009). Development of an autonomous kiwifruit picking robot. 4th International Conference on Autonomous Robots and Agents, pp. 380-384, doi: 10.1109/ICARA.2000.4804023.
- Silwal A, Davidson JR, Karkee M, Mo C, Zhang Q, Lewis K. Design, integration, and field evaluation of a robotic apple harvester. *J Field Robotics*. 2017;34:1140–1159. <https://doi.org/10.1002/rob.21715>
- Surekha, P., Venu, N., Shetty, A. N., & Sachan, O. (2020). An Automatic Drone to Survey Orchards using Image Processing and Solar Energy. In 2020 IEEE 17th India Council International Conference (INDICON) (pp. 1-7). IEEE.

- Swain, K.C., Zaman, Q.U., Schumann, A.W., Percival, D.C., Bochtis, D.D., (2010). Computer vision system for wild blueberry fruit yield mapping. *Biosyst. Eng.* 106, 389–394.
- Vougioukas, S. G., Arikapudi, R., & Munic, J. (2016). A Study of Fruit Reachability in Orchard Trees by Linear-Only Motion. *IFAC-PapersOnLine*, 49(16), 277-280 <https://doi.org/10.1016/j.ifacol.2016.10.051>



## **CHAPTER 5**

### **TRADITIONAL CENTENNIAL FLAVOR: SİLİVRİ YOGURT**

*Seval Sevgi KIRDAR<sup>1</sup>*

---

<sup>1</sup> Prof.Dr., Burdur Mehmet Akif Ersoy University Burdur Food, Agriculture and Livestock Vocational School Food Processing Department Dairy and Products Technology Programme ID: <https://orcid.org/0000-0003-4836-7496>

## 1. INTRODUCTION

Yogurt is a fermented dairy product that has existed for a very long time and is now consumed worldwide. It is an acid curd produced by *Streptococcus thermophilus* and *Lactobacillus delbrueckii* subsp. *bulgaricus*, two bacteria that ferment lactose into lactic acid (Tamime&Robinson 2000)

“Yogurt” comes from the Turkish word “yoğurmak,” which means to thicken, coagulate, or curdle (McGee, 2004). It may be related to yoğun, meaning thick or dense—the sound “ğ” was traditionally rendered as “gh” in transliterations of Turkish. The use of yogurt by medieval Turks was recorded in the books *Diwan Lughat al-Turk* by Mahmud Kashgari (Kashgari, 1984) and *Kutadgu Bilig* by K. H. Yusuf (Yusuf, 1983), both written in the 11th century. The texts mention the word “yogurt” and describe its use by nomadic Turks. The Turks were also the first to evaluate yogurt’s medicinal use for various illnesses and symptoms, such as diarrhea and cramps, and to alleviate the discomfort of sunburned skin (Kurmann et al.1992; Fisberg & Machado, 2015).

## 2. YOGURT HISTORICAL BACKGROUND

The origin of yogurt can be traced back to 6000 B.C., when the Neolithic people of Central Asia transitioned from food gatherers to food producers and began milking their animals. This development also involved the domestication of animals (such as cows, sheep, goats, buffalo, and camels), and it is quite likely that this transition took place at different periods in different parts of the world at other points in history. Evidence from archaeology demonstrates that certain civilizations, such as the Sumerians and Babylonians in Mesopotamia, the Pharaohs in north-east Africa, and the Indians in Asia, were highly developed in agricultural and husbandry practices, as well as in the production of fermented milk products such as yogurt (Pederson, 1979). Yogurt was discovered by accident when sheepskin bags were used to store milk and has since evolved into commercial yogurt production, paving the way for a variety of commercially available tastes, shapes, and textures (Weerathilake et al. 2014). Different periods occurred in different parts of the world at other times in history. Evidence from archaeology demonstrates that certain civilizations, such as the Sumerians and Babylonians in Mesopotamia, the Pharaohs in north-east Africa, and the Indians in Asia, were highly developed in agricultural and husbandry practices, as well as in the production of fermented milk products such as yogurt (Pederson, 1979). Yogurt was discovered by accident when sheepskin bags were used to store milk and has since evolved into commercial yogurt production, paving the way for a variety of commercially available tastes, shapes, and textures (Weerathilake et al. 2014). Chomakov (1973) state that the origin of yogurt belongs to the Balkans,

and the natives of Thrace claimed that they made sour milk called “prokish” from sheep’s milk, which later became yogurt.

There are stories and predictions about the first time yogurt was made. One view is that our ancestors, who lived a nomadic life in the steppes of Central Asia and engaged in animal husbandry, discovered yogurt by chance. It is thought that milk may have solidified spontaneously under the influence of bacteria that coagulate the milk by being affected by the natural environment (temperature, microorganism contamination). The cultures of the Oghuz, Seljuks, and Ottomans brought yogurt with them to the countries they ruled (Ozden, 2008).

Yogurt, a common food in Mongolia, is said to have been given to Genghis Khan’s army in order to instill bravery in his soldiers. In the 16th century, the King of France, François I, used many drugs for a febrile gastrointestinal disease but could not recover. The king’s mother asks Suleiman the Magnificent to send a physician to treat her son, François. Sultan Suleiman also sends a Jewish physician to Paris, who is knowledgeable about the king’s illness. Some report that this doctor went to France by ship, taking his goats with him, while others report that he went by land with a flock of sheep. The Jewish Ottoman physician makes yogurt from the milk he milks in secrecy. Then, by adding other ingredients to his yogurt, he prepares the miracle-working product. This ottoman does not give anyone the secret of making yogurt or the mixture he prepared. François I, who recovered from the treatment of the Ottoman physician, named yogurt “the milk of eternal life” (“the milk of eternal life” = “Le lait de Vie éternelle) and asked his physicians to deal with the subject. French physicians, humiliated by the Ottoman physician’s success, were uninterested in this oriental treatment approach (Ozden, 2008).

The United States of America also met with success thanks to yogurt, thanks to the Turks who immigrated to this country in 1784. Mahatma Gandhi gave a special place to yogurt in his book “Diet Reform.” He reported that yogurt has calming and drowsy effects (Kurman e al 1992).

The spherical and rod-shaped lactic acid bacteria present in Bulgarian yogurt were initially described in 1905 by Stamen Grigorov, a Bulgarian medical student studying in Geneva, Switzerland; the species was designated *Bacillus bulgaricus*. Then, in the 20th century, Russian Nobel Prize winner Elie Metchnikoff, a researcher at the Pasteur Institute in Paris, proposed the theory that Bulgarians’ disproportionately long lifespans were caused by their frequent yogurt consumption. Another significant development in the history of yogurt was Isaac Carasso’s conversion of the dish into a retail item in Barcelona, Spain, in 1919. Beginning in the 1960s, Danone, a private firm, advanced the commercialization of yogurt by in-

dustrializing it and distributing it across Europe (Ray & Montet, 2017).

When Isaac Carasso of Barcelona began making yogurt with jams, the product became commercially successful. Daniel Carasso, son of Isaac Carasso, established Dannon after fleeing Nazi captivity (Danone in France). In 1932, the first yogurt laboratory and factory opened in France; in 1941, the first laboratory and factory debuted in the United States (Brothwell and Brothwell 1997).

Between 6500 and 5500 BC, sheep and goat bones were discovered in the lowest layers of excavations at Catalhöyük, near Umra in modern-day Konya, as well as in the kitchen sections of a few houses. Furthermore, the presence of acorns (pelite) in goat bones and the use of acorns as yeast in yogurt production in the region indicate that the ancient people of Atalhöyük knew how to make yogurt (Unsal, 2007, Ozden, 2014).

The famous traveler Evliya Celebi (1611-1682), who traveled the Ottoman country for more than forty years in the seventeenth century, mentions yogurt and dishes with yogurt in her “Travelnâme.” (Yerasimos, 2011). Guillaume-Antoine Oliver (1756-1814) worked as a French physician and entomologist in the Ottoman Empire, Iran, for six years. In his work titled “Le voyage dans l’empire Ottoman, l’Égypte, et la Perse” (1807), which he wrote after returning from his trip to Egypt in 1798, yogurt was widely consumed in all Eastern countries. He writes that foreigners do not like it, but that it is a healthy food that is quickly used and eaten with pleasure and taste (Gokmen, 1977).

Ibn-i Erif’s (d. 1461) “Yadigar” II was one of the first five medical books written in Turkish during the Ottoman period. It is thought to have been written for Umur Bey, the son of Timurtaş, who was a governor during Murat’s pasha reign in Bursa (1421-1428). This book contains the following information about treatments using yogurt (Yurdakok, 2013).

## **2. YOGURT MARKET AND CONSUMPTION IN WORLD and TURKEY**

The health advantages of consuming yogurt have been widely recognized for millennia. Due to its excellent digestibility and nutrient absorption, yogurt is a healthy food that can be suggested lactose intolerance, gastrointestinal illnesses such as inflammatory bowel disease and irritable bowel disease, and it supports immunological function and weight control. Yogurt is the market’s fastest-growing dairy category because of its beneficial health effects; this includes both regular yogurt and yogurt drinks. (Tamime & Robinson 2000; Mckinley, 2005).

The types of yogurt that people consume nowadays are influenced by regional traditions or suit specific lifestyles. For instance, the largest per

capita yogurt consumption is found in the Netherlands, France, Turkey, Spain, and Germany (Figure 3) (Jiang 2022). In contrast, the countries with the lowest per capita yogurt consumption are Egypt, Colombia, Russia, Romania, and South Africa (Fisberg & Machado, 2015). In 2020, the market for yogurt was estimated to be around \$97.999,5 million, and by 2031, it is expected to be worth \$171.826 million. Yogurt was produced in the European Union (EU27) on a total scale of about 7.57 million tons in 2021 compared to 7.85 million tons in 2016. With a production output of almost 1.75 million tons, Germany was the biggest producer of yogurt in Europe. With over 1.34 million tons of yogurt produced in 2021, France came in second. With almost 937,280 tons of yogurt produced, Spain came in third (FAOSTAT, 2021). Yogurt, which is the most consumed fermented milk product in Turkey, can be consumed in different ways: concentrated (dried or in the form of strained yogurt), drinkable (ayran), or flavored (garlicky, spicy, fruity, etc.) It can also be used as an important food component in preparing meals (tarhana, yogurt soup, etc.,) (Horzum 2016).



Figure 3. Per capita consumption of yogurt (kg) in different countries (Jiang 2022)

Strained yoghurt, winter yoghurt (salted and cooked yoghurt), tulum yoghurt, Silivri yoghurt, burnt-smelling strained/pouch yoghurt, Kayseri Bünyan pine glass strained yoghurt, Burdur Kökez strained yogurt, and dried yoghurt are traditionally produced and consumed in different cities and regions. (Unsal, 2007, Sacak 2022).

In 2021, the amount of yogurt that was produced in Turkey was 1.12 million tons, representing a growth rate of 1.7%. Turkey is one of the countries that makes and consumes the most yogurt, with an average of 29



kilograms per person per year (USK, 2021).

There are around 400 different generic names that are used to refer to the traditional and commercial fermented milk products that are produced all over the World (Table 1). The particular names of these concentrated fermented milks depend upon: i) region of the world ii) Type of milk used (cow, goat, sheep or buffalo), iii) Microbial cultures that dominate(s) the flora and iv) Borrowed or made-up names. (Kurmann et al., 1992).

### **3. TRADITIONAL YOGURT AND GEOGRAPHICAL INDICATION IN TURKEY**

Traditional foods are crucial for preserving cultural history for future generations as well as for local identity, consumer behavior, and interactions with other cultures. Traditional food production and sales are a significant source of income for many communities, and they can help rural areas diversify their economies and maintain population density. (Guerrero, et al. 2010). Particularly traditional meals can be utilized as branding and marketing tools and are crucial for validating an ethnic or national culture (DeSoucey, 2010; Ferguson, 2010). Traditional foods, also called local products, are foods produced using traditional methods. They are products that are produced by a traditional production method (Vasilopoulou et al., 2005) as a result of the combination of traditional raw materials with traditional recipes and that contain their culture, history, and lifestyles, which come from different regions and differ from their counterparts with their own characteristics (Kusat, 2012). These foods are associated with special celebrations and/or periods or are frequently consumed; they are often passed down from one generation to another, produced in a special way with little or no manipulation as part of the gastronomic heritage; they are distinguishable from other foods due to their sensory properties; and they are associated with a particular local area, region, or country are original products (Guerrero et al., 2009; Cumhur, 2017). The use of traditional components, which are a reflection of history, culture, geography, agriculture, climate, and lifestyle, as well as the fact that production, presentation, consumption, or storage conditions are locally particular, distinguish the product and give it unique qualities (Cumhur, 2017).

Table 1. List of Yogurt and Yogurt-Like Items Discovered in the Middle East and Worldwide

Region	Traditional name	Country
<p>Europe</p> 	<p>Yogurt Kissel mleka/naja/yaour Urgotnic Yiaourti Cieddu Mezzorad Mezzoradu Tarho/taho Viili Filmjolk/fillbunke/ filbunk/surmelk/taettem Skyr Gruzoviz Logurte</p>	<p>Turkey Balkans Balkan mountains Greece Italy Sicily Sardinia Hungary Finland Scandinavia Iceland Yugoslavia Portugal</p>
<p>Eurasia</p> 	<p>Donskaya/varenetes/ kurugna/ryzhenka/ guslyanka Busa Mazun/matsoon,matsun, matsoni, madzoon Katyk</p>	<p>Russia Turkestan Armenia Transcaucasia (South Caucasian state was once extended across the modern-day countries of Armenia, Azerbaijan, and Georgia)</p>
<p>Middle East and Asia</p> 	<p>Leban/labani  Zabady/zabade Mast/dough/doogh Roba/rob Dahi/dadhi/dahee Tarag Shosim/sho/thara</p>	<p>Lebanon and some Arab countries Egypt and Sudan Iran and Afghanistan Iraq India Mongolia Nepal</p>

Note: Adapted and modified from Tamime & Robinson (2000)

The sustainability of traditional foods and the preservation of production methods are thanks to small-scale family enterprises. These enterprises not only contribute to the local market but also create additional income for our women. While our women learn about food safety, their desire to collaborate helps to market these foods (Ozdemir et al., 2017). However, the limited production capacity and the fact that they are produced with

traditional methods make it difficult for them to compete in the market (Fito and Toldra, 2006).

The European Union, which contributed the most to the economic value of traditional foods, made its first legal initiative on July 14, 1992, with the regulation numbered 2081–2082/92. The regulation included geographical and origin marking for agricultural and food products and issuing certificates for them. In addition, in the regulation, it has been registered as “Protected designation origin (PDO),” “Protected Geographical Indication (PGI)” and “Traditional Characteristics Guarantee (TSG)” (TURKPATENT 2022).

Geographical indication (GI) has emerged as a crucial labeling strategy for communicating information to consumers about the origin and features of the product. By definition, a GI designates goods with a particular geographic origin and with characteristics or a reputation attributable to that origin (Ingram et al., 2020). With the geographical indication (GI) registration, it is aimed to make the products identified with a certain area into a brand, to protect the quality of the products, to support the manufacturer, to transfer national values to future generations without deterioration, and to support rural development (Ozdemir, 2012). Local products under protection with GIs have an important economic potential. While the employment to be created by the production of these products plays an important role in the economic development of the region’s population, the added value created causes the income gap between rural and urban areas to close and the income distribution between regions to be evenly distributed (Kantaroglu & Demirbas, 2018).

Turkey is one of the countries in the world with a very high GI potential. According to the data of the Turkish Patent and Trademark Office (TURKPATENT) in Turkey, there are about 2500 products that can obtain geographic indication registration (Cakmakcı & Salık 2021). As of November 2022, 1250 products have been taken under protection with a GI registration certificate, and 720 products for which an application has been made are in the evaluation phase.

According to TURKPATENT’s data, in the distribution of registered GIs by product groups, food products (chocolate, confectionery, and derivatives, processed and unprocessed meat products; meals and soups; oils; alcoholic and non-alcoholic beverages; dairy products; processed and unprocessed fruits and vegetables; honey; bakery and pastry products; and condiments for food) accounted for 83.5% of the total with 1044 registrations, while handicrafts and others accounted for 16.5% with 206 registrations. Dairy products [55 pieces: 34 cheeses, 2 butters, 4 creams, 9 yoghurts, 2 ice creams, 2 ayrans, and 2 others (Bolu Keş and Gerede Keş)]

constitute 5.3% of the share in food products. While it constitutes 2.7% of the total registered products, it has a rate of 61.8% among dairy products. The number of dairy products for which GI applications have been made is 19. This value constitutes 4.58% of the total 720 products at the application stage (TÜRKPATENT, 2022) .

In the milk and dairy products group, a total of 55 products in Turkey have been registered with CI. The number of registered yoghurts among these products is nine (Table 2).

Traditional Anatolian yoghurts are produced and consumed throughout Turkey, sometimes as medicine and to cure the sick, and sometimes as a soup that fills the stomach, turns it into ayran, and cools it, and is an essential part of Turkish table culture (Horzum, 2016). In the South-east and Eastern Anatolia regions (Kars, Van, rnak, and Elâz), “Kurut” is served with soup, ravioli, and some local dishes.”Winter yogurt” is a type of yogurt produced traditionally in the Mediterranean (Hatay), Central Anatolia (Sivas) and Eastern Anatolia (Bingöl) (Horzum, 2016). Some of our traditional yoghurts are “Tulum yogurt” in Antalya, “Dorak Yogurt” in Kayseri and Niğde, “Kulek yogurt” in Isparta and Trabzon, “Burnt yogurt” in Denizli, and “Kökez yogurt” produced in the Kökez village of Burdur. “Silivri yogurt” has been produced in the Thrace region since the 1870s (Unsal, 2007; Horzum, 2016).

*Table.2. Registered Yoghurts with Geographical Indication*

Products name	Registration type	Province	Registration date	Registered Organization
		Zonguldak	08.05.2020	Çaycuma Chamber of Commerce and Industry
		Mersin province Silifke district	07.02.2022	Silifke Chamber of Commerce and Industry
		Istanbul province Silivri district	26.07.2022	Silivri Municipality

 Mamak Ravak Yogurt		Ankara province Mamak district	06.08.2021	Mamak Municipality
 AFYONKARAHİSAR MAINDA Yoğurdu		Afyonkarahisar province	27.07.2021	Afyonkarahisar Chamber of Commerce and Industry
 Antakya Tuzlu Yoğurdu		Hatay province	10.09.2020	Antakya Chamber of Commerce and Industry
 Emirdağ Koyun Yogurt		Afyonkarahisar province Emirdağ district	06.09.2021	Emirdağ Municipality
 EREGLI Koyun Yoğurdu		Konya province Ereğli district	12.07.2021	Konya Ereğli Municipality
 Eşmekaya Yogurt		Aksaray province Eskil district Eşmekaya town	25.05.2021	Aksaray Commodity Exchange

Resource: [www. ci.turkpatent.gov.tr](http://www.ci.turkpatent.gov.tr)

#### 4. SİLİVRİ YOGURT

Silivri District is located in the western part of Istanbul Province, in the southwest of the Catalca Peninsula. The district is located in the north and east of the Catalca district in the southeast. It is adjacent to the Büyükçekmece district, the Sea of Marmara in the south, and Tekirdag Province in the west. The area covered by these borders is 778 km. Silivri was one of the food stores in Istanbul during the Ottoman period. The semolina flour, wine, and yogurt of the Silivri region, where agricultural production is high, were famous. It is unknown by whom or when Silivri yogurt was created.

The Silivri region, which has maintained its importance throughout history due to being a natural port, was an important trade area during the Ottoman Empire. Due to its location on the roads and relative proximity to Istanbul, it has become a frequent destination. Also, Silivri, which has fertile lands and is good for farming, is mentioned as the place where the grain for the palace came from (Yaygın, 1999).

In 2022, Silivri yogurt was registered with the Silivri Municipality as a geographic indication. Geographical indication means that a product originates from a region, area, or region whose geographical boundaries are determined, is identified with that region, area, or region in terms of its distinctive quality, reputation, or other characteristics, and that at least one of the production, processing, or other processes is specified in the specified region, area, or region. It is a sign that indicates the name of that region, area, or region, provided that it is done within its borders. If at least one of the production, processing, or other processes of the product has to take place in a geographical area with defined boundaries, the geographical indications in this situation are called “origin marks” (Tekelioglu, 2021).

The milk used in production is supplied from the Silivri district. As a result, all stages of Silivri Yoghurt, which has a reputation for being geographically borderless, are carried out within the specified geographical border. Silivri yogurt is a thick, yellow yogurt with a thick, creamy layer made from half cow milk and half sheep milk or half cow milk and half buffalo milk. The distinguishing features of Silivri Yoghurt according to the type of milk used in production are given in Table 3.

*Table.3. The distinguishing features of Silivri yogurt*

Type of milk	Fat (%) (min)	non-fat dry matter (%) (min)	Cream (g/1 kg) (min)
<b>Cow milk</b>	4	10	40
<b>sheep milk</b>	5,5	12	50
<b>buffalo milk</b>	6	11,5	70
<b>50% cow + 50% sheep</b>	5	11	45
<b>50% cow + 50% buffalo</b>	5,5	11	60

Resource: TURKPATENT, (2022)

#### **4.1.History of Silivri Yogurt**

One of the steps of milk and dairy product production in Silivri, which is related to agriculture and animal husbandry, has been the production of yogurt, and Silivri yogurt has become well-known throughout the country.

Zeki Öztanrısever, in his 1940 work titled “Silivri Yogurtism,” states that the yogurt that started to be produced in Silivri at the end of the 19th century lost some of its producers as a result of the exchange between Turkey and Greece after a few decades, but that those who came to the town from regions such as Drama, Naslıç, Thessaloniki, and Serez made up for it. He claims that yogurt production is kept alive by locals learning the craft.

Silivri yogurt can be seen even in British Naval Intelligence records found in Marmara after World War I. For example, in the 1920 intelligence report, the phrase “Silivri exports cheese, tobacco, pulses, and yogurt (between March and July) daily to Istanbul by ferryboats” states that the city is one of the production centers feeding Istanbul, and yogurt has become one of the traded goods (Horzum 2016).

The elapsed time indicator in the records is associated with the availability of raw materials. It is known that yogurt production at the beginning of the 20th century was carried out between March and August due to the increase in the amount of milk obtained in the spring and the decrease in the production costs of yogurt thanks to the increasing air temperatures. In addition, the use of sheep’s milk in its production and the fact that the milk is boiled more than once during production distinguish Silivri yogurt from other products. In this context, the reason why Silivri yogurt is especially famous in the Marmara basin can be seen in its relative proximity to Istanbul, as well as the difference in raw material and production stage (Horzum 2016). Although it is not known in which year the yogurt houses in the center of Silivri were built, Üresin said, “Silivri states that [the town] has been known for its yogurts for 40–50 years,” and Kozanoğlu stated that it was used as a yogurt house in Silivri until the 1930s (Unsal 2007). He writes that no places were built for use but that yogurt was produced in warehouse-like structures from the 1870s until now. Since the documents on Silivri and yogurt production in the Prime Ministry Ottoman Archives coincide with the dates 1317–1323 (1899–1905), it is concluded that yogurt production was taking place in the Silivri region in the first years of the 20th century (Unsal 2007).

The history of Silivri yogurt dates back to the 1870s. In Silivri, yogurts produced in yogurt houses built for the sole purpose of making yogurt were transported to Istanbul by sea and distributed. When the cream layer of the yogurts transported to Istanbul deteriorated due to shaking and complaints began to appear, methods specific to the geographical border were developed to prevent the cream from spoiling. Silivri yogurt, which started to be sent to big cities such as Izmir and Ankara in the 1930s, has a connection with the geographical border (Yaygın, 1999).

## 4.2.Silivri Yogurt Houses

Boiler furnaces are part of yogurt houses and caravans. Üresin stated that it consists of two main sections, namely the quarries section (Figure 4), and that some yogurt houses consist of singular spaces. Moreover, it adds the information that these two parts work together. Boiler furnaces made of stone and brick in yogurt houses with two sections rise to 50 cm. The caravan hearths, where the milk is cooked a second time, are similarly made of stone and brick and consist of counters approximately 50 centimeters high. Caravans are placed on the stoves, used on one side when on the side of the wall, and double-sided on the middle sections. Finally, it is stated that there is a third place that functions as a warehouse in some yogurt houses (Sarisakal 2018).

Buildings with masonry and hipped roofs are covered with tile roofs, wooden doors, and natural materials. In addition, there are rectangular window openings with stone jambs. In the photographs taken from different perspectives (Figure 5), it is seen that the window openings of the buildings in the north are located on the higher parts of the walls(Sarisakal 2018).

The fact that the windows are located high and opposite each other creates air circulation, which is essential in the production phase of yogurt and ensures that the yogurt houses are cooled, especially in the summer. Yogurt houses are built with four walls. It is defined as structures that have a covered area with a height of 5-8 meters, including the roof; the dimensions vary depending on their capacity (Sarisakal 2018).



*Figure.4. In front of a Silivri yogurt house in the 1940s yoghurt makers(Photograph:Beril Sarisakal)*

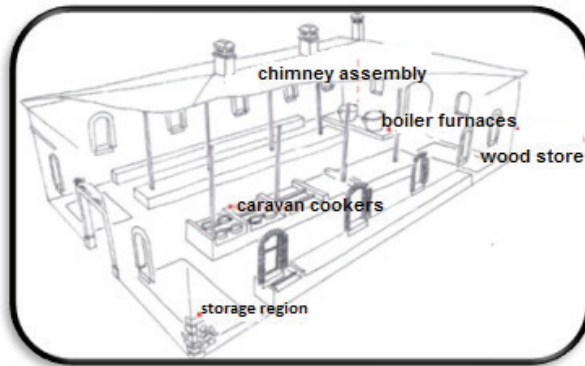

Figure.5 Yoghurt House (Photograph:Beril Sarisakal).

Silivri yogurt is also produced in yogurt houses near Catalca, Mimar Sinan, and Orlu, in addition to Silivri; it is estimated that there were 12 to 17 yogurt houses in the mentioned regions in the second quarter of the twentieth century (Sarisakal 2018).

### 4.3.Silivri Yogurt Production

Yogurt production is carried out in two ways: traditional and industrial.

#### 4.3.1.Old yogurt house style Silivri yoghurt (According to Yaygın 1999)

Expressed milk is poured into a large bucket by filtering it with a cloth. Fresh milk is then put into carboys (bowls), a stick is inserted into it, and the milk is aerated by turning it without closing their mouths. Because the aerated milk is not cut off, it is poured one at a time into the copper cauldron. While the milk is cooked in the cauldron over a wood fire, milk pans (also called caravans or trays) placed on iron grills are ready on brick benches with concrete legs. The wood reverts to embers over and over. The milk is cooked at 90°C, put into small 10-kilogram vats, and poured into trays ( Yaygın 1999).

A tray holds 6-7 kilos of milk and is 40 cm in diameter. It is poured into trays, starting at the bottom and moving thinly upward. The trays are well filled because the foam will go down over time, leaving a gap. When the foam is gone, the cavity of the trays is refilled with this milk. When the temperature of the sheep's milk in the trays drops to 65°C (57°C for buffalo milk, 59°C for cow's milk, and 58°C for mixed milk), charcoal wood and a little charcoal are mixed at the bottom of each tray, and a small shovel is placed. Cooking is light, so setting the charcoal is important. While the fire is cooking the milk lightly, it throws the cream up, where it thickens

and turns yellow. The embers gradually begin to turn into ashes, and the faces of the trays gradually turn yellow. When the time comes, the embers and ashes left under the trays are collected and removed with a squeegee. The trays are expected to be open. In summer, yeast is hit at 42°C, and it goes down to 35-40°C depending on the season. Yeast is made from yogurt. If you mix yogurt with water in a bowl and make yeast, it becomes slightly sour. It will be sweeter if lukewarm milk is mixed with yogurt yeast, a little milk, and a little water. Yeast is added with a small glass syringe with a thicker nozzle. It is drawn from the bowl with a syringe, and 3–4 shots are shot in different parts of each tray. Then, each tray is wrapped in a clean cloth and covered with thin and long wooden slats, as if it were a cage. According to the season: 2.5–3 hours in summer, 4-5 hours in winter. When the yoghurt holds, the tops of the trays are opened, and the yoghurts cool for a while on their own. Then it is placed in the refrigerator. The yogurt is cut when the trays are placed in a hot cupboard (Yaygın 1999) (Figure.6) (Ünsal 2007).

#### **4.3.2. Traditional production of Silivri Yoghurt**

It is made in yogurt houses, which consist of two parts: the boiler room, where the milk is cooked, and the caravan stoves, lined up side by side at a height of 30 to 40 cm from the ground, where the fermentation is made (TÜRKPATENT, 2022).

After the acidity test is performed on the milk brought to the yogurt shop, the milk is filtered through cheesecloth or a fine sieve and transferred to the cooking pots. The milk is pasteurized at 84–90 °C for 150 minutes by stirring vigorously with special wooden paddles called “pala” so the bottom does not stick. During this process, the milk’s water evaporates significantly, and the amount of dry matter increases. Pasteurized milk is filled into glass or earthenware containers (1, 2, 3, or 5 kg, depending on preference). Pouring or filling into containers is done from a height, and the foams formed during this process ensure that the cream layer is shaped and fluffy. These containers are then placed in water-filled caravans (boats) made of copper or stainless steel. Care is taken to ensure that the water level in the caravans is slightly above half the level of the containers. Containers of the same height are put in the same caravans (Yaygın 1999; Kırdar et al. 2014; TÜRKPATENT, 2022).

Silivri Yogurt is cooked for 30 to 60 minutes at 70 °C by lighting a fire under the caravans where the containers are filled for the second cooking or heating, called “cream cooking,” which gives Silivri Yogurt its distinctive feature. During this period, the oil layer collects on the containers and forms a thick cream layer. At the end of the process, the fire or flame at the bottom of the cauldrons is turned off, and the milk is left to cool on its

own so that it drops to 42-43 °C, which is the fermentation temperature. Then, the pre-prepared starter culture is added with a syringe (syringe) at a rate of 1.5–3%, 2-3 cm from the side, to the milk in the containers to avoid disturbing the cream layer. After the starter culture is added, the caravans in which the containers are placed are covered with clean cloth sacks, the windows are closed, and the milk is left to ferment for 3–4 hours. After the fermentation is finished (clot formation is controlled), the covers are removed, the windows are opened, and the yogurt is expected to cool completely. After the yogurts taken to the cold air rooms ( $4\pm 2^{\circ}\text{C}$ ) have cooled down thoroughly (at least 6 hours), the plastic covers of the containers are closed, they are placed in boxes, and they are made ready for shipment. The shipment of yogurts is made by vehicles equipped with cold air ( $4\pm 2^{\circ}\text{C}$ ), and the cold chain is continued until they meet the consumer. The shelf life of traditionally produced Silivri yogurt is 15 days if the cold chain of  $4\pm 2^{\circ}\text{C}$  is not broken (Figure 7). (Yaygın 1999; Kırdar et al. 2014; TÜRKPATENT, 2022).

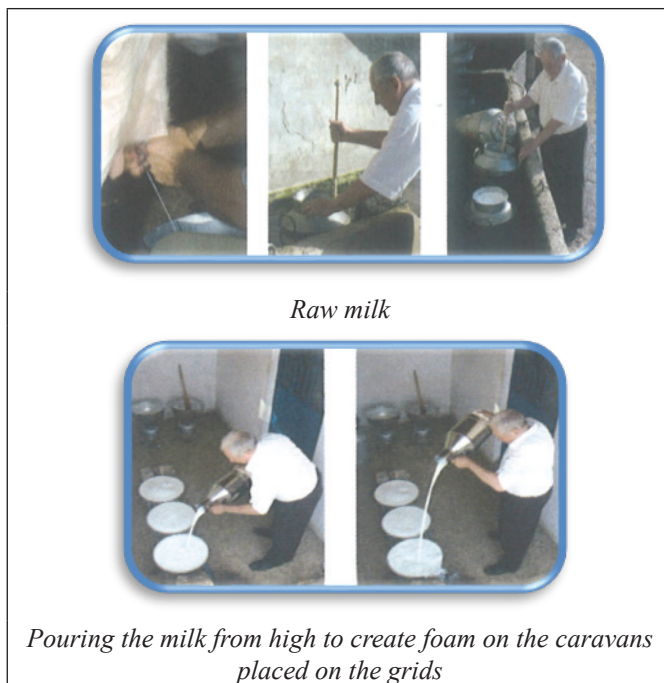



*Placing cores under caravans Re-cooking milk  
(40-60 minutes at 70-90°C)*



*Laths are placed on the fermented caravans, and the  
incubation temperature is kept constant by covering them  
with American cloth and sacks. Incubation continues for 3-4  
hours at 40-45 °C.*



*When the yoghurt is formed, the trays are opened and the  
yoghurts cool for a while on their own. Then it is placed in  
the refrigerator.*

Figure 6. Flow diagram Traditional Silivri Yogurt (adapted from Unsal 2007)



Figure.7. Silivri yogurt

### 4.3.2- Industrial Production of Silivri Yogurt

After tests for acidity, fat, dry matter, and antibiotics are made for the milk brought to the facility, the suitable milk is accepted and passed through the cleaning separator. In productions made from 100% cow's milk, dry matter and fat are standardized. Preferably, the milk is heated under vacuum at 75–85 °C until its non-fat dry matter rises to at least 10% and its fat to 4%. This process is not done in the mixture of buffalo and sheep milk. Next, dry matter and fat-standardized milk are pasteurized by heat treatment at 90–95 °C for 30 minutes. Finally, pasteurized milk is filled hot into containers (optionally 0.5, 1, 3, or 5 kg of glass or earth). The yogurt containers placed on the four-story, stainless steel yogurt trolleys are taken to the fermentation room, and the room is heated to 45–50 °C by turning on the hot air fans before filling. Hot air fans are operated continuously during the filling of milk into containers (Yaygın 1999; TÜRKPATENT, 2022).

The milk is filled into the containers by lifting the filling hose or pipe and pouring it from a height to form foam. When the filling process is finished, the doors and windows of the fermentation chamber are closed, and the room temperature is ensured not to fall below 50 °C with hot fans. This way, the rooms with hot-filled containers are heated with fans for at least 2 hours. These processes are essential for forming a rough and thick cream layer, which is the distinguishing feature of Silivri Yogurt. At the end of the holding period, the steam valves of the room fans are closed, the ventilation fans are opened, and the milk is cooled down to the fermentation temperature of 45–48 °C. The pre-prepared 1.5–3% starter culture is added to the cream-cured milk by cooling it down to the fermentation temperature with a fermentation gun placed 2–3 cm from the side of the container, without disturbing the cream layer. The ventilation fans of the fermentation rooms are turned off again, and the hot air fans are turned on so that the room temperature is 42–45 °C. At the end of the fermentation period of approximately 2–3 hours (until pH = 4.6), the hot air fans are turned off, the ventilation fans are turned on, and the yogurts are brought to room temperature in a short time. Then, the cars with the yogurt containers are taken to the cold air rooms and cooled down to 4±2 °C (at least 6 hours). After the cooling process, the plastic lids of the yogurt containers are closed, stacked in boxes, and made ready for shipment (Yaygın 1999; TÜRKPATENT, 2022). The shipment of yogurts is made by vehicles equipped with cold air (4±2 °C), and the cold chain is continued until they meet the consumer. The shelf life of industrially produced Silivri yogurt is 20 days if the cold chain of 4±2 °C is not broken (Yaygın 1999; TÜRKPATENT, 2022).

### 4.3.3. Silivri Yogurt Festivals

The Silivri Yogurt Festival, which has been held every year since

1962, has recently ceased to be national and has started to appear in the international arena. It is held in mid-July. It was held for the 60th time this year. During the festival, there are tournaments, talks, competitions, fun activities, dance performances, concerts, and special shows. The festival, organized by the municipality due to the fame of Silivri yoghurt beyond borders, has been recognized as one of the region's most popular festivals since its inception. Not only in Turkey, but also from many parts of the world, people actively participate in the festival. In the festival, which has a wide variety of program content ranging from traditional yogurt eating and fermentation competitions to cycling tournaments, famous artists entertain the participants by taking the stage. Each tournament held during the festival has cash and gift prizes. Thus, those who complete the tournament and races with a rank crown their success with festival souvenir gifts and awards (Figure 8). The festival, which has become a traditional cultural activity for Silivri, is very effective in reaching the wider masses of the region every year (Anonim, 2022).



*Figure 8. Silivri Yogurt Festival*

## CONCLUSION

Yogurt is a traditional cuisine that has been consumed by humans for thousands of years and has long been marketed as a nutritious food. Yogurt aids digestion and provides people with enough micro- and macronutrients. Although yogurt has health benefits, it also contains germs that pose a threat to human health and food safety. Traditional yoghurts produced in Turkey should be classified by considering their different characteristics; their production technologies should be developed and standardized; they should be recorded; more yoghurts should be registered; a regular and updated database of properties and compositions should be created; and yoghurt routes should be created and promoted to the world through gastronomic tourism.

## REFERENCES

- Anonim (2022). <https://www.silivriyiz.com/silivri-yogurdu/silivri-yogurt-festivali-nedir-ne-zaman-duzenlenir-h16163.html>. (Erişim Tarihi:05.11.2022)
- Brothwell, D. R., & Brothwell, P. (1998).** *Food in antiquity: a survey of the diet of early peoples* JHU Press.
- Cakmakçı, S., Salık, M.(2021).** Türkiye'nin Coğrafi İşaretli Peynirleri. Akademik Gıda 19(3), 325-342.
- Chomakow H. (1973)** *The Dairy Industry in People's Republic of Bulgaria*, booklet, Agric. Acad, Bulgaria.
- Cumhur Ö (2017).** *Geleneksel Gıdaların Endüstriyel Üretime Aktarılması*. 1.Uluslararası Turizmin Geleceği Kongresi: İnovasyon, Girişimcilik ve Sürdürülebilirlik, 28-30 Eylül, 2017, Mersin, Türkiye, s:396-401.
- DeSoucey, M. (2010).** Gastronationalism: Food traditions and authenticity politics in the European Union. *American Sociological Review*, 75(3), 432-455.
- FAOSTAT, (2021).** <https://www.fao.org/faostat/en/#data>
- Ferguson, P. P. (2010).** Culinary nationalism. *Gastronomica*, 10(1), 102-109.
- Fito P, Toldra F (2006).** Innovations in traditional foods. EFFOST 2005 Conference. *Trends in Food Science and Technology*, 17(9), 129.
- Fisberg, M., & Machado, R. (2015).** History of yogurt and current patterns of consumption. *Nutrition reviews*, 73(suppl-1), 4-7.
- Gokmen O. (1977).** *Türkiye Seyahatnamesi: 1790 Yıllarında Türkiye ve İstanbul* (Olivier'in Osmanlı İmparatorluğu Seyahatnamesi'nden Çeviri). Ankara: Ayyıldız Matbaası, 173.
- Guerrero L, Guardia MD, Xicola J, Verbeke W, Vanhonacker F, Zakowska S, Sajdakowska M, Sulmont C, Issanchou S, Contel M, Scalvedi ML, Granli B, Hersleth M (2009).** Consumer-driven definition of traditional food products and innovation in traditional foods. A qualitative cross-cultural study. *Appetite.*, 52(2),p:345–354.
- Guerrero, L., Claret, A., Verbeke, W., Enderli, G., Zakowska-Biemans, S., Vanhonacker, F., & Hersleth, M. (2010).** Perception of traditional food products in six European regions using free word association. *Food quality and preference*, 21(2), 225-233.
- Horzum RA (2016).** *Türkiye'nin Yoğurt Atlası*. Yüksek Lisans Semineri, Mehmet Akif Ersoy Üniversitesi Sağlık Bilimleri Enstitüsü, Burdur, Türkiye.
- Ingram, V., Hansen, M. E., & Bosselmann, A. S. (2020).** To label or not? Governing the costs and benefits of geographic indication of an African forest honey value chain. *Frontiers in Forests and Global Change*, 3, 102.

- Jiang, Y. (2022).** The Health Effects of Yogurt and Its Safety Hazards. *Highlights in Science, Engineering and Technology*, 19, 119-124.
- Kantaroglu M, Demirbas N (2018).** Türkiye’de coğrafi işaretli gıda ürünleri üretim potansiyelinin değerlendirilmesi. VIII. IBANESS Kongreler Serisi. Nisan 21-22, Plovdiv, Bulgaristan.
- Kashgari M.(1984).** *Divan-Lugat at-Turk*. Tranlated by R. Dankoff with J. Kelley as A Compendium of Turkish Dialects. Vol 2. Cambridge, MA: Cambridge University Press.
- Kırdar, S.S., Akın, M.B., & Akın, M.S. (2014).** *Silivri Yoghurt*, AGRIBALKAN- Balkan Agricultural Congress, 583s. 8-11 Semp., Edirne.
- Kurmann, J.A., Rasic, J.L. & Kroger, M. (1992).** *In Encyclopedia of Fermented Fresh Milk Products*, Van Nostrand Reinhold, New York.
- Kusat N (2012).** Bölgesel kalkınmada geleneksel gıda ürünlerinin rolü ve geleneksel gıdalarda inovasyon belirleyiciler üzerine bir çalışma: Afyon örneği. *Yönetim ve Ekonomi*, **19(2)**, s:261-275.
- McGee, H.(2004).** *Fresh fermented milks and creams*. In: P Dorfman, J Greene, A McGee, eds. *Food and Cooking: The Science and Lore of the Kitchen*. New York: Scribner; 2004; 44–51.
- Mckinley, M. C. (2005).** The nutrition and health benefits of yoghurt. *International journal of dairy technology*, 58(1), 1-12.
- Ozdemir G, Yılmaz E, Unakıtan G, Yılmaz İ, Keskin G (2017).** Kırsalda kadının geleneksel gıda üretimi ve pazarlama istekliliği. *Tekirdağ Zir. Fak. Derg.*, **14(3)**, 66-72.
- Ozden, A. (2008).** Yoğurdun Tarihi. *Güncel Gastroenteroloji*.12(2):128-133.
- Pederson, C.S. (1979)** In *Microbiology of Food Fermentation*, 2nd Edition, AVI, Connecticut, pp.1–29.
- Ray, R. C., & Montet, D. (2017).** *Fermented Foods, Part II: Technological Interventions*. CRC Press.
- Sacak, E.(2022). *Geleneksel Burdur Kökez Süzme Yoğurdunun Depolama Süresince Kalite Özelliklerinin Belirlenmesi*.Burdur Mehmet Akif Ersoy Üniversitesi Sağlık Bilimleri Enstitüsü, Yüksek Lisans tezi 176s.
- Sarısakal, B. (2018).** Silivri yoğurthaneleri. *Toplumsal Tarih*.14-18
- Tamime, A.Y., & Robinson, R.K. (2000).** *Yoghurt Science and Technology*.2<sup>th</sup> Edition pp.600. Published in North and South America by CRC Press LLC.
- Tekelioglu, Y., 2021. Coğrafi İşaretlerin a,b,c’si. *YÜciDERGİ*, 2:14-32.
- TGK (Türk Gıda Kodeksi) (2009).** Fermente Süt Ürünleri Tebliği (Tebliğ No:2009/25). Resmi Gazete Sayı: 27143, 16.02.2009, Ankara
- TURKPATENT, (2021). Türkiye’nin Dijital Cİ Platformu, Veritabanı ve İstatistik, <https://www.ci.gov.tr/ veri-tabani> (Erişim Tarihi:22.11.2022).

TURKPATENT, (2022). Silivri yoğurdu CÍ Tescil Belgesi (Tescil No:1180),<https://www.ci.gov.tr/>

(Erişim Tarihi:22.11.2022)

**USK. (2021).** <https://ulusalsutkonseyi.org.tr/wp-content/uploads/2021-Sut-Raporu.pdf>. (Erişim Tarihi:22.11.2022).

**Unsal, A. (2007).** “*Silivrim Kaymak*” *Türkiye'nin Yoğurtları*. İstanbul: Yapı Kredi Yayınları, 13-61.

**Vasilopoulou E, Dilis V, Soukara S, Trichopolilou A (2005).** “*The Systematic Inventigation of Traditional Foods in Europe*”. 1. International Food and Nutrition Congress. TÜBİTAK, June-15, İstanbul.

**Weerathilake, W. A. D. V., Rasika, D. M. D., Ruwanmali, J. K. U., & Munasinghe, M. A. D. D. (2014).** The evolution, processing, varieties and health benefits of yogurt. *International Journal of Scientific and Research Publications*, 4(4), 1-10.

**Yaygın H (1999).** *Yoğurt Teknolojisi*. Antalya: Akdeniz Üniversitesi Basımevi, s:44-331.

**Yerasimos M.2011.** *Evliya Çelebi Seyahatnâmesi'nde Yemek Kültürü*. İstanbul: Kitap Yayınevi, 503-504.

**Yurdakök, M. (2013).** Yoğurdun Öyküsü, Probiyotiklerin Tarihi, *Çocuk Sağlığı ve Hastalıkları Dergisi*; 56: 43-60.

**Yusuf, K.H.(1983).** *Wisdom of Royal Glory (Kutadgu Bilig): A Turko-Islamic Mirror for Princes*, translated with an introduction and notes by Robert Dankoff. Chicago: University of Chicago Press.



## **CHAPTER 6**

### **FROM CLIMATE CHANGE ADAPTATION STRATEGIES; ORGANIC FARMING**

*Sevinç BAŞAY<sup>1</sup>*

---

<sup>1</sup> Doç. Dr., ORCID : 0000-0002-9466-1015 Bursa Uludag University, Faculty of Agriculture, Department of Horticulture, Bursa- Turkey.

## Introduction

Climate change refers to a significant change in climatic conditions that follow a certain course for long periods of time. Climate change; temperature, precipitation, humidity, sea level, amount of ice etc. It includes major changes in factors and how these changes affect life on earth. Global warming, cited as part of climate change, relates to the recently rising and continuing to rise global average temperatures near the earth's surface (Vural, 2018). The cause of climate change; activities such as fossil fuel use, deforestation, improper land use, agricultural activities and industrial processes. It is the excessive increase in the emissions of greenhouse gases such as carbon dioxide (CO<sub>2</sub>), methane (CH<sub>4</sub>), chlorofluorocarbon (CFC), ozone (O<sub>3</sub>), which are released as a result of these activities, which are human activities (Anonymous, 2018; Başoğlu et. al., 2013). In order to prevent the expected dangers of global climate change on the earth, international studies are carried out with the participation of both developed and developing countries. Various decisions and protocols are signed for the healthy continuation of the ecosystem. (Şanlı, 2017). As a result, the gradual warming of the atmosphere due to climatic changes; due to the melting glaciers and rising sea levels, changes in ecosystems, the increase in the number and frequency of extreme weather events, the increase in climate-related natural disasters such as floods, storms, hurricanes, and droughts are experienced (Bayraç et. al., 2016). The changing climate not only threatens food security, but also causes resource problems such as pollution, water, scarcity, soil degradation and erosion.<sup>1</sup>

The effects of extreme weather events on agricultural production in Turkey are increasing seriously and negatively. In the coming years, it is predicted that these effects will increase with the global climate change and the opportunities to reach safe food will decrease (Kadioğlu et. al., 2017).

Climate change is one of the biggest challenges of our time (Muller et. al., 2016). Climate change is the defining challenge for human progress and ecological welfare in the 21st century. Most of the detected increase in global average temperatures since the mid-20th century is due to the observed increase in greenhouse gas concentrations (Anonymous, 2008). One of the biggest warnings to food production worldwide is Climate change. Researchers estimate that the production of globally important crops has decreased. (Villanueva et. al., 2017). In the modern world, climate protection is an important issue. The concentration of naturally occurring greenhouse gases in the atmosphere has increased significantly, contributing to the greenhouse effect and the severity of global warming (Holka et. al., 2022).

Agriculture contributing to and affected by climate change must both adapt to the changes and offer mitigation options such as carbon storage

and reducing greenhouse gas emissions (Niggli et. al., 2008 ).

When comparing conventional farming with organic farming, organic farming offers a system that can reduce environmental impacts. The primary goal of organic farming is not (and should not be) climate change mitigation, but increasing the transition to organic farming can contribute to reducing greenhouse gas emissions (Ahad et. al., 2020).

One of the EU's goals in the fields of agriculture, food and biodiversity within the scope of the European Green Deal is; There is an urgent need to increase organic farming areas, improve animal welfare and reverse biodiversity loss. (Anonymous, 2021).

Look at in terms of its environmental effects and climate change; When processes such as the use of fossil fuels, fertilizers and pesticides in agriculture and food production, transportation and distribution of inputs and food from the production site to the user are included, the share of agricultural activities in greenhouse gas emissions is around 30%. However, agriculture based on ecological practices, emerges as a solution in terms of adaptation to climate change and reaching long-term goals. Ecological management models, on the one hand, reduce emissions, on the other hand, contribute to the climate crisis with increased carbon sequestration capacity (Aksoy, 2021). The aim of this study; It is an overview of the importance of climate change and the effects of organic agriculture on climate change.

### **Organic Agriculture**

Organic farming is an alternative production method, a system that avoids the use of fertilizers and synthetic pesticides, and relies on crop rotation, biological pest control, green manure and manure to maintain soil fertility (Goh, 2011). The most important feature of organic agriculture is that it tends to regain the nutrients and organic carbon necessary for the soil. Therefore, practices include direct recovery of animal manure, effective composting techniques for crop residues, and mixing crop waste with green manure to prevent erosion of the fertile topsoil. Improving soil structure with these methods helps to reduce greenhouse gas emissions (Aulakh et. al., 2022)

Nowadays, organic agriculture is developing rapidly, both in the European Union (EU) and globally (Figure 1). Total organic farming area, including certified area and converted area, has increased fivefold worldwide from 2000 to 2020, and nearly quadrupled in the EU. In the world, organic agriculture is practiced on around 75 million hectares of agricultural land in 2020 and constitutes approximately 1.5% of the total agricultural area (Holka et. al., 2022).

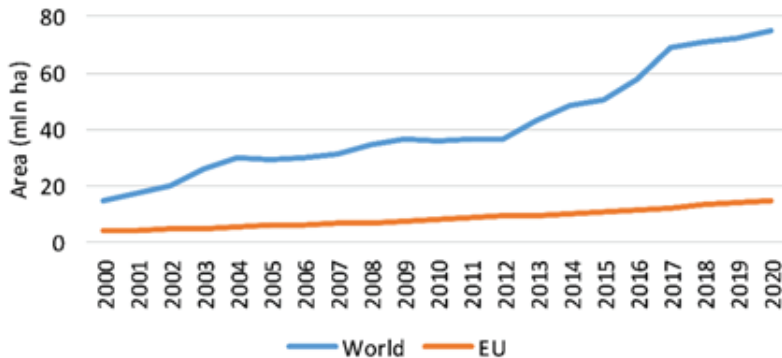

Figure 1. Organic agricultural land in the world and the European Union (EU) in the years 2000–2020. Source: Holka et. al., 2022.

Organic farming, especially in recent years, has started to be seen as a necessity with the development of environmental awareness. In recent years, many researchers and farmers have started to prefer regenerative organic farming practices instead of traditional farming (Demirel et. al., 2015).

### **The Impact of Organic Agriculture on Climate Change**

Organic agriculture, which largely excludes the use of agricultural chemicals such as chemical plant protection products and mineral fertilizers, relies primarily on other natural methods to increase or maintain the biological activity of the soil, appropriate crop rotation, as well as the selection of appropriate plant species and varieties. While providing high-quality food production, it preserves biodiversity and helps maintain soil fertility by reducing environmental pollution with chemicals (Holka et. al., 2022). Research studies have shown that organic soils tend to score higher than conventional soils when it comes to soil health measures. For example, organic soils have greater soil stability, more biological activity, higher diversity, and more biomass than conventionally soils. (Shade et. al., 2020).

Chemical pesticides produced using fossil fuels are not used in organic agriculture, thus reducing greenhouse gas emissions. According to 30 years of applied and comparative research from the Rodale Institute, organic farming uses 45% less energy than conventional farming. Many methods used in organic farming (crop rotation, nitrogen-fixing legumes) return more carbon to the soil, increase productivity, and store carbon. Organic agriculture plays important role in reducing greenhouse gas emissions thanks to the carbon sequestration and storage capacity of the soil (Anonymous, 2016). Scialabba et. al., (2010) said that discussed the adaptability and mitigation power of organic farming systems with three main

feature aspects: cropland management, grassland and livestock management, and farming system design. An important contribution of organically managed systems to climate change mitigation has been identified in the careful management of nutrients and therefore in reducing N<sub>2</sub>O emissions from the soil. Many common practices of organic farming help to improve soil quality and fertility and contribute significantly to higher soil organic carbon sequestration compared to land under conventional management (Figure 2) (IFOAMEU 2022.)

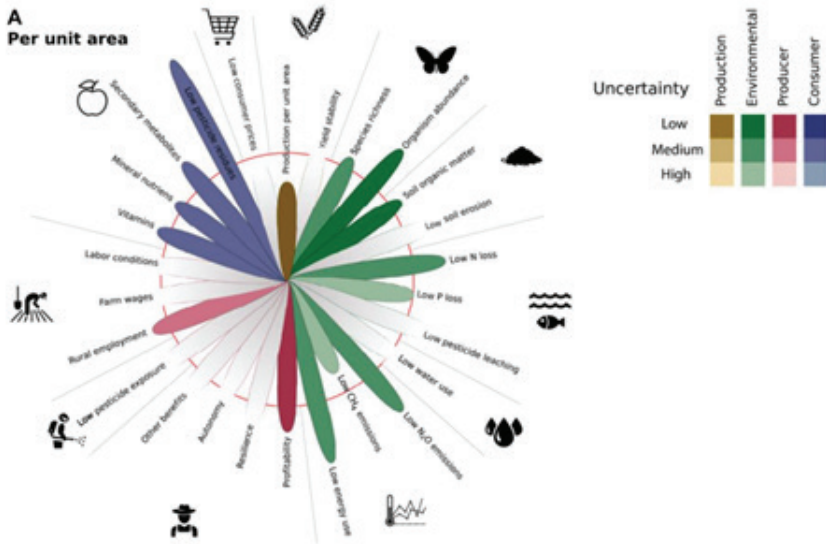

Figure 2. Average performance per unit area of organic farming relative to conventional farming (indicated by red circle; larger leaves represent superior organic performance) Source: Seufert and Ramankutty (2017).

Sardiana (2020) said that organic agriculture, which helps reduce global warming by improving carbon sequestration, is a production method that promotes sustainability. With leguminous crops commonly used in organic farming, many farming practices such as rotation, minimal tillage, and crop residue recycling support increasing soil carbon sequestration and reducing greenhouse gases (Goh, 2011).

Since most of synthetic pesticides and fossil fuel-based fertilizers are banned in organic farming, it has a significantly lower carbon footprint. The production of these farm chemicals is energy intensive. Soil-boosting practices that are the foundation of organic farming also help to capture more carbon in the soil compared to non-organic systems (Brook, 2022). Organic farming is believed to have the potential to help increase soil fertility, reduce carbon emissions and improve climate resilience (Wekeza et al., 2022). Clark (2020) He argues that the

all-or-nothing proposition of organic farming against climate change is potentially misleading and distracting, instead, site-specific assessments argue that it will provide a better understanding of where organic production is more appropriate and effective at addressing greenhouse gas emissions. Yodkhum et. al. states that a fair comparison between conventional and organic paddy farming clearly shows that the greenhouse gas emissions of conventional paddy rice are significantly higher than that of organic paddy farming. Likewise, Skinner et al. state that greenhouse gas emissions in conventional farms are much higher than in organic farms (Wekeza et. al., 2022).

In his study, the perceptions and adaptations of conventional and organic farmers to climate change and the factors affecting such decisions were examined. To reduce the impacts of climate change on vegetable farming, both organic farmers and conventional implement various adaptation strategies. The strategies include using superior varieties, implementing crop rotation, implementing mixed cropping, adjusting planting, growing nonwater-intensive crops, increasing the use of organic manure, irrigation using shade, using mulch techniques (Irham, et. al., 2022).

### **Conclusion**

Organic agriculture can be considered as a strategy to increase the capacity to adapt to climate change risk. Organic farmers are on the advantageous side in this harmony (in terms of knowing the path followed in organic farming). Revitalizing the adaptation capacity of the farmers should be the primary goal of the provincial and district directorates of agriculture and local administrations. While many researchers have a positive view of the impact of organic agriculture on climate change, some researchers hesitantly look at the impact of climate change due to the fact that the yield per unit area is lower than conventional production. All in all, organic agriculture, when applied correctly, can be a part of the solution, It is one of the strategies to combat climate change with its aspects of reducing greenhouse gas emissions and storing large amounts of carbon.

## References

- Ahad, L., Mir, R. A. 2020. Organic Farming In Resilience With Climate Change. European Journal of Molecular & Clinical Medicine ISSN 2515-8260 Volume 07, Issue 10.
- Aksoy, U. 2021. Organik Tarım: İklim krizine karşı en güçlü kozumuz. <https://www.bugday.org/blog/organik-tarim-iklim-krizine-karsi-en-guclu-kozumuz/>
- Anonim, 2008. Climate change: the challenges for agriculture. European Commission Directorate-General for Agriculture and Rural Development. Rue de la Loi 200, B-1049 Brussels Belgium. s. 19
- Anonim, 2016. Organik Tarım Uzun Vadede Sürdürülebilirliği Sağlar. [https://www.gaporganik.org/uploaded\\_files/dosyaKayit/170105162503\\_kkk.pdf](https://www.gaporganik.org/uploaded_files/dosyaKayit/170105162503_kkk.pdf) Erişim tarihi: 03.12.2022.
- Anonim 2018. Küresel Isınma Ve İklim Değişikliği. <https://iklim.deu.edu.tr/> Erişim tarihi:03.12.2022
- Anonim 2021. Yeşil Mutabakat Eylem Planı 2021. <https://ticaret.gov.tr/data/60f1200013b876eb28421b23/MUTABAKAT%20YE%C5%9E%C4%B0L.pdf> Erişim tarihi: 03.12.2022
- Aulakh, C. S., Sharma, S., Thakur, M., Kaur, P. 2022. A review of the influences of organic farming on soil quality,crop productivity and produce quality. Journal Of Plant Nutrition2022, Vol. 45, No. 12, 1884–1905
- Başoğlu, A., Telatar, O.M.2013. İklim Değişikliği'nin Etkileri: Tarım Sektörü Üzerine Ekonometrik Bir Uygulama. KTÜ-Sosyal Bilimler Enstitüsü, Sosyal Bilimler Dergisi, 6, s.7-25.
- Bayraç, H.N., Doğan, E. 2016. Türkiye'de İklim Değişikliğinin Tarım Sektörü Üzerine Etkileri. Eskişehir Osmangazi Üniversitesi İibf Dergisi, Nisan 2016, 11(1), 23- 48.
- Brook, N. 2022. Organic Agriculture Helps Solve Climate Change. Expert Blog. <https://www.nrdc.org/experts/lena-brook/organic-agriculture-helps-solve-climate-change>
- Clark, S. 2020. Organic Farming and Climate Change: The Need for Innovation. Sustainability 2020, 12, 7012.
- Demir, S., Demir, F. 2015. Yenileyici Organik Tarım Ve Küresel İklim Değişikliği. Doğu Karadeniz Iı. Organik Tarım Kongresi 6-9 Ekim 2015, Pazar/Rize.
- Goh, K.M. 2011. Greater Mitigation Of Climate Change By Organic Than Conventional Agriculture: A Review. Biological Agriculture & Horticulture. 27(2), P. 205-229.
- Holka, M.; Kowalska, J.; Jakubowska, M. Reducing Carbon Footprint of Agriculture. Can Organic Farming Help to Mitigate Climate Change? Agriculture 2022, 12, 1383. <https://doi.org/10.3390/agriculture12091383>

- IFOAMEU 2022. Organic agriculture and its benefits for climate and biodiversity. [https://www.organicseurope.bio/content/uploads/2022/04/IFOAMEU\\_advocacy\\_organic-benefits-for-climate-and-biodiversity\\_2022.pdf?dd](https://www.organicseurope.bio/content/uploads/2022/04/IFOAMEU_advocacy_organic-benefits-for-climate-and-biodiversity_2022.pdf?dd)
- Irham, I., Fachrista, I.A., Masyhuri, M., Suryantini, A. 2022. Climate Change Adaptation Strategies by Indonesian Vegetable Farmers: Comparative Study of Organic and Conventional Farmers. *ScientificWorldJournal*. 2022; 2022: 3590769.
- Kadioğlu, M., Ünal, Y., İlhan, A., Yürük, C. 2017. Türkiye ‘De İklim Değişikliği Ve Sürdürülebilirlik. Türkiye Gıda ve İçecek Sanayii Dernekleri Federasyonu. s.86.
- Muller, A., Bautze, L., Meier, M., Gattinger, A., Gall, E., Chatzinikolaou, E., Meredith, S., Ukas, T., Ullmann, L. 2016. Organic Farming, Climate Change Mitigation And Beyond. IFOAM EU Rue du Commerce 124, BE - 1000 Brussels, Belgium s.72.
- Niggli, U., Schmid, H., Fliessbach, A. 2008. Organic Farming and Climate Change. International Trade Centre UNCTAD/WTO Research Institute of Organic Agriculture (FiBL) s. 39.
- Sardiana, I.K. 2020. Organic vegetable farming system enhancing soil carbon sequestration in Bali, Indonesia. The 5th International Conference on Climate Change 2020.
- Seufert, V. and Ramankutty, N., 2017. Many shades of gray —The context-dependent performance of organic agriculture. *Science advances*, 3(3), 1602638.
- Scialabba, N.E.H., Muller-Lindenlauf, M. 2010. Organic agriculture and climate change. *Renewable Agriculture and food systems*. V.25 (2), p.158-169.
- Shade, J., Tully, K. 2020. Organic Farming Practices for Improving Soil Health. The Organic Center. [https://www.organic-center.org/sites/default/files/project/2020/03/soil-health-review\\_shadetully.pdf](https://www.organic-center.org/sites/default/files/project/2020/03/soil-health-review_shadetully.pdf)
- Şanlı, B., Bayrakdar, S., İncekara, B. 2017. Küresel İklim Değişikliğinin Etkileri Ve Bu Etkileri Önlemeye Yönelik Uluslararası Girişimler. *Süleyman Demirel Üniversitesi İktisadi ve İdari Bilimler Fakültesi Dergisi* Y.2017, C.22, S.1, s.201-212.
- Villanueva, A.B., Halewood, M., Noriega, I. L. 2017. Agricultural Biodiversity in Climate Change Adaptation Planning. *European Journal of Sustainable Development* (2017), 6, 2, 1-8.
- Vural, Ç. 2018. Küresel İklim Değişikliği Ve Güvenlik. *Güvenlik Bilimleri Dergisi*, Mayıs 2018, 7 (1), 57 – 85.
- Wekeza, S.V.; Sibanda, M.; Nhundu, K. Prospects for Organic Farming in Coping with Climate Change and Enhancing Food Security in Southern Africa: A Systematic Literature Review. *Sustainability* 2022, 14, 13489. <https://doi.org/10.3390/su142013489>.



## **CHAPTER 7**

### **A REVIEW OF UTILIZATION OF LAMINARIN, ALGINATE, AND FUCOIDAN POLYSACCHARIDES FROM MACROALGAE FOR PROMOTING GROWTH PERFORMANCE AND HEALTH IN AQUATIC ORGANISMS**

*Metin YAZICI<sup>1</sup>, Mehmet NAZ<sup>2</sup>, Yavuz MAZLUM<sup>3</sup>*

---

1 Asistant Prof. Iskenderun Technical University, Faculty of Marine Science and Technology, Department of Aquaculture, IskenderunHatay, Turkey, E-mail: [metin.yazici@iste.edu.tr](mailto:metin.yazici@iste.edu.tr) , ORCID ID: <https://orcid.org/0000-0002-7011-886X>

2 Associate Prof. Dr. Iskenderun Technical University, Faculty of Marine Science and Technology, Department of Aquaculture, Iskenderun-Hatay, Turkey, E-mail: [mehmet.naz@iste.edu.tr](mailto:mehmet.naz@iste.edu.tr) , ORCID ID: <https://orcid.org/0000-0002-5129-8498>

3 Prof. Dr. Iskenderun Technical University, Faculty of Marine Science and Technology, Department of Aquaculture, Iskenderun Hatay, Turkey, E-mail: [yavuz.mazlum@iste.edu.tr](mailto:yavuz.mazlum@iste.edu.tr) ORCID ID: <https://orcid.org/0000-0002-9547-0966>

## Introduction

Aquaculture is one of the fastest-growing and promising nutrition-based industries in the world. However, annual costs of up to 6 billion dollars due to infectious diseases and increasing fishmeal prices negatively affect the development of aquaculture (Thepot et al., 2021). In addition, antibiotics, which have been used for many years in the fight against diseases, carry the risk of harming the fish, the environment, and humans as the final consumer (Quezada-Rodriguez et al., 2017). For this reason, studies on the availability of functional feed additives that allow less use of fish meals as well as in the fight against diseases have gained importance (Mohan et al., 2019; Patel et al., 2022).

In fact, the basic nutritional requirements of the target species must be met in order to increase growth and feed efficiency in fish and crustaceans (Encarnaçao et al., 2016). In addition, a wide variety of natural functional feed additives such as prebiotics, probiotics, medicinal and aromatic plants, and macroalgae are used to support the health and stress resistance of animals (Raguraman et al., 2020; Saeed et al., 2021; Vijayaram et al., 2022).

Marine macroalgae are considered excellent candidates for use as health-promoting ingredients in aquaculture because of its balanced nutritional value and abundance of bioactive compounds. Therefore, macroalgae have an increasing use in aquaculture, both raw and with their extraction products such as polysaccharides (Kraan et al., 2022; Mazlum et al., 2022). Indeed, the use of polysaccharides has gained great interest in recent years due to their biodegradability, biocompatibility, non-toxicity, and several specific therapeutic activities for different new applications (Vidhya et al., 2019).

The current study was aimed to evaluate the recent studies on the effects of polysaccharides obtained from brown algae, one of the most important macroalgae groups, on growth performance and health in aquaculture.

### Macroalgae and Polysaccharides:

Macroalgae play an important role as a primary producer on sea coasts, produces about half of the organic matter in the world (Vidhya et al., 2019; Moreira et al., 2022). Marine macroalgae are divided into 3 main groups according to their photosynthetic pigment content, cell wall components, carbohydrate reserves, and flagella structures; Chlorophyta (green), Rhodophyta (red), and Ochrophyta (brown) (Pereira, 2021).

Red macroalgae (7300) constituted the highest group based on species detected so far, followed by Brown macroalgae (2000) and green macroalgae (1500), respectively (Moreira et al., 2022). The production amount of marine macroalgae have shown significant changes over the years (Table 1).

**Table 1.** *Change in production amounts in marine macroalgae between 1950-2019 (FAO, 2022).*

Macroalgae groups	1950 (tonnes)	2019 (tonnes)	(2019) share of total (%)	(1950-2019) Change* (fold)
Brown	13000	16.400.000	47.3	1261.54
Red	21000	18.300.000	52.6	871.43
Green	14019	16.669	0.05	1.19

\*The amount of development that occurred between 1950 and 2019 was multiplied.

Macroalgae produce structurally unique molecules such as polysaccharides to survive in stressful environmental conditions. (Jiang et al., 2021; Tziveleka et al., 2021). Therefore, Macroalgae have significant potential to be used as functional food ingredients or nutrients (Vidhya et al., 2019).

Marine macroalgae are one of the most important sources of producing economically important polysaccharides with bioactive properties and serve as an important source of dietary fibers (Vidhya et al., 2019; Jiang et al., 2021). Algal polysaccharides have promising applications in many different fields in parallel with their wide variety of structural diversity (Anisha et al., 2022). In recent years, significant increases have been observed in studies with the results obtained from aquaculture practices and compatible with the developing blue economy perspective (Naiel et al., 2021; Anisha et al., 2022). These studies demonstrated the fascinating effects of adding polysaccharides to the diet of aquatic organisms on growth, immunity, and fish welfare (Sony et al., 2020).

### **Polysaccharides derived from Brown macroalgae:**

Brown seaweed contains abundant polysaccharides such as laminarin, fucoidan, and alginate (Yin et al., 2014; Jiang et al., 2021). Polysaccharides derived from brown algae have exhibited beneficial biological activities on human and animal nutrition and health, so they have attracted worldwide attention. These biological activities of polysaccharides may vary depending on the geographical location where macroalgae are collected, the harvest season, and the extraction methods (Abdel-Latif et al., 2022; Anisha et al., 2022; Bakky et al., 2022). It is considered that polysaccharides may exert growth and health-promoting effects by acting as a prebiotic (Vidhya et al., 2019).

### **Laminarin:**

Laminarin is obtained mainly in the fronds of Laminaria. Although the content of laminarin varies according to the season and habitat, it can reach up to 32% of the dry weight (Jiang et al., 2021). It has been suggested that laminarin can be used as a functional food supplement due to its properties such as strengthening the immune system and lowering cholesterol levels in the serum (Yin et al., 2014; Morales-Lange et al., 2015).

The effects of laminarins on several fish species have been evaluated in aquaculture (Table 2). Promising results have been obtained from the use of Laminarin as a feed additive in aquaculture (Jiang et al., 2021). Jianbin et al. (2017) reported that the addition of 0.6% laminarin provided approximately 30% more weight gain in PearlGentian Grouper (*Epinephelus fuscoguttatus* ♀ × *E. lanceolatus* ♂) compared to the group without laminarin, a 15% decrease in feed conversion rate, and an increase in immune parameters such as Alkaline phosphatase and Lysozyme.

In another study with Grouper fish (*Epinephelus coioides*), it was suggested that the growth performance and feed efficiency of laminarin increased with the addition of 0.5%, however, this effect was weaker at higher doses (1.0% or 1.5%) (Yin et al., 2014). Yin et al. (2014) have shown that Laminarin not only increases immune parameters such as total protein and lysozyme, but also strengthens the antioxidant defense system.

Considering the effect of laminarin to modulate the immune response and stimulate the growth of fish, Yin et al. (2014) stated that laminarin can be used as a feed additive to promote growth and increase immunity in groupers.

Researchers also suggest that polysaccharides will contribute to reducing the need for antibiotic use due to their immunostimulating effects and consequently increased disease resistance (Yin et al., 2014).

Polysaccharides are given to the fish by injection as well as by adding to the feed. Cellular immune responses to laminarin of rainbow trout (*Oncorhynchus mykiss*) have been reported to result in increased phagocytic activity in head kidney macrophages of both laminarin-injected and laminarin-fed fish (Morales-Lange et al., 2015).

However, due to factors such as animal welfare, ease of administration and inability to apply to fish of all sizes, alternatives to the injection method are being researched and the oral delivery comes to the fore (Yazici and Candan, 2006).

The immune-enhancing and growth-promoting effects of laminarin have also been recently proven in studies with *Ictalurus punctatus* (Jiang

et al., 2021). Jiang et al. (2021) found significant increases in the expression of the TLR5 gene, which acts as a bridge between the nonspecific and specific immune systems. Therefore, it has been suggested that laminarin may be an important tool in the enhancement of both specific and non-specific immunity. This provides a significant contribution to the fight against the disease and the survival rate of the fish.

Moreover, Jiang et al. (2021) suggested that laminarin improves the physical quality of *Ictalurus punctatus* and increases its productivity, offering great potential for application in the aquaculture sector.

**Table 2.** Applications of laminarin polysaccharide to some cultivated aquatic species

Aquatic species	Duration	Doses	Growth	Immunity	R. Dose	Ref.
<i>E. coioides</i>	48 days	5-10-15 g kg <sup>-1</sup>	↑	↑	NS	1
<i>O. mykiss</i>	21 days	0.2-0.8 g kg <sup>-1</sup>	ND	↑	NS	2
<i>E. fuscoguttatus</i> ♀ × <i>E. lanceolatus</i> ♂	66 days	0.6%	↑	↑	0.6%	3
<i>I. punctatus</i>	45 days	1-2-4-8 g kg <sup>-1</sup>	↑	↑	NS	4

Note: Duration: Trial period; up arrow (↑) represents significant increase; ND: Not detected; R.dose: Recommended dose; NS: Not suggested; Ref.:References 1:Yin et al., 2014; 2: Morales-Lange et al., 2015; 3: Jianbin et al., 2017; 4:Jiang et al., 2021

**Alginate:**

Alginate is a polysaccharide obtained from salts of alginic acid in brown algae. Alginates have been shown to have antibacterial and antioxidant properties. Studies on the use of alginate in aquaculture are shown in Table 3. It has been suggested that low molecular weight sodium alginates (LMW-SA) obtained from brown marine macroalgae have prebiotic properties and have immune system and growth performance-enhancing effects (Doan et al., 2016).

Recently, many studies have investigated the effects of prebiotics on aquatic organisms, including improving growth performance, stimulating immunity, increasing disease resistance, and modulating the gut microbiota (Doan et al., 2018; Nedaei et al., 2019; Yazici et al., 2021; Yazici et al., 2022).

Since tilapia is one of the most produced fish species, studies have been conducted to investigate the effectiveness of many different polysaccharides (Kari et al., 2022). In this context, it has been reported that alginate changes the intestinal microbiota in tilapia, making the fish more resistant to diseases. Therefore, studies on the use of alginates in aquaculture, both individually

and symbiotically with probiotics, have been the focus of attention (Doan et al., 2016; Vidhya et al., 2019).

Doan et al. (2016) reported that significant increases were observed in growth performance and in non-specific immune parameters such as serum lysozyme, phagocytic, respiratory burst, and complement activity when they applied alginate (LMSWA) to feed in Nile tilapia. Doan et al. (2016) also showed that combined administration of alginate with a probiotic produced more effective results on fish.

Promising results were obtained in studies investigating the effects of alginates on Pacific white shrimp (*Litopenaeus vannamei*) (Yudiati et al., 2016; Santos et al., 2019; Chen et al., 2021). Alginate polysaccharide extracted from *Sargassum siliquosum* caused an increase in both non-specific immunity and immune-related gene expressions of Pacific white shrimp (Yudiati et al., 2016).

In another study with Pacific white shrimp, cottonseed protein concentrate was used as a substitute for fish meal. In this study, it was reported that the use of alginate with a rate of 1.91% showed a prebiotic effect and increased growth performance, non-specific immunity, and disease resistance. It has been reported that the addition of alginate to the feed allows the use of fishmeal at a low rate in white shrimp (Chen et al., 2021).

Santos et al. (2019) have also shown that oral administration of sodium alginate can be used as an effective, simple, and economically viable immunostimulant with the potential to contribute to the development of the shrimp industry. Santos et al. (2019) have evaluated that the best growth performance is obtained when 0.2-0.4g kg<sup>-1</sup> sodium alginate is added to shrimp diets.

Santos et al. (2019) suggested that the increase in immune ability and resistance of penaeid shrimp fed sodium alginate may be due to the regulation of non-specific pathogen receptors. Because, in the study, they detected up-regulation of Toll-receptor genes (TLR), which plays an important role in the innate immunity of *L. vannamei*, in the groups fed with sodium alginate-added diets.

Santos et al. (2019) concluded that the upregulation of TLR genes can increase pathogen recognition as well as pathogen resistance. Moreover, Santos et al. (2019) also reported that this assumption was proven by the 100% survival of *L. vannamei* fed sodium alginate infected with LC50 *Vibrio alginolyticus*.

Neamat-Allah (2019) also reported that when low molecular weight sodium alginate is used at a rate of 3% in African catfish (*Clarias gariepinus*), an increase in growth performance, an improvement in immune

defense and development of resistance against *Aeromonas hydrophila* bacteria are obtained. Considering these features, Neamat-Allah et al. (2019) suggested that LMWSA could be used in aquaculture as a new prebiotic.

It has also been proven in other studies that sodium alginate has a prebiotic effect on aquatic organisms (Asaduzzaman et al., 2019; Ashouri et al., 2020).

Dietary sodium alginate supplementation has also been shown in slow-growing fish to improve the physiological and immunological responses of fish. Asaduzzaman et al. (2019) suggested that 0.2-0.4% Sodium alginate supplementation in Malaysian slow-growing *Tor tombroides* fish increased growth performance, feed utilization as well as growth-related gene expression. Asaduzzaman et al. (2019) suggested that although the mechanism of increasing the growth performance of sodium alginate is not fully known, it may be due to its prebiotic characteristic.

Because, Asaduzzaman (2020) proved in his study that Sodium alginate, which can be easily fermented by bacteria in the intestine, also regulates the intestinal microbiota. As a result, better digestion process, feed conversion, and growth performance can be achieved.

Ashouri et al. (2020) obtained promising results as a functional feed additive in Asian sea bass by using alginate in the form of LMWS and together with the probiotic *Pediococcus acidilactici*.

In this context, Ashouri et al. (2020) reported that when alginate in the form of LMWS was used alone or with probiotic bacteria at the rate of 5g kg<sup>-1</sup>, it increased growth performance and improved intestinal morphology and digestive enzyme activities, as well as strengthened antioxidant defense in Asian sea bass fry. Ashouri et al. (2020) suggested that this form of alginate could be a new prebiotic candidate due to its higher solubility and fermenting properties. Indeed, they suggested that alginate can be used as a functional feed additive in Asian sea bass because it showed promising results when used in LMWS form and together with *Pediococcus acidilactici* probiotic.

Alginates can be depolymerized to obtain oligosaccharide forms. When alginates are used as a feed additive in aquaculture in the form of oligosaccharides, it has been found to increase growth performance, improve fat metabolism and strengthen antioxidant defense in grass carp (*Ctenopharyngodon idellus*) (Yang et al., 2021). Therefore, it has been stated that its use as a feed additive in grass carp cultivation may be beneficial (Yang et al., 2021).

As a result, the use of nutrition particularly polysaccharides from various marine sources in boosting the immune response of fish and shrimp

in this way has recently gained tremendous momentum in the commercial aquaculture industry (Sony et al., 2020).

Since it has been shown that sodium alginate can be used as a potential immunostimulant in fish and shrimp, it would be beneficial to examine its effects on disease resistance against a particular pathogen and immune-related genes in future research (Asaduzzaman et al., 2019).

**Table 3.** Applications of alginate polysaccharide to some cultivated aquatic species

Aquatic species	Duration	Doses	Growth	Immunity	R. Dose	Ref.
<i>O. niloticus</i>	60 days	10 gkg <sup>-1</sup> with probiotic	↑	↑	NS	1
<i>T. tambroides</i>	60 days	0.1-0.2-0.4-0.8%	↑	↑	0.2–0.4%	2
<i>C. gariepinus</i>	56 days	1-3%	↑	↑	1-3%	3
<i>L. calcarifer</i>	42 days	5-10 gkg <sup>-1</sup> with probiotic	↑	↑	5gkg <sup>-1</sup> with probiotic	4
<i>C. idellus</i>	42 days	5-10-20 gkg <sup>-1</sup>	↑	ND	NS	5
<i>L.vannamei</i>	15 days	1-2 gkg <sup>-1</sup>	ND	↑	2 gkg <sup>-1</sup>	6
<i>L.vannamei</i>	60 days	0.2-0.4-0.6-0.8 gkg <sup>-1</sup>	↑	↑	0.2-0.4 gkg <sup>-1</sup>	7
<i>L.vannamei</i>	56 days	10-20-30-40 gkg <sup>-1</sup>	↑	↑	1.91%	8

Note: Duration: Trial period; up arrow (↑) represents significant increase; ND: Not detected; R.dose: Recommended dose; NS: Not suggested; Ref.:References 1: Doan et al., 2016; 2:Asaduzzaman et al., 2019; 3:Nemat-Allah et al., 2019; 4: Ashouri et al., 2020; 4: Yang et al., 2021; 6:Yudiati et al., 2016; 7:Santos et al., 2019; 8: Chen et al., 2021.

### Fucoidan:

Fucoidan is a polysaccharide naturally found on the cell walls of brown macroalgae, but is also found in some sea invertebrates, such as sea cucumber and Sea Urchins (Mir et al., 2018; Sony et al., 2019). Brown seaweeds such as Ecklonia, Ascophyllum, Cladosiphons, Undaria, Saccharina, Sargassum, Laminaria and Fucus are the richest sources of fucoidan (Anisha et al., 2022). Fucoidan is considered as immunostimulating agents, similar to some polysaccharides such as β-glucan, lipo-polysaccharide (LPS) and peptidoglycan produced by microorganisms, and alginate, carrageenan and laminarin obtained from macroalgae (Sivagnanavelmurugan et al., 2014).

It has been one of the most studied macroalgal polysaccharides as a feed ingredient in aquaculture, due to its unique bioactive properties such as immune modulation, anti-inflammatory, antioxidant, disease resistance, and growth stimulation (Sivagnanavelmurugan et al., 2014; Gora et al., 2018; Cui et al., 2020; Sony et al., 2019). Table 4 shows some studies using fucoidan in aquaculture.

Prabu et al. (2016) suggested that the immune system was activated when catfish (*Pangasianodon hypophthalmu*) were fed with 2% fucoidan-enriched feed, and a higher survival rate was observed when challenged with *A. hydrophila*.

Mir et al. (2017) reported that when Fucoidan was used together with methionine in *L. rohita*, an improvement was observed in growth parameters such as SGR, weight gain, and FCR. It was also stated that the highest protection was obtained when experimentally infected with *Aeromonas hydrophila*. Moreover, in this study, phagocytic activity was increased in fish fed with fucoidan-containing feed.

Therefore, Mir et al. (2017) suggested that co-supplementation of lower doses of methionine with 2% Fucoidan could synergistically enhance growth performance as well as the non-specific immune response of *L. rohita*.

However, another study by Gora et al. (2018) concluded that 2% dietary fucoidan did not show any growth-promoting effect in *L. rohita* but could be a potential immunostimulant.

Sony et al. (2019) stated that the addition of Fucoidan at the optimum level (0.3-0.4%) in juvenile red sea bream (*Pagrus major*) provides improved growth performance and in health-related parameters such as non-specific immunity, hematological parameters, and antioxidant defense. Sony et al. (2019) evaluated that utilizing feed in nutritional groups with Fucoidan has increased. They suggested that this may be the cause of an increase in growth performance in fish fed with Fucoidan.

Cui et al. (2020) reported that growth performance and intestinal immunity were improved when 30g kg<sup>-1</sup> of pure fucoidan-supplemented feed was used in gibel carp (*Carassius auratus gibelio*). Therefore, they stated that the use of fucoidan may contribute to the protection of intestinal mucus health of gibel carp and indirectly to the prevention of pathogen infections.

As a promising feed additive, Fucoidan dietary application can also be used as a potential feed additive for aquaculture production, as it has a protective effect against tissue damage as well as improving growth, intestinal health, and antioxidant status in Nile tilapia (Mahgoub et al. 2020).

Cui et al. (2020) suggested that the growth performance and intestinal health-improving effect of fucoidan supplementation are due to the increase in

the activities of intestinal digestive enzymes and modulation of the intestinal microbiota as a result of treatment with fucoidan.

It has been stated that the use of fucoidan allows the use of cheaper protein sources as an alternative to fish meal (Sony et al., 2020). In the diets of red sea bream, an alternative protein source to fish meal up to 75% was used without any problems, by using 0.4% fucoidan together with methionine and lysine amino acids (Sony et al., 2020). Sony (2020) claimed in the study that fucoidan increased the effectiveness of the use of Soy protein isolate, which was used as a fish meal substitute, and showed positive effects on the growth performance and health of fish. These effects of fucoidan have been attributed to its power to influence the fish gut microbiota.

It has been stated that fucoidan can be used to reduce or neutralize the harmful effects of harmful toxic substances for some fish. For instance, Abdel-Warith (2021) showed that fucoidan plays an important role in eliminating the harmful effect of Atrazine toxic substance in Nile tilapia. This effect of fucoidan has been attributed to its potential to increase gut health and digestive capacity.

Fucoidan has been widely applied in recent years to enhance innate immunity against pathogens and improve growth performance in crustaceans, and impressive results have been obtained from these studies (Sivagnanavelmurugan et al., 2014; Salehpour et al., 2021).

It has been reported that the addition of 0.1% and 0.3% fucoidan extracted from *Sargassum wightii* resulted in increased growth performance, improved immunity, and increased disease resistance in *Penaeus monodon* (Sivagnanavelmurugan et al., 2014).

Sivagnanavelmurugan et al. (2014) reported that fucoidan added to the diets of *P. monodon* showed a significant increase in parameters such as weight gain and SGR, while an increase was also observed in all immune parameters such as THC, prophenoloxidase, respiratory burst, and phagocytic activity. Furthermore, in the same study, the addition of 0.1% and 0.3% of Fucoidan to the diet resulted in a reduction in mortality of up to 73% in *P. monodon* experimentally infected with *Vibrio parahaemolyticus*. Therefore, Sivagnanavelmurugan et al. (2014) suggested that Fucoidan could be used as a good food source to increase the growth of *P. monodon* and also as an alternative prophylactic agent to prevent *Vibrio* diseases.

The immunostimulating effect of fucoidan in shrimp has been attributed to the activation of a protein known to initiate and increase hemocyte phagocytic activity (Sivagnanavelmurugan et al., 2014).

It has been determined that Fucoidan plays an important role as a natural immunostimulant and feed additive for *L. vannamei*, the most im-

portant shrimp species cultivated. The incorporation of 0.4% Fucoidan derived from *Cystoseira trinodis* resulted in improvement in growth, immunity, and immune-related gene expression in *L. vannamei*. In addition, significant development of resistance to the virus was observed in shrimps challenged with WSSV (Salehpour et al., 2021).

Freshwater crayfish, another important group of aquatic organisms cultivated, are the largest invertebrates in freshwater environments. *Procambarus clarkii*, which is in this group, is considered to be the most important crayfish species grown worldwide today (Jin et al., 2021).

Jin et al. (2021) indicated that dietary fucoidan (30 mg kg<sup>-1</sup>) increased the innate immune response of crayfish, significantly increasing the survival rate after white spot syndrome virus (WSSV) infection, and could also reduce the copy number of WSSV. Therefore, it has been suggested that fucoidan can be used to improve the immune system in crayfish and to be used both as a preventative and therapeutic against WSSV Raguraman et al., 2020; Jin et al., 2021).

**Table 4.** Applications of fucoidan polysaccharide to some cultivated aquatic species

Aquatic species	Duration	Doses	Growth	Immunity	R. Dose	Ref.
<i>P. hypophthalmus</i>	45 days	1-2-3-6 %	ND	↑	2 %	1
<i>L. rohita</i>	60 days	1-2% with methionin	↑	↑	2%	2
<i>L. rohita</i>	60 days	1-2-3-6 %	↔	↑	0.2–0.4%	3
<i>P.major</i>	60 days	0.05-0.1-0.2-0.4-0.8%	↑	↑	0.3–0.4 %	4
<i>P.major</i>	56 days	0.4 %	↑	↑	NS	5
<i>C. auratus gibelio</i>	42 days	1-10-30 g kg <sup>-1</sup>	↑	↑	30 g kg <sup>-1</sup>	6
<i>O. niloticus</i>	30 days	1-2 mg kg <sup>-1</sup>	↑	↑	2 mg kg <sup>-1</sup>	7
<i>P. monodon</i>	60 days	0.1, 0.2-0.3%	↑	↑	NS	8
<i>L.vannamei</i>	60 days	0.1- 0.2-0.4%	↑	↑	0.4 %%	9
<i>P. clarkii</i>	7 days	20-30-40 mg kg <sup>-1</sup>	ND	↑	30 mg kg <sup>-1</sup>	10

Note:Duration: Trial period; up arrow (↑) represents significant increase; (↔) no significant changes; ND: Not detected; R.dose: Recommended dose; NS: Not suggested; Ref.:References 1: Prabu et al., 2016; 2:Mir et al., 2017; 3: Gora et al., 2018; 4: Sony et al., 2019; 5:Sony et al., 2020; 6: Cui et al., 2020; 7: Mahgoub et al., 2020; 8:Sivagnanavelmurugan et al., 2014; 9: Salehpour et al., 2021; 10: Jin et al., 2021

## **Conclusion and Future Perspective**

In this review, the potential of using polysaccharides obtained from brown algae in sustainable aquaculture was evaluated by analyzing the data of recent years. The study focuses on the effects of polysaccharides on the growth performance and health of aquatic organisms, which are the two most fundamental issues of aquaculture. The research revealed that algal polysaccharides could be used as a novel prebiotic in aquaculture. Polysaccharides have been evaluated to have the potential to improve growth and digestion, modulate the gut microbiota, strengthen the immune system, and provide resistance to disease in cultured aquatic organisms. These positive effects on aquatic organisms are thought to contribute significantly to sustainable aquaculture production.

When the studies were reviewed, it was evaluated that it is important to determine the optimal dose, otherwise the desired positive effects cannot be achieved.

In addition, it has been shown that algal polysaccharides are effective on animal physiology, allowing the use of different protein sources that can be used as a substitute for fish meal.

Considering all the obtained results, it could be suggested that polysaccharides obtained from brown algae have the potential to be used as functional feed additives in aquaculture.

## References:

- Abdel-Latif, H. M., Dawood, M. A., Alagawany, M., Faggio, C., Nowosad, J., & Kucharczyk, D. (2022). Health benefits and potential applications of fucoïdan (FCD) extracted from brown seaweeds in aquaculture: An updated review. *Fish & Shellfish Immunology*, 122, 115-130.
- Abdel-Warith, A. W. A., Younis, E. M., Al-Asgah, N. A., Gewaily, M. S., El-Tonoby, S. M., & Dawood, M. A. (2021). Role of fucoïdan on the growth behavior and blood metabolites and toxic effects of atrazine in Nile tilapia *Oreochromis niloticus* (Linnaeus, 1758). *Animals*, 11(5), 1448.
- Anisha, G. S., Padmakumari, S., Patel, A. K., Pandey, A., & Singhania, R. R. (2022). Fucoïdan from Marine Macroalgae: Biological Actions and Applications in Regenerative Medicine, Drug Delivery Systems and Food Industry. *Bioengineering*, 9(9), 472.
- Asaduzzaman, M., Iehata, S., Moudud Islam, M., Kader, M. A., Ambok Bolong, A. M., Ikeda, D., & Kinoshita, S. (2019). Sodium alginate supplementation modulates gut microbiota, health parameters, growth performance and growth-related gene expression in Malaysian Mahseer *Tor tambroides*. *Aquaculture Nutrition*, 25(6), 1300-1317.
- Ashouri, G., Soofiani, N. M., Hoseinifar, S. H., Jalali, S. A. H., Morshedi, V., Valinassab, T., ... & Carnevali, O. (2020). Influence of dietary sodium alginate and *Pediococcus acidilactici* on liver antioxidant status, intestinal lysozyme gene expression, histomorphology, microbiota, and digestive enzymes activity, in Asian sea bass (*Lates calcarifer*) juveniles. *Aquaculture*, 518, 734638.
- Bakky, M. A. H., Tran, N. T., Zhang, Y., & Li, S. (2022). Utilization of marine macroalgae-derived sulphated polysaccharides as dynamic nutraceutical components in the feed of aquatic animals: A review. *Aquaculture Research*, 53(17), 5787-5808.
- Chen, G., Liu, B., Chen, J., Liu, H., Tan, B., Dong, X., ... & Yao, M. (2021). Supplementing Sulfate-Based Alginate Polysaccharide Improves Pacific White Shrimp (*Litopenaeus vannamei*) Fed Fishmeal Replacement with Cottonseed Protein Concentrate: Effects on Growth, Intestinal Health, and Disease Resistance. *Aquaculture Nutrition*, 2022. <https://doi.org/10.1155/2022/7132362>
- Cui, H., Wang, Z., Liu, J., Wang, Y., Wang, Z., Fu, J., ... & Zhang, M. (2020). Effects of a highly purified fucoïdan from *Undaria pinnatifida* on growth performance and intestine health status of gibel carp *Carassius auratus gibelio*. *Aquaculture Nutrition*, 26(1), 47-59.
- Doan, H., Hoseinifar, S. H., Tapingkae, W., Tongsiri, S., & Khamtavee, P. (2016). Combined administration of low molecular weight sodium alginate boosted immunomodulatory, disease resistance and growth enhancing effects of *Lactobacillus plantarum* in Nile tilapia (*Oreochromis niloticus*). *Fish & Shellfish Immunology*, 58, 678-685.

- Doan, H., Hoseinifar, S. H., Faggio, C., Chitmanat, C., Mai, N. T., Jaturasitha, S., & Ringø, E. (2018). Effects of corncob derived xylooligosaccharide on innate immune response, disease resistance, and growth performance in Nile tilapia (*Oreochromis niloticus*) fingerlings. *Aquaculture*, 495, 786-793.
- Encarnaçao, P. (2016). Functional feed additives in aquaculture feeds. In *Aqua-feed formulation* (pp. 217-237). Academic Press.
- FAO. 2022. The State of World Fisheries and Aquaculture 2022. Towards Blue Transformation. Rome, FAO. <https://doi.org/10.4060/cc0461en>
- Gora, A. H., Sahu, N. P., Sahoo, S., Rehman, S., Dar, S. A., Ahmad, I., & Agarwal, D. (2018). Effect of dietary *Sargassum wightii* and its fucoidan-rich extract on growth, immunity, disease resistance and antimicrobial peptide gene expression in *Labeo rohita*. *International Aquatic Research*, 10(2), 115-131.
- Jianbin, L., Ping, L., Qingguo, Z., & Manli, Q. (2017). Effect of laminarin on growth and immunity of pearl gentian grouper. *Animal Husbandry and Feed Science*, 9(4), 259-262.
- Jiang, H., Wang, M., Zheng, Y., Chen, F., Fu, L., Zhong, L., ... & Bian, W. (2021). Dietary laminarin administration to enhance the immune responses, promote growing and strengthen physique in *Ictalurus punctatus*. *Aquaculture Nutrition*, 27(4), 1181-1191.
- Jin, W., Lai, Y., & Zhu, F. (2021). Effect of dietary fucoidan on innate immune response of *Procambarus clarkii* and disease resistance against white spot syndrome virus. *Aquaculture*, 534, 736233.
- Kari, Z. A., Wee, W., Hamid, N. K. A., Dawood, M. A., Zakaria, N. N. A. B., & Wei, L. S. (2022). The roles of polysaccharides in tilapia farming: A review. *Aquaculture and Fisheries*. <https://doi.org/10.1016/j.aaf.2022.09.005>.
- Kraan, S. (2022). Seaweeds and Their Products for the Health of Livestock. *Sustainable Global Resources Of Seaweeds Volume 1*, 331-356.
- Mahgoub, H. A., El-Adl, M. A., Ghanem, H. M., & Martyniuk, C. J. (2020). The effect of fucoidan or potassium permanganate on growth performance, intestinal pathology, and antioxidant status in Nile tilapia (*Oreochromis niloticus*). *Fish physiology and biochemistry*, 46(6), 2109-2131.
- Mazlum, Y., Yazici, M., Naz, M. & Sayin, S. (2022). *Marine Biomaterials and Their Applications. Theory and Research in Agriculture, Forestry and Aquaculture Sciences*, , 103-124. Serüven Publishing.
- Nedaei, S., Noori, A., Valipour, A., Khanipour, A. A., & Hoseinifar, S. H. (2019). Effects of dietary galactooligosaccharide enriched commercial prebiotic on growth performance, innate immune response, stress resistance, intestinal microbiota and digestive enzyme activity in Narrow clawed crayfish (*Astacus leptodactylus* Eschscholtz, 1823). *Aquaculture*, 499, 80-89.

- Mir, I. N., Sahu, N. P., Pal, A. K., & Makesh, M. (2017). Synergistic effect of l-methionine and fucoidan rich extract in eliciting growth and non-specific immune response of *Labeo rohita* fingerlings against *Aeromonas hydrophila*. *Aquaculture*, 479, 396-403.
- Mir, I., Sushila, N., Bhat, I. A., Dar, S. A., Dar, J. Y., Muralidhar, A. P., & Syamala, K. (2018). Fucoidan: A Sulphated Polysaccharide and its Bioactive Potential in Aquaculture.
- Mohan, K., Ravichandran, S., Muralisankar, T., Uthayakumar, V., Chandirasekar, R., Seedeivi, P., ... & Rajan, D. K. (2019). Application of marine-derived polysaccharides as immunostimulants in aquaculture: A review of current knowledge and further perspectives. *Fish & shellfish immunology*, 86, 1177-1193.
- Morales-Lange, B., Bethke, J., Schmitt, P., & Mercado, L. (2015). Phenotypical parameters as a tool to evaluate the immunostimulatory effects of laminarin in *Oncorhynchus mykiss*. *Aquaculture research*, 46(11), 2707-2715.
- Moreira, A., Cruz, S., Marques, R., & Cartaxana, P. (2022). The underexplored potential of green macroalgae in aquaculture. *Reviews in Aquaculture*, 14(1), 5-26.
- Naiel, M. A., Alagawany, M., Patra, A. K., El-Kholy, A. I., Amer, M. S., & Abd El-Hack, M. E. (2021). Beneficial impacts and health benefits of macroalgae phenolic molecules on fish production. *Aquaculture*, 534, 736186.
- Neamat - Allah, A. N., El-Murr, A. E. I., & Abd El-Hakim, Y. (2019). Dietary supplementation with low molecular weight sodium alginate improves growth, haematology, immune reactions and resistance against *Aeromonas hydrophila* in *Clarias gariepinus*. *Aquaculture Research*, 50(5), 1547-1556.
- Patel, A. K., Vadrade, A. P., Singhania, R. R., Michaud, P., Pandey, A., Chen, S. J., ... & Dong, C. D. (2022). Algal polysaccharides: current status and future prospects. *Phytochemistry Reviews*, 1-30.
- Pereira, L. (2021). Macroalgae. *Encyclopedia*, 1(1), 177-188.
- Prabu, D. L., Sahu, N. P., Pal, A. K., Dasgupta, S., & Narendra, A. (2016). Immunomodulation and interferon gamma gene expression in sutchi cat fish, *Pangasianodon hypophthalmus*: effect of dietary fucoidan rich seaweed extract (FRSE) on pre and post challenge period. *Aquaculture research*, 47(1), 199-218.
- Quezada-Rodríguez, P., & Fajer-Ávila, E. J. (2017). The dietary effect of ulvan from *Ulva clathrata* on hematological-immunological parameters and growth of tilapia (*Oreochromis niloticus*). *Journal of Applied Phycology*, 29(1), 423-431.
- Raguraman, V., Ravindran, N., Selvaraju, K., & Kasivelu, G. (2020). Seaweed polysaccharides as potential therapeutic agents against white spot syndrome virus (WSSV): a mini review. *Aquaculture International*, 28(6), 2333-

2343.

- Saeed, M., Arain, M. A., Ali Fazlani, S., Marghazani, I. B., Umar, M., Soomro, J., ... & Alagawany, M. (2021). A comprehensive review on the health benefits and nutritional significance of fucoïdan polysaccharide derived from brown seaweeds in human, animals and aquatic organisms. *Aquaculture Nutrition*, 27(3), 633-654.
- Salehpour, R., Biuki, N. A., Mohammadi, M., Dashtiannasab, A., & Ebrahimnejad, P. (2021). The dietary effect of fucoïdan extracted from brown seaweed, *Cystoseira trinodis* (C. Agardh) on growth and disease resistance to WSSV in shrimp *Litopenaeus vannamei*. *Fish & Shellfish Immunology*, 119, 84-95.
- Santos, H. M., Tsai, C. Y., Yanuaria, C. A. S., Tayo, L. L., Vo, D. D., Mariatulqab-tiah, A. R., & Chuang, K. P. (2019). Effects of sodium alginate-fed Pacific white shrimps, *Litopenaeus vannamei*, on Toll-like receptors and *Vibrio alginolyticus* infection. *Aquaculture Research*, 50(4), 1384-1392.
- Sivagnanavelmurugan, M., Karthik Ramnath, G., Jude Thaddaeus, B., Palavesam, A., & Immanuel, G. (2014). Effect of Sargassum wightii fucoïdan on growth and disease resistance to *Vibrio parahaemolyticus* in *Penaeus monodon* post-larvae. *Aquaculture Nutrition*, 21(6), 960-969.
- Sony, N. M., Ishikawa, M., Hossain, M., Koshio, S., & Yokoyama, S. (2019). The effect of dietary fucoïdan on growth, immune functions, blood characteristics and oxidative stress resistance of juvenile red sea bream, *Pagrus major*. *Fish physiology and biochemistry*, 45(1), 439-454.
- Sony, N. M., Hossain, M., Ishikawa, M., Koshio, S., & Yokoyama, S. (2020). Efficacy of mozuku fucoïdan in alternative protein-based diet to improve growth, health performance, and stress resistance of juvenile red sea bream, *Pagrus major*. *Fish physiology and biochemistry*, 46(6), 2437-2455.
- Thepot, V., Campbell, A. H., Rimmer, M. A., & Paul, N. A. (2021). Meta-analysis of the use of seaweeds and their extracts as immunostimulants for fish: a systematic review. *Reviews in Aquaculture*, 13(2), 907-933.
- Tziveleka, L. A., Tammam, M. A., Tzakou, O., Roussis, V., & Ioannou, E. (2021). Metabolites with antioxidant activity from marine macroalgae. *Antioxidants*, 10(9), 1431.
- Vidhya Hindu, S., Chandrasekaran, N., Mukherjee, A., & Thomas, J. (2019). A review on the impact of seaweed polysaccharide on the growth of probiotic bacteria and its application in aquaculture. *Aquaculture International*, 27(1), 227-238.
- Vijayaram, S., Sun, Y. Z., Zuurro, A., Ghafarifarsani, H., Van Doan, H., & Hosenifar, S. H. (2022). Bioactive immunostimulants as health-promoting feed additives in aquaculture: A review. *Fish & Shellfish Immunology*, 130:294-308.
- Yang, M., Lu, Z., Li, F., Shi, F., Zhan, F., Zhang, Y., ... & Qin, Z. (2021). Alginate

- oligosaccharide improves fat metabolism and antioxidant capacity in the liver of grass carp (*Ctenopharyngodon idellus*). *Aquaculture*, 540, 736664.
- Yin, G., Li, W., Lin, Q., Lin, X., Lin, J., Zhu, Q., ... & Huang, Z. (2014). Dietary administration of laminarin improves the growth performance and immune responses in *Epinephelus coioides*. *Fish & shellfish immunology*, 41(2), 402-406.
- Yazici & Candan (2006). A Research on the Alternative Vaccination Methods Against Pasteurellosis in Seabass. *Su Ürünleri Dergisi*. 20, 1-16.
- Yazici, M., Mazlum, Y., Naz, M., Sayin, S., Ürkü, Ç. & Akayli, T. (2021). Effects of GroBiotic®-A supplementation on growth performance, body composition and liver and intestine histological changes in European Seabass (*Dicentrarchus Labrax*) juveniles. *Su Ürünleri Dergisi*, 38(1), 1-1.
- Yazici, M., Aktaş, M., Mazlum, Y., & Özbek, B.F. (2022). The effects of Dietary GroBiotic®-A on growth performance and survival rate of *Penaeus semi-sulcatus* (de Haan, 1844) juveniles. *Journal of Anatolian Environmental and Animal Sciences*, 7(3), 297-303.
- Yudiati, E., Isnansetyo, A., & Handayani, C. R. (2016). Innate immune-stimulating and immune genes up-regulating activities of three types of alginate from *Sargassum siliquosum* in Pacific white shrimp, *Litopenaeus vannamei*. *Fish & shellfish immunology*, 54, 46-53.





## **CHAPTER 8**

### **USING GIS TO CREATE A FOREST ROAD NETWORK**

*Metin TUNAY<sup>1</sup>, Salih KUVVETLİ<sup>2</sup>*

---

1 Prof. Dr. Bartın University, Bartın, Turkey, e-mail:mtunay@bartin.edu.tr Orcid No: 0000-0002-6065-0393

2 Forest Engineer Bartın University, Bartın, Turkey, e-mail:kuvvetli.salih@gmail.com Orcid No: 0000-0003-3816-8020

## Introduction

Opening forests to operation makes it possible to implement an intensive and purposeful rational forestry application. One of the most essentials tools required for this purpose is forest roads. These roads enable the movement of the raw material of wood, people, goods, and equipment, on the one hand, and the fulfillment of the transportation needs of the forest settlements as well as the needs of the populace for rest, on the other (Erdaş et al. 1995). In this way, these roads provide economic, social and even cultural benefits.

The most significant and most difficult stage of forest road planning studies is the determination of forest road routes. Making the wrong choice when planning a route will lead to issues with maintenance and the environment later on, as well as technical and financial issues during the construction phase.

The elimination of the harmful effects of water is necessary for the complete and rational operation of forest roads. Forest roads are affected by surface waters, groundwater, and waters from the basin at stream crossings. This effect is in the form of the destruction of the lower and upper structure material of the road. A good forest road is a road that is completely dry from the bottom to the top, where the surface and bottom waters are removed by maintaining certain limits, and the adverse effects of possible basin-originating waters, particularly floods in the stream crossings, are eliminated (Bayoğlu 1997).

The construction of forest roads consists of three stages: planning-projecting, construction and post-construction evaluation. The application of the road crossing alternative that causes the least damage to the forest by calculating the damage to the area caused by the construction of forest roads is important in terms of both ensuring the sustainability of the forest and increasing the productivity in production. Survey, preliminary project and final project stages of road planning studies in our country are generally carried out with the help of data obtained from geodesy studies.

It is necessary to obtain accurate and up-to-date information about the area and to evaluate the obtained information and use it in forest road planning while planning the road network in forest areas. The data that will serve for road planning and determination of the routes of the planned roads can be obtained with remote sensing data today instead of time-consuming and costly geodetic studies. This information obtained can be collected in the GIS database and queried and evaluated.

Geographic Information Systems (GIS) are information systems that collect, store, process, and display to the user the graphical and non-graphic data gathered through location-based observations in a comprehensive manner.

One of the most significant application areas of GIS is forestry, which deals with the operation, planning, and management of forests, one of the most important natural resources in the world (Rogers 2005).

Similar to how a well-designed and built highway network propels a nation's multidimensional growth, a well-designed and built forest road network is a crucial component of rational and sustainable forestry. Because in line with the aims and wishes of forestry, forest roads built on the basis of a road network planned in a way;

- That will open all sides of the forest to equal and sufficient operation,
- That will be compatible with the internal partition network of the forest,
- That will establish the most appropriate and shortest connection between the production site and the warehouse,

on the one hand, enable the economical transportation of forest products, the realization of more intensive silvicultural practices, the cultivation, planting and afforestation works, and the continuous and regular execution of forest protection and control works, in particular, the forest fires and insect disasters to be taken under surveillance and control, as well as the delivery of materials, equipment and personnel to workplaces, and on the other hand, meeting the road needs of the forest villagers and the recreational demands of the people (Acar 2005).

The General Directorate of Forestry initiated systematic forest road network planning studies in 1964 and completed these studies in 1974. In these studies, taking into account only the fertile forests, the total road length is planned as 144425 km. As of 1963, only 20691 km of the identified forest roads were included in these plans. The advancement of forestry technologies and techniques, the demands of rational forestry, and the outcomes of plan implementations in recent years have pushed for the modification of these plans, and under the current regulation, a total road length of 201810 km is planned (OGM 2011). The construction of forest roads to be built in accordance with the technique and by taking preventive measures against soil loss can minimize the damage to the environment.

The definition of a good forest road is "a road that is completely dry from the bottom to the top, where the surface and bottom waters are removed by maintaining certain limits, and the adverse effects of possible basin-originating waters, particularly floods in the stream crossings, are eliminated" (Bayoğlu1997).

It is done by clearing the water that collects on the road surface, the

slopes of the road, and the area around the road. Then, the road surface is given a single or double transverse slope, edge ditches and head ditches are established, and the water that collects in the channel is discharged to the opposite side of the road using hydraulic engineering structures like culverts and ducts.

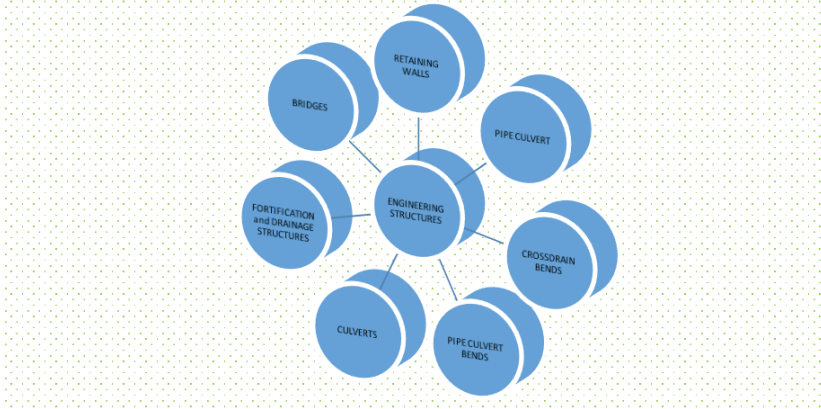

*Figure 1. Types of Forest Roads Engineering Structures*

A large part of our forests is scattered on mountainous terrain. It is possible to produce the raw material of wood in these areas and to transport them to the consumption centers continuously and regularly by building facilities such as retaining walls, floods and muscles to overcome floods and streams to prevent landslides along these roads (Çalışkan 2003).

In case of construction of 1 km of new road on a forest road route that is not chosen correctly and carefully;

- According to the road types, at least 4000 – 8000 m<sup>2</sup> of forest area is opened, 400 – 3500 trees are destroyed according to the age of the forest,
- As a result of the discharge of the excavated material down the slope, destruction is carried out by crushing, wounding, and inviting harmful insects,
- On the slopes, the supporting texture is broken and landslides are caused,
- The flow directions of shallow groundwater change and the ecosystem is negatively changed as a result of not being able to meet the water needs of natural stands,
- Breakage and rollovers are increased by creating wind corridors,
- Superficial flow and erosion are triggered,

- As a result of artificial and intense pressure on natural virgin areas with transportation, the right to life is restricted by making wildlife uneasy,
- The costs of road construction and maintenance are burdened with debt to the national economy.



Figure 2. GIS components

GIS is a decision-making system that stores, relates and displays information based on location. GIS is a kind of special digital database (Satır 2011). In the database, names such as X, Y, Z (latitude, longitude and height) coordinates, forest road, etc. can be used. GIS consists of the following parts.

- Maps, aerial photographs, satellite images and other resources for data entry.
- Data storage, retrieval and querying,
- Data transformation, analysis and modeling,
- Preparing a data report (maps, reports, and plans)

There are five important components of GIS study: hardware, software, data, people, and method (Esri 2002).

## Material and Method

In this study, where the GIS-based arrangement of the road network of Zonguldak Regional Directorate of Forestry Saltukova Forest Sub-district Directorate is discussed; According to the economic functions of the directory, the calculation and planning and arrangement of the construction costs of the road and engineering structures based on GIS were examined, taking into account the business classes and their justifications, function area boundaries, size, geographical locations, roads of other organizations, road-related planning studies, annual production amounts, working area boundaries, and area characteristics.

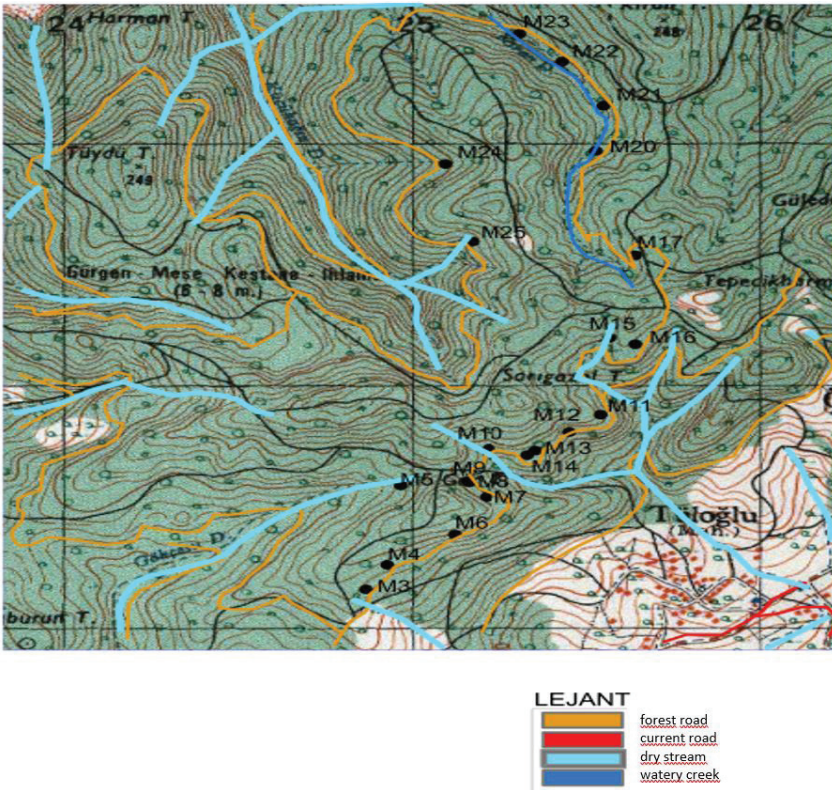

Figure 3. Location of Saltukova Forest District on the topographic map

Saltukova Forest Sub-district Directorate, which is the working area, has an area of 11517.7 hectares, 4339.5 hectares of which are forested areas, and 7178.2 hectares are open areas. Plan unit is located in 1/25000 scale topographic map no. E28d3, E28d4, F28a1, F28a2. All of the forests in the plan unit are owned and operated by the state.

It is located in the Western Black Sea Region of the Black Sea Region. The height above sea level varies between 380 meters at Darharman Hill on the eastern border, which is the highest point, and 0 meters on the northern border formed by the Black Sea, which is the lowest point, and it is located in the area between 32° 02' 50" – 32° 14' 50" east longitude to Greenwich and 41° 27' 10" – 41° 35' 50" north latitudes to the Equator. The sea height of Saltukova Forest Sub-district Directorate is around 190 m.

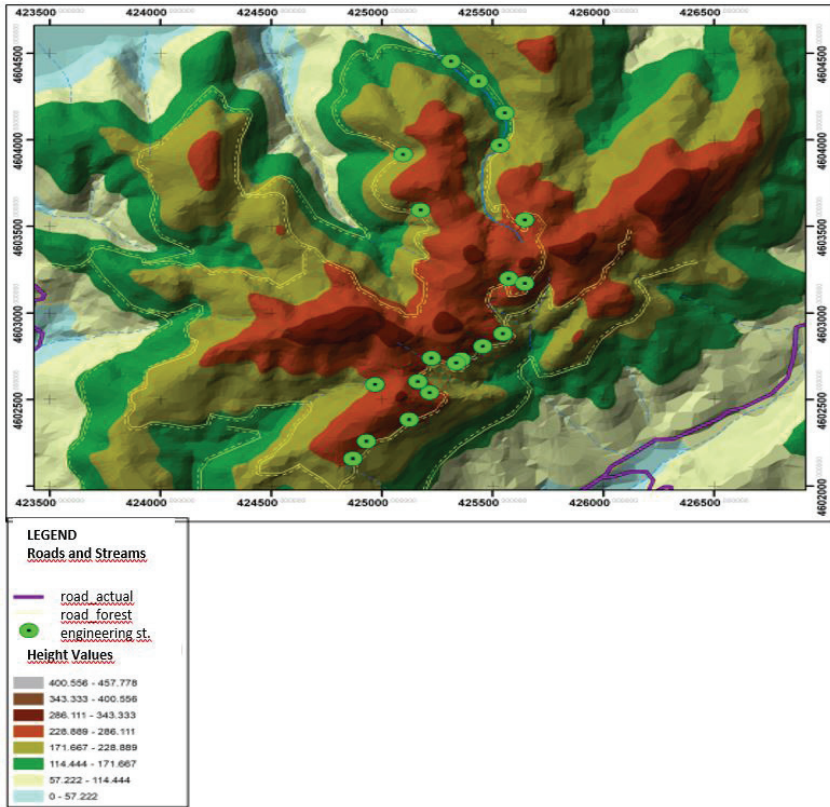

Figure 4. Roads, streams and height values of Saltukova Forest District

In the research, Esri ArcGIS 10.5 and ArcMap, ArcToolbox, ArcGlobe, ArcEditor, ArcGIS 3D Analyst and ArcScene applications included in this package were used as software in the analyzes required to benefit from Geographic Information Systems (GIS). In addition, NetCad 8, Google Earth, MS Office 2010 (Word, Excel) programs were also used. The ArcMap program is used for data viewing, data updating, data querying, and analysis, charting and reporting tools, and high-quality cartographic producing. NetCAD program was utilized to perform georeferencing, data production, analysis, creation of GIS projects, project management, and

transfer of projects to Google Earth. The Google Earth program was used to show the three-dimensional earthview of the study area.

For the presentation and documentation of this study, MS Office 2010 (Word, Excel) program was used. In addition, the Excel software included in the MS Office package was utilized to tabulate the coordinate data and to read these coordinate data on NetCAD and ArcGIS programs.

The DJI Phantom 4 Pro unmanned aerial vehicle, which provides 4K image quality, is used to examine existing roads on the territory and store data there and to investigate and designate projected valley and slope road routes on the terrain and to locate present and future facilities. In addition, GPS device, clinometer, altimeter, meter, compass, binoculars, and map were used for spatial measurements and coordinate retrieval.

In the planning of the forest roads of the Directorate Unit, the articles of Communiqué No. 292 on road density were meticulously complied with. Forestry services are currently being carried out with existing forest roads and neighborhood roads passing through the forest. After the needs-based determinations, appropriate road plans were made in places deemed insufficient. Based on these considerations, the roads constructed so far and the compulsory road planning to the places in need have increased the road density to 0.99%.

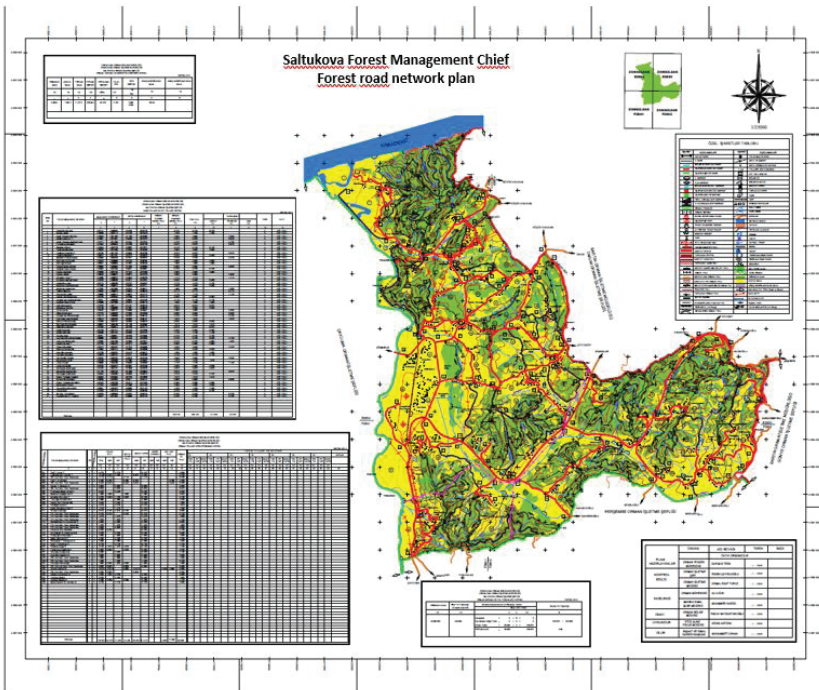

Figure 5. Forest road network of Saltukova Forest District

In the field controls of the existing forest roads of The Saltukova Forest Sub-district Directorate, 26+290 km of engineering structures that are robust and usable were identified. Roads without engineering structures are affected by rainfall and are destroyed because water discharge cannot be done properly. As these roads become more difficult to use, the cost of use also increases.

The road plan lines with 85+935 km length in the forest area 123+500 km of which was made by the General Directorate of Forestry, 166+745 km of which was made by the special provincial administration; were planned to be demonstrated in 23 different sketches.

### Findings

The study of Saltukova Forest Sub-district Directorate's Forest Road Network Plan, whose project is being carried out, has focused on the implementation of road planning that will address all transportation needs in the most cost-effective manner, minimize the loss of forest area, remain open to continuous and safe transportation, have the lowest construction and maintenance costs, and have the least environmental damage. In line with these thoughts, all of the existing roads of the directorate are planned and marked on the map sheets.

Table 1. Forest road density chart of Saltukova Forest District

FOREST AREA	nominal road density Forest Area/100	Existing and Planned Roads in the Forest Area					Actual Road Density
			Length	x	Width	=	
m <sup>2</sup>	m <sup>2</sup>		m		m		m <sup>2</sup>
43,395,000	433,950	Highways	=	0		10	0
		Country roads	=	0		6	0
		Forest roads	=	85,935		5	429,675
		<b>Total</b>	:	<b>85,935</b>			<b>429,675</b>

In the compartments where road planning is not required, it is thought that the tractor roads will be sufficient if necessary. When the nominal road density is calculated as 1% of the forest area, the area to be covered by the 5 m wide forest road to be included in this plan corresponds to a road area of 433950 m<sup>2</sup>. According to the relevant article of the Communiqué No. 292, the total length of the forest road corresponding to this calculated area is 86 +790 km.

As a result of the planning, since the forest road and village road length passing through the forest is 85+935 km. and the area covered is (forest road width 5 m. village road width 6 m.) 431425 m<sup>2</sup>, the road density is calculated as: 429675/433950 = 0.99% of the forest area.



Table 2. Sample road information form and itinerary

ORMAN İŞLETME MÜDÜRLÜĞÜ		ZONGULDAK		ROAD INFORMATION FORM AND ITINERARY																		
ORMAN İŞLETME SEFİLGİ		SALTUKOVA																				
KOD NO/SU		204																				
TİPİ		B																				
BAŞLANGIÇ VE SONU		Kayrak T-Gökçesu D.																				
KİLOMETRE BAŞLANGICI		0+000 - 3+650																				
KİLOMETRE ARASI				SARAT YAPILARI, KURPLAR VE SİZELER																		
Sıra No	Tufu	Kordinasyon			YOL MEYİL (%)	YOL GENİRLİĞİ (m)	YAMAĞ MEYİL (%)	HENDİEK DURUMU (Yer/Yok)	KILAS DURUMU		ÜST YAPI DURUMU (Hem / Stabilize)	YOL DURUM KODU	SARAT YAPILARI, KURPLAR VE SİZELER (Kırp. Mentez. Sız. Açık Yassa İstret/Duvar / Kırp. Lane)									
		Y	X	Z					Toprak %	Kaya %			CİNS	CİNS KODU	DarGeniş	Yarpça m.	Açıklık m.	En m.	Büy m.	Yükseklik m.	Çap cm.	
1	2	3	4	5	6	7	8	9	10	11	12	13	14	15	16	17	18	19	20	21	22	
1	0+000	423.862	4.802.874	133																		
2	3+650	424.164	4.802.191	170		45		80	40		2											

The cost of the various engineering structures totals 78475.00 TL and they span a distance of 3+650 km in the Kayrak Tepe-Gökçesu Stream Line with the 204 Code. Major repair operations such as trenching and road expansion were not carried out on the road line and the total cost of this road line was 183018.00 TL.

### Conclusions

In the field controls of the existing forest roads of the Saltukova Forest Sub-district Directorate, for which the project was made, 26+290 km of engineering structures were identified that are durable and usable. Based on this situation, a 97+210 km engineering structure program was given, including all existing and newly planned forest roads. Zonguldak Regional Directorate of Forestry, Saltukova Forest Sub-district Directorate within the scope of the data of the Forestry Operations Chief's Management Plan, the borders of the Chiefdom were determined by making use of 1/25000 scaled maps, the plan unit was surveyed in the field by making use of the existing roads, and the necessary determinations were made with GPS and other current measuring instruments. In addition, existing roads, forest conditions, superstructure material quarry locations, if any, and other necessary information were determined, and were written on 1/25000 scale maps. The slope roads and road connections, which are planned to be newly built, were determined in terms of their routes, firstly by watching them from the closest and dominant points with the eye and binoculars, and the valley roads were determined by visiting their routes and checking them with a clinometer in the field. Thus, the most suitable and economical routes for forestry services were determined.

In this study, it was determined that time and effort were reduced with GIS software and the desired queries could be easily reached. The places and locations of the engineering structures needed on the forest roads were determined and shown on the map created. We can see GIS technology in different applications in the forestry sector as well as in many professional

fields. It is of great importance that the forest roads, which are indispensable for the sustainability of forestry works, can serve for a long time and that the maintenance costs do not increase. With the help of GIS, it has been demonstrated that the forest road network and necessary engineering structures of a forest enterprise can be planned in a short time and easily.

## References

- Erdaş O., Acar H. H., Tunay M., & Karaman, A., 1995. Türkiye'de Orman İşçiliği ve Üretim, Orman Yolları, Orman Ürünleri Transportu, Ormancılıkta Mekanizasyon ve Mülkiyet-Kadastro ile İlgili Sorunlar ve Çözüm Önerileri, Türkiye Ormancılık Raporu, KTÜ Orman Fak.Yay. No:48, 44-79, Trabzon.
- Bayoğlu S., 1997. Orman Transport Tesisleri ve Taşıtları (Orman Yolları) .İ.Ü. Orman Fakültesi yayın No: 434. İstanbul.
- Rogers L. W., 2005. Automating Contour-Based Route Projection for Preliminary Forest Road Designs Using GIS, Master of Science, University of Washington.
- Acar H., 2005. Orman Yolları, KTÜ Orman Fakültesi, Trabzon.
- OGM 2011. 2010 Yılı Yatırım İzleme ve Değerlendirme Raporu, T.C. Çevre ve Orman Bakanlığı Orman Genel Müdürlüğü Strateji Geliştirme Dairesi Başkanlığı, Ankara.
- Çalışkan E., 2003. Dağlık Arazide Orman Yolu Sanat Yapılarının Yerlerinin ve Boyutlarının Belirlenmesi Üzerine Bir Araştırma. Karadeniz Teknik üniversitesi Fen Bilimleri Enstitüsü Doktora Tezi.
- Satır O., 2011. Dağlık Arazide Coğrafi Bilgi Sisteminden Yararlanarak Çevreye Duyarlı Orman Yolu Güzergahının Belirlenmesi. Artvin Çoruh Üniversitesi Fen Bilimleri Enstitüsü Doktora Tezi.
- ESRI Inc. 2002. GIS Mapping Software, [www.esri.com](http://www.esri.com).





## **CHAPTER 9**

### **ASSESSMENT OF TRACE ELEMENTS POLLUTION LEVELS IN SEDIMENTS AND OF ENVIRONMENTAL, ECOLOGICAL AND HUMAN HEALTH RISK BY SOME QUALITY INDICES- A REVIEW**

*Özgür CANPOLAT<sup>1</sup>,  
Memet VAROL<sup>2</sup>,  
Metin ÇAĞLAR<sup>3</sup>*

---

1 Prof. Dr. Faculty of Fisheries, Fırat University, Elazığ, Turkey (ORCID: 0000-0001-7498-600X)

2 Doğanşehir Vahap Küçük Vocational School, Department of Aquaculture,, Malatya Turgut Ozal University, Malatya, Turkey (ORCID: 0000-0001-6475-0570)

3 Faculty of Fisheries, Fırat University, Elazığ, Turkey (ORCID: 0000-0002-0442-2281)

Aquatic ecosystems are of vital importance in the life of all living things (such as water and food supply, flood and climate regulation, social and economic development), (Messenger et al., 2016; Li et al., 2022). Therefore, aquatic ecosystems constitute the essential component of both ecological and biogeochemical processes of the earth system. Unfortunately, in parallel with rapid industrialization and urbanization in recent years, large amounts of inorganic and organic pollutants have accumulated in aquatic ecosystems through multiple pathways (Li et al., 2019; Li et al., 2022).

Maintaining water quality for the sustainable use of water resources plays an important role in urban development and the environment, especially in developed and developing countries. There are thousands of chemical pollutants in surface waters. Trace elements (TEs) are among the most dangerous chemical pollutants for the environment and humans due to their high toxicity and carcinogenicity (Proshad et al., 2019; Ustaoglu and Aydın, 2020).

Sediments are an important component of aquatic ecosystems, as they provide habitat for many benthic organisms, as well as support biodiversity and play an important role in maintaining the aquatic environment quality (Islam et al., 2020; Zhuang et al., 2021). Pathogens, nutrients, TEs and organic chemicals eventually accumulate in the sediment as both inorganic and organic substances tend to be absorbed onto the sediment. Therefore, because sediments have the ability to accumulate pollutants, they act as a source of pollution in their ecosystems (Burton, 2002).

Sediment contamination with trace elements (TEs) could be either from natural geogenic sources or sourced from anthropogenic activities (Giouri et al., 2010; Astatkie et al., 2021). TEs are considered as important pollution in aquatic ecosystems due to their high toxicity, environmental persistence, biological accumulations and negative effects on human health through food chain (Elkady et al., 2015; Li et al., 2018; Hu et al., 2019; Birch, 2017; Stefanovic et al., 2016; Yu et al., 2021). TEs are discharged into aquatic system through natural weathering (rock weathering, wind-borne soil particles) and intensive anthropogenic activities (agricultural cultivation, industrial effluents, mining and smelting, transportation, transportation, sewage runoff and energy production related activities) and then deposit in the sediments (Hahladakis and Smaragdaki, 2013; Jaisankar et al., 2014; Islam et al., 2015; Kang et al., 2017; Hu et al., 2019; Duodu et al., 2016; Vasiliu et al., 2020).

Sediment risk assessment is a specific application of ecological risk assessment. It may include aspects of a human health risk assessment, as well, to examine the direct and indirect consequences of sediment conditions on human health. Figure 1 provides an overview of a sediment risk

assessment process ([https://www.enviro.wiki/index.php?title=Contaminated\\_Sediment\\_Risk\\_Assessment#cite\\_note-Chapman1996-26](https://www.enviro.wiki/index.php?title=Contaminated_Sediment_Risk_Assessment#cite_note-Chapman1996-26)).

In this study, information was given about assessment of TEs pollution levels in sediments and of environmental, ecological and human health risk by some quality indices in aquatic ecosystems.

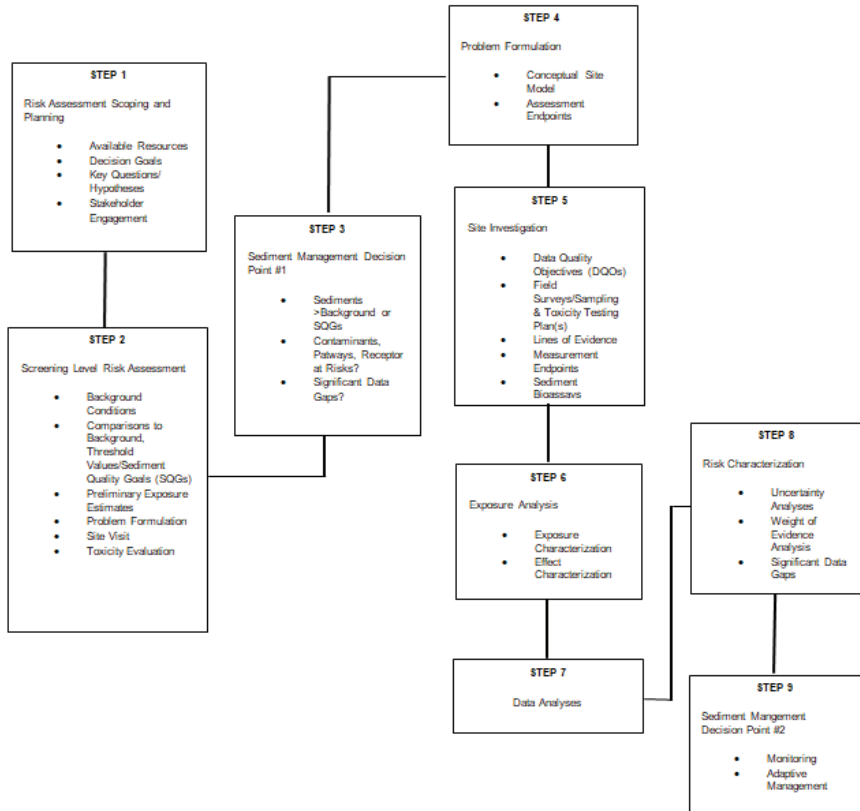

**Figure 1.** Schematic of the sediment risk assessment process ([https://www.enviro.wiki/index.php?title=Contaminated\\_Sediment\\_Risk\\_Assessment#cite\\_note-Chapman1996-26](https://www.enviro.wiki/index.php?title=Contaminated_Sediment_Risk_Assessment#cite_note-Chapman1996-26))

## 1. ENVIRONMENTAL RISK ASSESSMENTS (ERA)

Different indices have been developed to determine pollution status of TEs and anthropogenic effect levels in the sediment such as enrichment factor (EF), geo-accumulation index (Igeo), contamination factor (CF), pollution load index (PLI) and metal enrichment index (MEI).

Environmental risk assessment (ERA) is a flexible process for organizing and analyzing data, assumptions, and uncertainties to evaluate the

probability of adverse ecological effects that may have occurred or occur as a result of exposure to one or more stressors related to sources of ecological risk (Shu and Xu, 2012). The concept of ERA was first proposed by the U.S. Environmental Protection Agency (USEPA) in its Framework for Ecological Risk Assessment (USEPA, 1992). Then, the Guidelines for Ecological Risk Assessment (USEPA, 1998) presented an ERA framework consisting of three primary phases: problem formulation, analysis, and risk characterization. The objective of ERA is to provide reliable quantitative evidence for ecological environment risk management and decision making (Shu and Xu, 2012).

Environmental risk assessment (ERA) is an important method to determine TEs contamination levels in sediment (Varol et al., 2022). ERA, including sediment assessments, are typical tools for supporting decision making in the regulatory context, and cover all kinds of spatial situations, from local to worldwide assessments, under very different regulatory contexts (Tarazona et al., 2014).

### 1.1. Enrichment Factor (EF)

An enrichment factor (EF) is a widely used tool for assessing TEs contamination in sediments are naturally (from rocks) or anthropogenic sources and also calculate the rate of pollutants in sediments (MacDonald et al., 2000). Thus, it is possible to understand the status and degree of environmental pollution with this index. In other words EF determines the anthropogenic contribution to the TEs concentration. It is obtained by dividing the ratio between the current element concentration and Al by the ratio of Al in the element concentration in uncontaminated sediments pertaining to the pre-contamination period (Zhang et al., 2007).

EF is expressed as follow:

$$EF = \left[ \frac{C_i}{C_{Al}} \right]_{sample} / \left[ \frac{C_i}{C_{Al}} \right]_{background}$$

where  $(C_i/C_{Al})_{Sediment}$  is the ratio of the concentration of a particular metal  $i$  ( $C_i$ ) to the Al concentration ( $C_{Al}$ ) in the sediment sample; and  $(C_i/C_{Al})_{Background}$  is the ratio of the background concentration of a particular metal  $i$  ( $C_i$ ) to the reference background concentration of Al ( $C_{Al}$ ). Either Al or Fe has been used as a conservative element for EF calculations in many studies to distinguish the source of TEs (Wu et al., 2010; Zhuang et al., 2021; Canpolat et al., 2022). In this study, Al was selected as a reference metal.

EF<2 minimal enrichment or no enrichment;

- EF=2-5 moderate enrichment;
- EF=5-20 significant enrichment;
- EF=20-40 high enrichment;
- EF>40 extremely high enrichment.

### 1.2. Geo-Accumulation Index (Igeo)

The geo-accumulation index (Igeo) is another evaluating indicator often used to assess the pollution in sediments. It takes the influence of human activities and natural geological processes on the background value into account. It can be used to quantitatively evaluate the degree of TEs pollution in sediments or other substances (Hui et al., 2015; Zheng et al., 2015). The formula for Igeo is defined as (Müller and Putz, 1969):

$$I_{geo} = \log_2 \left[ \frac{C_k^i}{1.5 \times C_n^i} \right]$$

where  $C_k^i$  is the concentration of heavy metal in the sediment and  $C_n^i$  is the geochemical background concentration of the trace element (i), and factor 1.5 refers to the possible variation in background values caused by lithogenic and weathering effects. The Igeo for trace element is classified in seven classes (Müller and Putz, 1969) as the following presentation:

- $I_{geo} \leq 0$  uncontaminated;
- $0 < I_{geo} \leq 1$  slightly contaminated;
- $1 < I_{geo} \leq 2$  moderately contaminated;
- $2 < I_{geo} \leq 3$  moderately to heavily contaminated;
- $3 < I_{geo} \leq 4$  heavily contaminated;
- $4 < I_{geo} \leq 5$  severely contaminated;
- $I_{geo} > 5$  extremely contaminated.

### 1.3. Contamination Factor (CF)

Another method that was used to determine contamination levels was the Contamination Factor (CF), which is the ratio of trace element concentration to background trace element concentration. CF is calculated using the following formula (Hakanson 1980):

$$C_f^i = \frac{C_a^i}{C_b^i}$$

$C_f^i$ : Contamination factor

$C_d^i$ : Concentration value measured in lake sediment

$C_b^i$ : Background metal concentration rate

The contamination value is classified into four groups (Hakanson 1980):

$CF < 1$  low contamination;

$1 \leq CF < 3$  moderate contamination;

$3 \leq CF < 6$  high contamination;

$CF > 6$  very high contamination.

#### 1.4. Pollution Load Index (PLI)

This index shows the magnitude of TEs pollution in sediment and also Igeo also use for this reason. It is formulated as follow (Bonnail et al., 2016):

$$PLI = (C_{f1} \times C_{f2} \times C_{f3} \dots \times C_{fn})^{1/n}$$

n = number of metals and

CF = contamination factor

PLI = 1 baseline

PLI < 1 no pollution

PLI > 1 pollution

#### 1.5. Metal Enrichment Index (MEI)

This index is applied in an industrial area when investigating anthropogenic relationship with TEs accumulation (Mazurek et al., 2017; Riba et al., 2002). This index has been reported to be more suitable for use in TEs deposits in surface sediment and is also called surface sediment index and it is formulated as follow (Mazurek et al., 2017):

$$MEI = (C_A - C_B) / C_A$$

where  $C_A$  and  $C_B$  stands for total concentration of individual TEs and stands for background level, respectively

1= no enrichment;

- 2=low enrichment;
- 3=moderate enrichment;
- 4=strong enrichment;
- 5=extremely enrichment

## 2. ECOLOGICAL RISK ASSESSMENT (ERA)

### 2.1. Potential Ecological Risk Index (PERI)

The potential ecological risk factor (PERI) is established on the sensitivity factor, sink-effect, and abundance principle. PERI has been extensively employed as an investigative tool for contamination monitoring since its improvement in the 1980s (Ma and Han, 2019).

PERI was introduced by Hakanson (1980) based on sedimentological theory. Because of its comprehensive consideration of both the pollution degrees and the toxicities of TEs, PERI has been widely used to evaluate the comprehensive potential ecological risk of TEs in sediments (Rao et al., 2021; Waara and Johansson, 2022).

Hence, PERI can be calculated by the following formula (Hakanson 1980):

$$E_r^i = T_r^i \times (C_n / C_{ref})$$

where  $E_r^i$  is the potential ecological risk index of trace element,  $T_r^i$  represents the toxic-response factor,  $C_n$  stands for the metal concentration in the research subjects, and  $C_{ref}$  indicates the reference value. The  $T_r^i$  coefficients of for each element were obtained from previously published studies (Table 1).

**Table 1.** Toxic response factors used for calculating the Potential Risk Index (Hakanson, 1980)

Element	$T_r^i$	Reference
As	10	Hakanson, 1980
Ba	2	Yang et al., 2015
Cd	30	Hakanson, 1980
Co	5	Zhang et al., 2017
Cr	2	Hakanson, 1980
Cu	5	Hakanson, 1980
Ni	5	Zhang et al., 2017
Pb	5	Hakanson, 1980
Sb	7	Wang et al., 2018
V	2	Zhu et al., 2013
Zn	1	Hakanson, 1980

The assessed  $E_r^i$  value may be grouped as follows

$E_r^i < 40$  low;

$40 \leq E_r^i < 80$  moderate;

$80 \leq E_r^i < 160$  noticeable;

$160 \leq E_r^i < 320$  high;

$320 \geq E_r^i$  major.

## 2.2. Ecological Risk Index (RI)

The RI method was developed by Hakanson (1980) for assessing the potential ecological risks in sediment in freshwater ecosystems in Sweden. This was determined from the quantity of seven elements (As, Cd, Cr, Cu, Hg, Pb and Zn) and one persistent organic pollutant (PCB), and continues to be used for ecological risk assessments of TEs in sediments (Manoj and Padhy 2014; Duodu et al. 2016; Wang et al. 2018; Wei et al. 2019; Li et al. 2020). Although sediment quality guidelines (SQGs) and Igeo are reliable to evaluate the toxicities of TEs in sediments (Zhang et al., 2017; Rao et al., 2021), they do not comprehensively consider the synergistic effects of multiple TEs pollution (Duodu et al., 2016; Waara and Johansson, 2022). The RI is used for overall assessment of ecological risks of several TEs in the sediment.

$$\sum_{i=1}^n E_r^i = \sum_{i=1}^n T_r^i \times C_f^i \quad (\text{Hakanson, 1980})$$

where  $T_r^i$  is the toxic response factor of substance  $i$ ,  $C_f^i$  is the contamination factor of substance  $i$ .

The assessed RI value may be grouped as follows:

$RI \leq 150$  low risk;

$150 < RI \leq 300$  moderate risk;

$300 < RI \leq 600$  relatively high risk;

$RI > 600$  extremely high risk;

## 2.3. Sediment Quality Guidelines (SQGs)

SQGs were often employed to assess the intensity of biological effects of TEs in sediments (Rao et al., 2021). There have been numerous sediment quality guidelines (SQGs) developed during the past 20 years to assist regulators in dealing with contaminated sediments (Burton, 2002). Before the 1980s, the contamination level of sediments was determined by comparing the concentration of a chemical in sampled sediments to “back-

ground” or reference values. It was recognized that this approach does not account for the types of biological resources in an aquatic environment or the concentration at which an adverse response would be observed in these organisms. To improve on this method, sediment quality guidelines (SQGs) have since been developed for use in assessing sediment quality, meaning contaminant concentrations that cause adverse effects (Ingersoll and Wenning, 2002; Burton, 2002).

In SQGs, adverse biological effects of TEs are unlikely to happen when the TE concentrations are lower than the threshold effect concentrations (TEC), while adverse biological effects are expected to happen when the heavy metal concentrations are higher than the probable effect concentrations (PEC) (Table 2), (MacDonald et al., 2000; Wenning et al., 2005; Rao et al., 2021).

**Table 2.** Sediment quality guidelines (SQGs) with TE concentrations (mg/kg)

	As	Cd	Cr	Cu	Ni	Pb	Zn	Hg
TEC	9.79	0.99	43.4	31.6	22.7	35.8	121	0.18
PEC	33	4.98	111	149	48.6	128	459	1.06

### 3. HUMAN HEALTH RISK ASSESSMENT (HHRA)

Human health risk assessment (HHRA) of sediments is commonly used to assess both carcinogenic and non-carcinogenic risks to people through three exposure pathways: ingestion, inhalation, and dermal contact. In this study, information was given about the routes of exposure through exposure pathways ingestion and dermal contact. The HHRA technique was based on the US Environmental Protection Agency’s guidelines and Exposure Factors Handbook (USEPA, 1986, 1989, 1997, 2001).

For receptors (adults and children), carcinogenic and non-carcinogenic health risks from exposure to TEs in sediments via ingestion and dermal absorption routes were estimated (USEPA, 2020a). Carcinogenic risk (CR) was estimated only for arsenic which has a carcinogenic slope factor (Li et al., 2014; Canpolat et al., 2021). Hazard quotients (HQs) were calculated to evaluate non-carcinogenic risks of all TEs in sediment. To estimate health risk indices, the following equations were used (USEPA, 2020b). Tables 3 and 4 provide all descriptions, definitions, units and values for these equations.

**Table 3.** *Parameters and their symbols, units and values for health risk assessment*

Parameters	Symbols	Units	Values	References
Element concentration	$C_s$	mg/kg		Site-specific
Body weight-adult	$BW_a$	kg	70	Site-specific
Body weight-child	$BW_c$	kg	15	USEPA (1991b)
Exposure duration-child	$ED_c$	years	6	USEPA (1991b)
Exposure duration-adult	$ED_a$	years	20	USEPA (2020d)
Exposure frequency	EF	days/year	135	Site-specific
Exposure time	ET	hours/event	2	Site-specific
Skin surface area-adult	$SA_a$	cm <sup>2</sup>	6032	USEPA (2011)
Skin surface area-child	$SA_c$	cm <sup>2</sup>	2373	USEPA (2011)
Sediment intake ratio-adult	$IRS_a$	mg/day	100	USEPA (1991b)
Sediment intake ratio-child	$IRS_c$	mg/day	200	USEPA (1991b)
Averaging time-child	$AT_c$	days	365 x $ED_c$ (non- carcinogenic)	USEPA (1989)
Averaging time-adult	$AT_a$	days	365 x $ED_a$ (non- carcinogenic)	USEPA (1989)
Adherence factor-adult	$AF_a$	mg/cm <sup>2</sup>	0.07	USEPA (2002)
Adherence factor-child	$AF_c$	mg/cm <sup>2</sup>	0.2	USEPA (2002)
Sediment ingestion ratio	IFS	mg/kg	Age-adjusted	USEPA (2020d)
Sediment dermal contact factor	DFS	mg/kg	Age-adjusted	USEPA (2020d)
Life time	LT	years	70	USEPA (1989)
Averaging time	AT	days	365 × LT = 25550 (carcinogenic)	USEPA (1989)

**Table 4.** *Relative bioavailability factor, dermal absorption fraction, reference dose, slope factor and gastrointestinal absorption coefficient for each element*

Element	Relative bioavailability factor (RBA; unitless)	Dermal absorption fraction ( $ABS_d$ ; unitless)	Oral reference dose (RfD <sub>o</sub> ; mg/kg-day)	Oral slope factor (CSF <sub>o</sub> ; mg/kg-day)	Gastrointestinal absorption (GIABS; unitless)
As	0.6	0.03	0.0003	1.5	1
Cd	1	0.001	0.001		0.025
Co	1	0.001	0.0003		1
Cr	1	0.001	1.5		0.013
Cu	1	0.001	0.04		1
Fe	1	0.001	0.7		1
Mn	1	0.001	0.024		0.04
Ni	1	0.001	0.02		0.04
Pb	1	0.001	0.0014		1
Zn	1	0.001	0.3		1
Al	1	0.001	1		1
Sb	1	0.001	0.0004		0.15
Ba	1	0.001	0.2		0.07
Be	1	0.001	0.002		0.007
La	1	0.001	0.00005		1
Hg	1	0.001	0.00016		1
Mo	1	0.001	0.005		1
Sr	1	0.001	0.6		1
Tl	1	0.001	0.00001		1
W	1	0.001	0.0008		1
U	1	0.001	0.0002		1
V	1	0.001	0.00504		0.026
Zr	1	0.001	0.00008		1
References	USEPA (2020c)	USEPA (2020d)	USEPA (2020d)	USEPA (2020d)	USEPA (2020d)
			Li et al. (2014)		

### 3.1. Sediment

#### 3.2.1. Non-cancer health risks for adults and children

$$HQ_{ingestion - adult} = \frac{C_S \times IRS_a \times RBA \times EF \times ED_a}{BW_a \times AT_a \times RfD_a \times 10^6}$$

$$HQ_{ingestion - child} = \frac{C_S \times IRS_c \times RBA \times EF \times ED_c}{BW_c \times AT_c \times RfD_c \times 10^6}$$

$$HQ_{dermal - adult} = \frac{C_S \times SA_a \times AF_a \times ABS_d \times EF \times ED_a}{BW_a \times AT_a \times RfD_a \times GIABS \times 10^6}$$

$$HQ_{dermal - child} = \frac{C_S \times SA_c \times AF_c \times ABS_d \times EF \times ED_c}{BW_c \times AT_c \times RfD_c \times GIABS \times 10^6}$$

#### 3.2.2. Cancer health risks

$$CR_{ingestion} = \frac{C_S \times IFS \times RBA \times CSF_o}{AT \times 10^6}$$

$$IFS = \frac{EF \times ED_a \times IRS_a}{BW_a} + \frac{EF \times ED_c \times IRS_c}{BW_c}$$

$$CR_{dermal} = \frac{C_S \times DFS \times ABS_d \times CSF_o}{AT \times GIABS \times 10^6}$$

$$DFS = \frac{EF \times ED_a \times SA_a \times AF_a}{BW_a} + \frac{EF \times ED_c \times SA_c \times AF_c}{BW_c}$$

#### 3.3.3. Total non-cancerous risk

A Hazard Indices (HI) value less than 1.0 indicates that there was no

considerable risk of non-carcinogenic consequences. A HI of greater than 1.0 indicates the possibility of non-carcinogenic effects. Non-carcinogenic effects are likely to have a favorable relationship with the increase in the HI value (Hussain et al., 2015).

The HI was calculated according to equation:

$$\text{Hazard Indices (HI)} = \text{HQ(As)} + \text{HQ(Cd)} + \dots + \text{HQ(Pb)} + \text{HQ(Zn)}$$

$$\text{Total HI} = \text{HI}_{\text{ingestion}} + \text{HI}_{\text{dermal}}$$

#### **3.3.4. Total cancer risk**

$$\text{Total CR} = \text{CR}_{\text{ingestion}} + \text{CR}_{\text{dermal}}$$

### **Conclusion**

In addition to the sustainable use of water resources, the protection of both the environment and human health is among the priority agenda items of all countries. Therefore, environmental, ecological and human health effects of trace elements in the sediment have gained great importance in recent years and have started to be among the current research topics. This review will contribute to the research to be done in this field.

## References

- Astatkie, H., Ambelu, A., Mengistie, E. (2021). Contamination of stream sediment with heavy metals in the Awetu Watershed of Southwestern Ethiopia. *Frontiers Earth Science*, 9,1-13.
- Birch, G.F. (2017). Assessment of human-induced change and biological risk posed by contaminants in estuarine/harbour sediments: sydney Harbour/estuary (Australia). *Mar. Pollut. Bull.* 116 (1,2), 234-248
- Bonnail, E., Sarmiento, A.M., Del Valls, T.A., Nieto, J.M., Riba, I. (2016). Assessment of metal contamination, bioavailability, toxicity and bioaccumulation in extreme metallic environments (Iberian Pyrite Belt) using *Corbicula fluminea*, *Science of the Total Environment*, 544,1031-1044.
- Burton, G., Allen, Jr. (2002). Sediment quality in use around the world. *Limnology*, 3, 65-75.
- Canpolat, O.,Varol, M., Oztekin Okan, O., Eriş, K.K. (2021). Sediment contamination by trace elements and the associated ecological and health risk assessment: A case study from a large reservoir (Turkey). *Environmental Research*, 204,1-10
- Duodu, G.O., Goonetilleke, A., Ayoko, G.A. (2016). Comparison of pollution indices for the assessment of heavy metal in Brisbane River sediment. *Environ. Pollut.* 219,1077-1091.
- Elkady, A.A., Sweet, S.T., Wade, T.L., Klein, A.G. (2015). Distribution and assessment of heavy metals in the aquatic environment of Lake Manzala, Egypt. *Ecol. Indicat.* 58,445–457.
- Giouri, A., Christophoridis, C., Melfos, V., Vavelidis, M. (2010). Assessment of heavy metals concentrations in sediments of Bogdanas River at the Assiros-Lagadas Area, 100,63-70.
- Hahladakis, J., Smaragdaki, E., Vasilaki, G., Gidarakos, E. (2013). Use of sediment quality guidelines and pollution indicators for the assessment of heavy metal and PAH contamination in Greek Surficial Sea and lake sediments. *Environ. Monit. Assess.* 185,2843-2853.
- Hakanson, L. (1980). An ecological risk index for aquatic pollution control. A sedimentological approach, *Water Research*, 14,8,975-1001.
- [https://www.enviro.wiki/index.php?title=Contaminated\\_Sediment\\_Risk\\_Assessment#cite\\_note-Chapman1996-26](https://www.enviro.wiki/index.php?title=Contaminated_Sediment_Risk_Assessment#cite_note-Chapman1996-26)
- Hu, J., Long, Y., Zhou, W., Zhu, C., Yang, Q., Zhou, S., Wu, P. (2020). Influence of different land use types on hydrochemistry and heavy metals in surface water in the lakeshore zone of the Caohai wetland, China. *Environ. Pollut.* 267,115454.
- Hui, Y., Yuan, S.Y., Li, M.Y., Xiao, J. (2015). Evaluation of heavy metal contamination in agricultural topsoils in suburban Xuchang City, China. *Environ. Earth Sci.*, 74,2475-2480.

- Hussain, R., Khattak, S.A., Shah, M.T., Ali, L. (2015). Multistatistical approaches for environmental geochemical assessment of pol-lutants in soils of Gadoon Amazai Industrial Estate, Pakistan. *J. Soil. Sediment*,15,1119-1129.
- Ingersoll, C.G., Wenning, R.J. (2002). Use of sediment quality guidelines and related tools for the assessment of contaminated sediments: Executive summary of a SETAC Pellston Workshop. Society of Environmental Toxicology and Chemistry.
- Islam, M.S., Ahmed, M.K., Raknuzzaman, M., Habibullah-Al-Mamun, M., Islam, M.K. (2015). Heavy Metal Pollution in Surface Water and Sediment: A Preliminary Assessment of an Urban River in a Developing Country. *Ecol. Indicators* 48,282-291.
- Islam, M.A., Das, B., Quraishi, S.B., Khan, R., Naher, K., Hossain, S.M., Karmaker, S., Latif, S.A., Hossen, M.B. (2020). Heavy metal contamination and ecological risk assessment in water and sediments of the Halda river, Bangladesh: A natural fish breeding ground. *Marine Pollution Bulletin*, 160,111649.
- Jaishankar, M., Tseten, T., Anbalagan, N., Mathew, B. B., Beeregowda, K.N. (2014). Toxicity, Mechanism and Health Effects of Some Heavy Metals. *Interdiscip. Toxicol.* 7(2),60-72.
- Kang, X.M., Song, J.M., Yuan, H.M., Duan, L.Q., Li, X.G., Li, N., Liang, X.M., Qu, B.X. (2017). Speciation of heavy metals in different grain sizes of Jiaozhou Bay sediments: bioavailability, ecological risk assessment and source analysis on a centennial timescale. *Ecotoxicol. Environ. Saf.* 143, 296-306.
- Li, M., Ma, Z., van der Kuijp, T.J., Yuan, Z., Huang, L. (2014). A review of soil heavy metal pollution from mines in China: pollution and health risk assessment. *Sci. Total Environ.* 468–469, 843–853.
- Li, F., Zhang, J.D., Liu, C.Y., Xiao, M.S., Wu, Z.X. (2018). Distribution, bioavailability and probabilistic integrated ecological risk assessment of heavy metals in sediments from Honghu Lake, China. *Process Saf. Environ. Protect.* 116,169-179.
- Li, Y., Zhou, Q., Ren, B., Luo, J., Yuan, J., Ding, X., Bian, H., Yao, X. (2019). Trends and health risks of dissolved heavy metal pollution in global river and lake water from 1970 to 2017. In: *Reviews of Environmental Contamination and Toxicology*, 251,1-24.
- Li, M., Zhang, Q., Sun, X., Karki, K., Zeng, C., Pandey, A., Rawat, B., Zhang, F. (2020). Heavy metals in surface sediments in the trans-Himalayan Koshi River catchment: Distribution, source identification and pollution assessment. *Chemosphere*, 244,125410.
- Li, D., Yu, R., Chen, J., Leng, X., Zhao, D., Jia, H., An, S. (2022). Ecological risk of heavy metals in lake sediments of China: A national-scale integrated analysis. *Journal of Cleaner Production*, 334,1-12.

- Ma, L., Han, C. (2019). Water quality ecological risk assessment with sedimentological approach. Intech. <https://doi.org/10.5772/intechopen.88594>
- MacDonald, D.D., Ingersoll, C.G., Berger, T.A. (2000). Development and evaluation of consensus-based sediment quality guidelines for freshwater ecosystems, *Archives of Environmental Contamination and Toxicology*, 39,20-31.
- Manoj, K., Padhy, P.K. (2014). Distribution, enrichment and ecological risk assessment of six elements in bed sediments of a tropical river, Chottanagpur Plateau: A spatial and temporal appraisal. *Journal of Environmental Protection*, 5,1419-1434.
- Mazurek, R., Kowalska, J., Gasiorek, M., Zadrozny, P., Jozefowska, A., Zaleski, T., Kepka, W., Tymczuk, M., Orłowska, K. (2017). Assessment of heavy metals contamination in surface layers of Roztocze National Park forest soils (SE Poland) by indices of pollution, *Chemosphere*, 168, 839-850.
- Messenger, M., Lehner, B., Grill, G., Nedeva, I., Schmitt, O. (2016). Estimating the volume and age of water stored in global lakes using a geo-statistical approach. *Nat. Commun*, 7,13603.
- Müller, G., Putz, G. (1969). Index of geoaccumulation in sediments of the Rhine River. *Geojournal*, 2, 108-118.
- Proshad, R., Kormoker, T., Islam, M.S., Chandra, K. (2019). Potential health risk of heavy metals via consumption of rice and vegetables grown in the industrial areas of Bangladesh, *Hum.Ecol. Risk Assess.*, 26, 921–943.
- Rao, K., Tang, T., Zhang, X., Wang, M., Liu, J., Wu, B., Wang, P., Ma, Y. (2021). Spatial-temporal dynamics, ecological risk assessment, source identification and interactions with internal nutrients release of heavy metals in surface sediments from a large Chinese shallow lake. *Chemosphere*, 282,1-9.
- Riba, I., DelValls, T.A., Forja, J.M., Gomez Parra, A. (2002). Evaluating the heavy metal contamination in sediments from the Guadalquivir estuary after the Aznalcollar mining spill (SW Spain): a multivariate analysis approach, *Environmental Monitoring Assessment*, 77,191-207.
- Shu, X. and Xu, L. (2012). Urban ecological risk assessment using the sediment quality triad. The 18th Biennial Conference of the International Society for Ecological Modeling, *Procedia Environmental Sciences*, 13,854-862.
- Stefanovic, V., Trifkovic, J., Djurdjic, S., Vukojevic, V., Tesic, Z., Mutic, J. (2016). Study of silver, selenium and arsenic concentration in wild edible mushroom *Macrolepiota procera*, health benefit and risk. *Environ. Sci. Pollut. Res.* 23,22084-22098.
- Tarazona, J.V., Versonnen, B., Janssen, C., De Laender, F., Vangheluwe, M., Knight, D. (2014). Principles for Environmental Risk Assessment of the Sediment Compartment Proceedings of the Topical Scientific Workshop, Helsinki, 7-8 May 2013, 82p

- USEPA, (1986). Superfund Public Health Evaluation Manual; U.S. Environmental Protection Agency: Washington, DC, USA,1-86.
- USEPA, (1989). Human Health Evaluation Manual. In Risk Assessment Guidance for Superfund; EPA/540/1-89/002; Office of Emergency and Remedial Response, U.S. Environmental Protection Agency: Washington, DC, USA,Volume 1.
- USEPA, (1992). Framework for Ecological Risk Assessment. EPA/630/R- 92/001.
- USEPA, (1997). Exposure Factors Handbook; EPA/600/P-95/002F; National Center for Environmental Assessment, US EPA Office of Research and Development: Washington, DC, USA.
- USEPA, (1998). Guidelines for Ecological Risk Assessment. EPA/630/R - 95/002F.
- USEPA, (2001). Baseline Human Health Risk Assessment Vasquez Boulevard and I-70 Superfund Site Demver, Co; U.S. Environmental Protection Agency: Washington, DC, USA.
- USEPA, (2020a). Exposure Assessment Tools by Media - Water and Sediment. Accessed date: <https://www.epa.gov/expobox/exposure-assessment-tools-media-water-and-sediment> (Accessed 12 December 2022).
- USEPA, (2020b). Regional Screening Levels (RSLs)-Equations. Accessed date: <https://www.epa.gov/risk/regional-screening-levels-rsls-equations>. (Accessed 12 December 2022).
- USEPA, (2020c). Regional Screening Levels (RSLs)-User's Guide. <https://www.epa.gov/risk/regional-screening-levels-rsls-users-guide>, Accessed date: 08 February 2020.
- USEPA, (2020d). Regional Screening Level (RSL) Summary Table (TR=1E-06 THQ=1.0). <https://semspub.epa.gov/work/HQ/197414.pdf>, Accessed date: 08 February 2020.
- Ustaoğlu, F., Aydın, H. (2020). Health risk assessment of dissolved heavy metals in surface water in a subtropical rivers basin system of Giresun (north-eastern Turkey). *Desalination and Water Treatment*, 194, 222-234.
- Varol, M., Ustaoğlu, F., Tokatlı, C. (2022). Ecological risks and controlling factors of trace elements in sediments of dam lakes in the Black Sea Region (Turkey). *Environ. Res.* 205,112478.
- Vasiliu, D., Bucse A., Lupascu, N., Ispas, B., Gheablau, C., Stanescu, I. (2020). Assessment of the metal pollution in surface sediments of coastal Tasaul Lake (Romania). *Environ Monit Assess*, 192,749,1-16.
- Waara, S., Johansson, F. (2022). Ecological risk assessment of trace elements accumulated in stormwater ponds within industrial areas. *Environmental Science and Pollution Research*, 29, 27026-27041.
- Wang, X., Zhang, L., Zhao, Z., Cai, Y. (2018). Heavy metal pollution in reservoirs in the hilly area of southern China: distribution, source apportionment and

- health risk assessment. *Sci.Total Environ*, 634,158-169.
- Wei, L., Cai, M., Du, Y., Tang, J., Wu, Q., Xiao, T., Luo, D., Huang, X., Liu, Y., Fei, Y., Chen, Y. (2019). Spatial attenuation of mining/smeltingderived metal pollution in sediments from tributaries of the Upper Han River, China. *Mine Water Environ*, 38,410-420.
- Wu, Y. H., Liu, E.F., Yao, S.C., Zhu, Y.X., Xia, W.L. (2010). Recent heavy metal accumulation in Dongjiu and Xijiu lakes, East China. *J. Paleolimnol*, 43,385-392
- Yang, J., Wang, W., Zhao, M., Chen, B., Dada, O.A., Chu, Z. (2015). Spatial distribution and historical trends of heavy metals in the sediments of petroleum producing regions of the Beibu Gulf, China. *Mar Pollut Bull*, 91,87-95.
- Yu, Z., Liu,E., Lin, Q., Zhang, E., Yang, F.,Wei, C., Shen, J. (2021). Comprehensive assessment of heavy metal pollution and ecological risk in lake sediment by combining total concentration and chemical partitioning. *Environmental Pollution*, 269,1-11.
- Zhang, L., Ye, X., Feng, H., Jing, Y., Ouyang, T., Yu, X., Liang, R., Gao, C., Chen, W. (2007). Heavy metal contamination in western Xiamen Bay sediments and its vicinity, China. *Marine Pollution Bulletin*, 54(7), 974-982.
- Zheng, X.; Zhao, W.; Yan, X.; Shu, T.; Xiong, Q.; Chen, F. (2015). Pollution characteristics and health risk assessment of airborne heavy metals collected from beijing bus stations. *Int. J. Environ. Res. Public Health*, 12, 9658-9671.
- Zhuang, S., Lu, X., Yu, B., Fan, X., Yang, Y. (2021). Ascertain the pollution, ecological risk and source of metal(loid)s in the upstream sediment of Danjiang River, China. *Ecological Indicators*, 125,1-12.
- Zhu, A., Liu, J., Qiao, S., Zhang, H. (2020). Distribution and assessment of heavy metals in surface sediments from the Bohai Sea of China. *Mar. Pollut. Bull.*, 153,110901.
- Zhuang, S., Lu, X. (2020). Environmental risk evaluation and source identification of heavy metal(loid)s in agricultural soil of Shangdan valley, northwest China. *Sustainability*, 12,5806.



## ***CHAPTER 10***

### **ENRICHMENT OF VERMICOMPOST BY PLANT GROWTH PROMOTING BACTERIA**

*Mustafa CERITOGLU<sup>1</sup>, Murat ERMAN<sup>2</sup>*

---

1 Siirt University, Faculty of Agriculture, Department of Field Crops, Siirt, Turkey

2 Uludağ University, Faculty of Agriculture, Department of Field Crops, Bursa, Turkey ceritoglu@siirt.edu.tr ORCIDs: 1\*0000-0002-4138-4579; 20000-0002-1435-1982

## INTRODUCTION

Advanced industrialization, the green revolution and anthropogenic activities are the staple problems causing environmental pollution in the last century because of their toxic impacts on the ecosystem (Chavan et al., 2021). Sewage sludge, municipal solid waste, agricultural wastes, agro-industrial wastes, food and kitchen waste, animal waste and garden waste are generally classified as solid organic wastes (Mata-Alvarez et al. 2000). Most developing countries produce a huge amount of solid waste due to lack of suitable disposal facilities and waste segregation (Ngoc and Schnitzer 2009). Solid waste management is an urgent and mandatory requirement for the sustainable functioning of societies (Bui et al., 2020). Although organic wastes, in particular animal manure, might be used as organic compost amendment in agriculture in rural areas, solid wastes are a pivotal problem in urban areas in which it is a much more expensive process (Rathore and Sarmah, 2020). Thus, approaches containing both reductions of organic wastes and converting them into a valuable organic amendment such as vermicomposting.

Vermicompost is the final product subjecting organic wastes to mesolytic degradation through the digestive system of worms, therefore, they are converted into a high-quality material. Vermicomposting contains bio-oxidative processes and stabilization of organic material due to interactions among special earthworm species and beneficial microorganisms (Ceritoglu et al., 2020; Singh et al., 2020; Vukovic et al., 2021; Makkar et al., 2022). Special earthworm species are used for the vermicomposting process. The most preferred species are *Eisenia fetida*, *Eisenia andrei*, *Lumbricus rubellus*, *Dendrobaena veneta*, *Eudrilus eugeniae* and *Perionyx excavatus* (Şahin and Ceritoglu, 2020). Vermicompost application promotes plant growth, crop yield and quality due to nutrient composition and some other growth regulators (Joshi and Vig, 2010; Şahin and Bice Ataklı, 2021; Wang et al., 2021; Zaman and Yaacob, 2022) and also enhance soil productivity (Singh et al., 2020; Nabil et al., 2022). Although vermicompost has many superior benefits compared with chemical fertilizers and many other organic amendments, nutrient availability of it is lower than synthetic fertilizers, therefore, usage of vermicompost alone might cause yield losses in the production of some crops. Thus, practices increasing the chemical composition of vermicompost products are important for sustainable agriculture and the market of vermicomposting. From this perspective, enrichment of the chemical composition of vermicompost by beneficial bacteria, i.e., plant growth promoting bacteria (PGPB) might be an effective and sustainable approach since PGPB can fix nitrogen, solubilize phosphate and potassium compounds, secrete hormones and vitamins (Orozco-Mosqueda et al., 2020; Khatoon et al., 2022; Stegelmeier et

al., 2022). This review aims to denote the enrichment of vermicompost by PGPB products and its implementation practices.

## 1. CRITICAL PRODUCTION STEPS FOR SUCCESSFUL VERMICOMPOSTING

The incubation period and implementation methods of each organic material for vermicomposting show differences. The type of organic waste for vermicomposting reveals a different quality of the product (Manaf et al., 2009; Garcia-Sanchez et al., 2017; Maharjan et al., 2022). Once cattle manure or pig manure is used, it is mixed with straw or used by removing the liquid part in order to reduce the urea level. Pig manure can be used in 2 weeks at the earliest, while cattle manure can be used within 3-5 days. The optimum time required for the compost to ferment at the optimum level is 9 days (Nair et al., 2006). This time is sufficient for the thermolytic decomposition and destruction of harmful pathogens (Chen et al., 2005; Liu and Liu, 2017; Ji et al., 2022).

Poultry manure is not preferred because it is not suitable for vermicompost production. The main reason for this is that there is a high level of ammonia in poultry manure (chicken, turkey, duck, pigeon, etc.), which has a toxic effect on worms (Tchobanoglous et al., 1993). Apart from this, industrial wastes, paper, sugar and brewery industry wastes, municipal and sewage wastes, and restaurant and garden wastes can be used as substrate material for vermicompost production (Edwards, 1995).

One of the most important steps in vermicompost production is the correct preparation of the food to be given to the worms. The food to be prepared must be subjected to fermentation. The fermentation process is to decompose the organic material. Moisture content is one of the most important aspects in the preparation and delivery of compost. Moisture is necessary for microorganisms to operate. If the moisture content falls below 40%, microbial activities decrease to a minimum level, and if it falls below 10%, it stops completely (Tchobanoglous et al., 1993). Although the optimum humidity for bacteria is 55%, worms need a little more humidity (65-75%) for optimum nutrient media (Rostami et al., 2010). In advanced systems, there are devices that show the humidity status. Moisture control with primitive methods, on the other hand, is based on the fact that the food is moist enough to stick when squeezed in the palm, but water does not come out (Ceritoglu et al., 2019).

In the production of vermicompost, the ambient temperature should be kept under control. The degree of temperature is very important for the vital activities of both bacteria and worms. Since worms have open blood circulation, their body temperature is directly affected by the ambient temperature (Mısırlıoğlu, 2017). Although the *Eisenia fetida* species has high-

er adaptability than other species, deaths occur if the temperature of the pool they are in drops to 0 °C and below. They can survive at around 7-8 °C on average, but their ability to operate is severely restricted. Although it varies according to the species, the optimum ambient temperature for their development and activities, in general, is between 15-25 °C. The optimum temperature range for microbial activities to continue at an optimum level and for organic matter to be broken down in the shortest time is 15-30 °C (Rostami et al., 2009).

The C:N ratio of the substrate material chosen to be composted is very important. High C:N ratio causes a decrease in microbial activities (Ökmen and Algur, 2000). In materials with a very low C:N ratio, excess ammonia has a toxic effect on worms (Tchobanoglous et al., 1993). For this reason, it is necessary to be careful in determining the substrate material to be selected.

Many different methods are used in the production of vermicompost. If classified, production can be made in batches or closed box systems in general. The production facility, initial cost, production purpose, workforce, or mechanization preferences are the factors affecting the installation. In production to be carried out in rows on the soil surface in the open field, the labor force is too much.

The initial setup cost is also low. However, the main thing to pay attention to here is that in places where the air temperature is low, the heap should be protected and isolated from the cold somehow. Since the production is in the open area, sterilization may also be low and unwanted insects or organisms may enter the heap. In this case, the chemical composition of the produced vermicompost changes and the product quality decreases due to contamination.

One of the most important factors in the planning of vermicompost production facilities is the cost of installation. In enterprises that are aimed to be established at low cost, facilities can be established in the form of rows set up in the open area and beds surrounded by simple walls. There is no limit to the length of the rows, but their width should not exceed 2 meters. Homogeneous and smooth workmanship opportunities are restricted in rows that will be made too wide. Vermicompost mix is laid directly on the bed. If watering is done excessively, it will not be a problem as it will run off as it is directly on the ground. Although it is the most primitive and inexpensive production method, production takes place more slowly than other methods. A disadvantage of this production method is the loss of nutrients by evaporation or leakage in humidification in hot weather (Edwards, 1995).

The name of a simple method used to increase the efficiency of the process in vermicompost production areas is “movable cover beds” (Şimşek

Erşahin, 2007). In this method, organic material is given to the surface in thin layers such as 1-2 cm and the system is supported by raising it from the sides with a movable cover. Worms are constantly fed with fresh food and the proportion of organic matter left unconsumed in the heap is minimized. These systems are generally not preferred for commercial production. However, the demand for improved systems equipped with motor and pulley systems is increasing day by day. In these systems, which are called continuous flow systems, as in other methods,

Worms such worms are fed by giving organic matter from the top. There are blades attached to the reel at the bottom of the system. As organic matter is added from above, worms flock to the top and leave the bottom layer. Production is made without loss of time and worms are not interfered with. Worms get stressed by the smallest interventions from the outside and they remain passively waiting until they feel safe. In this case, fertilizer production does not occur because the worms are not fed. Thus, it causes reductions in production speed.

For the aforementioned reasons, worms' habitats should not be interfered with as much as possible. continuous flow In the systems, mass production can be made for 2 years by only giving food without any intervention in the system.

One of the most important factors affecting the quality of vermicompost material is the drying stage. In order for the produced vermicompost not to lose its properties, it must be dried correctly. It is stated that the total nitrogen rate of the vermicompost product is 31.25% lower than the dried form with the correct methodology. It is also stated that Phosphorus and 72.86% decrease (Manyuchi et al., 2013).

Drying the vermicompost in an environment that is not exposed to direct sunlight and has ventilation is the most correct drying method. If there is a ventilation problem in the environment to be dried, the process will take a long time due to the humidity of the environment. It is recommended that the drying ambient temperature is not more than 35 °C. In addition, the optimum value for the moisture content of the vermicompost material at the end of the drying process is 50-55%. If the humidity falls below 45%, the material loses its black appearance and becomes dusty and gray. Rehydrating will not make the black color come back. This is also an indication of the decrease in the microbial activity of the material (Kakitis et al., 2017). Disease, pest, insect, etc. during drying. An environment that is isolated from dishes such as dishes should be preferred. Some factors need to be considered for the product obtained to have a high market value and to be in demand. First of all, the product obtained must be homogeneous and free from foreign substances. For this reason, it is necessary to

sift the end product with mechanization in large enterprises and with more primitive tools or methods in small enterprises.

In advanced production facilities with sterilization facilities, the vermicompost product is shipped to the packaging area immediately after the sterilization process. Vermicompost products produced for commercial purposes must be packaged and stored in order to preserve their properties, prevent foreign matter contamination, and prevent destruction by insects and harmful microorganisms. If such an opportunity is not available, an environment free from diseases, harmful bacteria and insects should be preferred for storage. Organic materials kept in an open area become the habitat of harmful microorganisms and insects.

## **2. PHYSIO-CHEMICAL AND BIOLOGICAL CHARACTERISTICS OF VERMICOMPOST**

Earthworms are fed with various organic materials or a mixture of them and provided to convert into a valuable fertilizer through their digestion system. Vermicompost has a granular structure, dark, odorless and homogeneous (Devi and Kumar, 2020). It is easy-dissolve, slow-release, and has a rich nutrient source that can be used by plants for a long time (Lim et al., 2014). Another feature that makes vermicompost valuable is the mass density. Mass density positively affects plant growth, porosity, moisture content and aeration in the soil. The high or low mass density causes inhibitory effects on the physiological properties of soils. The porosity should be between 70-80% of the total volume in a quality vermicompost product, Aeration rate in the pores should be between 20-30% and 55-75%. Atiyeh et al. (2001) indicated that it is the optimum level for plant development. Also, the moisture content should be around 50-90% in the final vermicompost product (Dominguez and Edwards, 2011).

Vermicompost has more promotive effects compared with other conventional composts (Kiyasudeen et al., 2015). Furthermore, vermicompost has nutrients in a beneficial form that can be directly taken by plants (Yatoo et al., 2021). The most critical factor affecting vermicompost is the structure of the substrate material. Vermicompost quality is determined by such factors as an increase in microbial viability, mineralization of organic matter, high humic acid fractions and breakdown of carbohydrates (Cao et al., 2021). Vermicompost contains macronutrients, vitamins, humic substances, hormones, antioxidants and enzymes (Geremu et al., 2020; Karwal and Kaushik, 2020; Kovacic et al., 2022; Yogi et al., 2022).

Substrate material (animal manure, urban wastes, vegetable wastes, etc.), ambient temperature, moisture status and earthworm species significantly affect the quality of vermicompost. Therefore, pH, electrical conductivity, C:N ratio and chemical composition of substrate material has

a pivotal role in vermicompost quality. Total C and N concentrations are higher in vermicompost compared with other compost products. The C:N ratio of substrate material in vermicomposting should be around 20-22. If it is higher than these values, the stability of the organic material is low due to the organic carbon, and it indicates that the product is not sufficient for vermicomposting.

Substrate material also alters macronutrient and micronutrient concentrations of vermicompost products. In general, total nitrogen, soluble phosphorus, soluble potassium,  $\text{Ca}^{2+}$ ,  $\text{Mg}^{2+}$ ,  $\text{Fe}^{2+}$ ,  $\text{Cu}^{2+}$  and  $\text{Mn}^{2+}$  concentration change between 0.71-3.39%, 0.33-2.6%, 1.14-3.65%, 3.51-22.8 ppm, 0.61- 6.64 ppm, 7.9-11.5 ppm, 0.89-98.3 ppm, and 275-304.3, respectively (Canellas et al., 2010; Singh and Singh, 2017; Zhu et al., 2017; Barlas et al., 2018; Lahbouki et al., 2022). Substrate material also affects EC, pH, organic carbon and alters cellulose, hemicellulose and lignin ratios. Although even the same substrate material is used in the vermicomposting, the chemical composition of the final product might be changed due to ambient temperature, humidity and microbial density (Nada et al., 2012; Moustafa et al., 2022a,b).

Combined activities of earthworms and microorganisms in vermicomposting and mesophilic degradation process provide bio-oxidation of organic matter and enriched it over conventional composts, therefore, microbial activity and population increased in vermicompost product (Fracchia et al., 2006). The influences of vermicompost on soil quality and microbial activity are investigated by many researchers using agronomic, chemical and molecular techniques, and some specific enzymes (Benitez et al., 2005; Şahin and Kurt, 2020; Ding et al., 2021; Razaei-Chiyaneh et al., 2021). Substrate materials that have a low C:N ratio are ideal for the induction of microbial populations. Because microorganisms need nitrogen for reproduction (Kumar and Shweta, 2011). Carbon source has a vital role for microorganisms. Many bacteria are fed with easy-structure C compounds whereas fungi prefer the more complex compounds (Meidute et al., 2008). Vermicompost also contributes to C mineralization. The integrated use of various organic fertilizers contributes 16-20% more to the rise of microbial activity due to the diverse requirements of different communities (González et al., 2010).

### **3. ROLE OF PLANT GROWTH PROMOTING BACTERIA IN AGRICULTURE**

PGPB is described as bacterial populations with rising water and nutrient uptake, having fixation ability of nitrogen and solubilization of phosphorus compounds for plants and promoting plant development and growth. Moreover, PGPB improves stress tolerance due to such mecha-

nisms producing phytohormones, growth regulators and vitamins, ACC deaminase enzyme activity, and suppressing pathogens by fungicidal and antibiotic compounds (Glick, 2020; Chowdhury, 2022). Ideal PGPB strains should have some criteria such as being eco-friendly, exhibiting a wide spectrum of action, high colonization, induction of plant growth, improvement to biotic and abiotic stress factors, and high competition ability to other bacteria (Basu et al., 2021).

PGPB strains are used for biofertilizers, phytostimulators, rhizoremediators, biomodifiers, stress bioalleviators, and control agents (Ma et al., 2016). PGPB strains are isolated and characterized from the natural flora since each strain has different superior characteristics and researchers focus on target properties for selection. In general, PGPB strains that have superior properties involve genera such as *Acetobacter*, *Acinetobacter*, *Achromobacter*, *Aereobacter*, *Agrobacterium*, *Alcaligenes*, *Artrobacter*, *Azospirillum*, *Azotobacter*, *Bacillus*, *Burkholderia*, *Clostridium*, *Enterobacter*, *Erwinia*, *Flavobacterium*, *Klebsiella*, *Micrococcus* and *Pseudomonas* (Çakmakçı, 2005; Etesami and Adl, 2020). PGPB strains have direct and indirect mechanisms containing plant growth and protection due to biochemical and molecular pathways (Vejan et al., 2016; Glick, 2020).

Many researchers indicated that PGPB applications promoted plant growth and increased yield and quality in different crops. Solanki et al. (2020) determined that the application of PGPB promoted the number of branches, plant height, nodule dry weight, number of nodules, number of pegs, number of total pods, number of mature pods, test weight, shelling percentage, pod yield, protein content and haulm yield in groundnut. Tahir et al. (2018) reported that PGPB enhanced the performance of *Triticum aestivum* under an arid climate and low fertilizer conditions. EL Maaloum et al. (2020) denoted that PGPB consortia increased dry matter accumulation in shoots and roots by 239% and 395%, respectively. Similarly, promotive effects of PGPB applications were determined by Sedri et al (2022) in wheat, Slimani et al. (2022) in barley, Siddique et al. (2007) in lentil, Hafez et al. (2021) in faba bean, Filiz et al. (2021) in bean, Notununu et al. (2022) in maize, Samet et al. (2022) in potato, and Kumar et al. (2022) in medicinal plants.

#### **4. ADVANTAGES OF ENRICHED VERMICOMPOST BY PGPB AND USAGE PRACTICES**

Vermicompost is an organic material containing macro and micro nutrients, phytohormones, various microbial populations, organic matter and humic substances. It is known that vermicompost applications have positive effects on soil properties, plant growth, crop yield and quality in the short and long term. However, compared to synthetic fertilizers, the

contents of NPK nutrients are lower in vermicompost. In addition, since it is an organic fertilizer, the amount that should be given to the hectare area is high. Therefore, increasing the nutrient content in its structure can turn vermicompost into a more valuable and productive material. It has been observed in different studies that positive results can be obtained, especially by using PGPB strains that can fix nitrogen and solubilize phosphate in the vermicompost production process or add them to the final product.

Das et al. (2016) determined that enrichment of vermicompost by alone or consortia of *Trichoderma viride*, *Azotobacter chroococcum*, *Bacillus polymixa* and *Bacillus firmus* increased nitrogen, phosphorus and potassium content. Also, the best quality vermicompost was obtained with the treatment of all microorganisms together. Tensingh and Muthulaksmi (2017) enriched vermicompost product with *Pseudomonas fluorescens*, *Azospirillum brasilense* and *Bacillus megaterium* under laboratory conditions. After bacterial inoculation, researchers investigated the effects of enriched and normal vermicomposts on some germination characteristics and seedling vigor in okra (*Abelmoschus Esculentus*). Enriched vermicompost caused higher seed germination, shoot and root growth, fresh biomass and dry matter accumulation compared with normal vermicompost treatment. Mahanta et al. (2012) investigated the effects of substrate material (rice straw, *Ipomoea carnea*, *Eichhornia crassipes*, and consortia) and enrichment by PGPB strains (*Azotobacter chroococcum*, *Pseudomonas fluorescens* and *Azospirillum brasilense*) on vermicompost composition, and its effect on rice growth and soil fertility. Researchers indicated that *A. chroococcum*-enriched vermicompost increased the highest grain yield, plant growth, nitrate reductase activity and leaf chlorophyll content of rice. Also, *A. chroococcum*-enriched vermicompost improved soil C, N, P and K content of the soil after harvest higher than other microorganisms and control. Khare et al. (2018) reported that enriched vermicompost with *Azotobacter chroococcum* promoted *Aegle marmelos* and *Phyllanthus emblica* plants. Rajasekar et al. (2012) stated that microbial amendment, *Rhizobium leguminosarum* and *Azospirillum brasilense*, on the 30th day of vermicomposting was observed to maintain enough viable population in the vermicompost. Lukashe et al. (2019) determined that phosphate solubilizing PGPB can enhance the phosphate availability of vermicompost and also reduce C/N ratio from 18 to 11. In another experiment, enriched vermicompost by phosphorus solubilizing PGPB strain induced phosphorus uptake up to 20-39% in wheat and 26-53% in tomato, and promoted more plant growth under low phosphorus concentration calcareous soils (Parastesh et al., 2019). Shiraz et al. (2019) reported that using of *Halothiobacillus neapolitanus* for the enrichment of vermicompost caused increasing phosphorus (130%) and iron (45%) concentrations of vermicompost at the

end of 40 days of incubation. The addition of nitrogen-fixing *Azospirillum brasilense* to vermicomposting process increased plant growth in okra and improved soil quality after harvest (Baliah and Muthulakshmi, 2017).

### **CONCLUSION**

Vermicomposting is both an eco-friendly, effective and sustainable approach for the valorization of organic wastes and also a major organic amendment for major crops. Enrichment of vermicompost by superior PGPB strains is a cost-effective and versatile solution for increasing the chemical and biological composition of this organic material. Moreover, using of PGPB strains for the enrichment of vermicompost might be applied in both vermicomposting process and storage duration. In conclusion, PGPB strains might be used for the enrichment of vermicompost products, therefore, this can make it a more effective and useful organic fertilizer.

## REFERENCES

- Atiyeh, R.M., Edward, C.A., Subler, S., Metzger, J.D., 2001. Pig manure vermicomposts as a component of a horticultural bedding plant medium: Effects on physicochemical properties and plant growth. *Bioresource Technology*, 78(1): 11-20.
- Baliah T.N., Muthulakshmi P. (2017) Effect of microbially enriched vermicompost on the growth and biochemical characteristics of okra (*Abelmoschus esculentus* (L.) Moench). *Advances in Plants & Agriculture Research*, 6(5): 147-152.
- Barlas, N.T., Cönkeroğlu, B., Ünal, G., Bellitürk, K., 2018. The effect of different vermicompost doses on wheat (*Triticum vulgare* L.) nutrition. *Tekirdağ Ziraat Fakültesi Dergisi*, 15(2): 1-4.
- Basu, A., Prasad, P., Das, S.N., Kalam, S., Sayyed, R.Z., Reddy, M.S., El Enshasy, H., 2021. Plant growth promoting rhizobacteria (PGPR) as green bioinoculants: Recent developments, constraints, and prospects. *Sustainability*, 13(3): 1140.
- Benitez, E., Sainz, H., Nogales, R., 2005. Hydrolytic enzyme activities of extracted humic substances during the vermicomposting of a lignocellulosic olive waste. *Bioresource Technology*, 96(7): 785-790.
- Bui, T.D. Tsai, F.M. Tseng, M.-L. Ali M.H., 2020. Identifying sustainable solid waste management barriers in practice using the fuzzy Delphi method *Resour. Resources, Conservation and Recycling*, 154: 104625.
- Canellas, L.P., Piccolo, A., Dobbss, L.B., Spaccini, R., Olivares, F.L., Zandonadi, D.B., Façanha, A.R., 2010. Chemical composition and bioactivity properties of size-fractions separated from a vermicompost humic acid. *Chemosphere*, 78(4): 457-466.
- Cao, Y., Tian, Y., Wu, Q., Li, J., Zhu, H., 2021. Vermicomposting of livestock manure as affected by carbon-rich additives (straw, biochar and nanocarbon): A comprehensive evaluation of earthworm performance, microbial activities, metabolic functions and vermicompost quality. *Bioresource Technology*, 320: 124404.
- Ceritoglu, M., Erman, M., Ceritoglu, F., Bektas, H., 2020. The response of grain legumes to vermicompost at germination and seedling stages. *Legume Research*, 44(8): 936-941.
- Ceritoglu, M., Şahin, S., Erman, M., 2019. Vermikompost üretim tekniği ve üretimde kullanılan materyaller. *Türkiye Tarımsal Araştırmalar Dergisi*, 6(2): 230-236.
- Chavan, S., Yadav, B., Tyagi, R., Drogui P., 2021. A review on production of polyhydroxyalkanoate (PHA) biopolyesters by thermophilic microbes using waste feedstocks. *Bioresource Technology*, 341: 125900.

- Chen, X., Chen, S., Sun, M., Yu, Z., 2005. High yield of poly- $\gamma$ -glutamic acid from *Bacillus subtilis* by solid-state fermentation using swine manure as the basis of a solid substrate. *Bioresource Technology*, 96(17): 1872-1879.
- Chowdhury, R.A., 2022. Plant growth-promoting rhizobacteria (PGPR): Strategies to improve heavy metal stress under sustainable agriculture. In: Bandh S.A. (eds) *Sustainable Agriculture*. Springer, Cham.
- Çakmakçı, R., 2005. Use of plant growth promoting rhizobacteria in agriculture. *Atatürk Üniversitesi Ziraat Fakültesi Dergisi*, 36(1): 97-107. (In Turkish)
- Das, D., Bhattacharyya, P., Ghosh, B.C., Banik, P., 2016. Bioconversion and biodynamics of *Eisenia foetida* in different organic wastes through microbially enriched vermiconversion Technologies. *Ecological Engineering*, 86: 154-161.
- Devi, M.G., Kumar, C.H.A., 2020. Enriched vermicompost production: A success story of Guntur farmer. *Journal of Pharmacognosy and Phytochemistry*, 9(5): 891-895.
- Ding, Z., Kheir, A.M.S., Ali, O.A.M., Hafez, E.M., ElShamey, E.A., Zhou, Z., Wang, B., Lin, X., Ge, Y., Fahmy, A.E., Seleiman, M.F., 2021. A vermicompost and deep tillage system to improve saline-sodic soil quality and wheat productivity. *Journal of Environmental Management*, 277: 111388.
- Domínguez, J., Edwards, C.A., 2011. Relationships between composting and vermicomposting: Relative values of the products. In: Clive A. Edwards, Norman Q. Arancon, Rhonda L. Sherman (Eds.) *Vermiculture Technology: Arthworms, Organic Waste and Environmental Management*. CRC Press. Boca Raton, Florida.
- Edwards, C.A., 1995. Commercial and environmental potential of vermicomposting. *BioCycle*, 62-63.
- Etesami, H., Adl, S.M., 2020. Plant growth promoting rhizobacteria (PGPR) and their action mechanisms in availability of nutrients to plants. In: M. Kumar, V. Kumar, R. Prasad *Phyto-Microbiome in Stress Regulation*. Environmental and Microbial Biotechnology. Springer, Singapore.
- Filiz, O., Takıl, E., Kayan, N., 2021. The role of plant growth promoting rhizobacteria (PGPR) and phosphorus fertilization in improving phenology and physiology of bean (*Phaseolus vulgaris* L.). *Applied Ecology and Environmental Research*, 19(3): 2507-2517.
- Fracchia, L., Dohrmann, A.B., Martinotti, M.G., Tebbe, C.C., 2006. Bacterial diversity in a finished compost and vermicompost: Differences revealed by cultivation independent analyses of PCR-amplified 16S rRNA genes. *Applied Microbiology and Biotechnology*, 71: 942-952.
- Garcia-Sanchez, M., Tausnerova, H., Hanc, A., Tlustos, P., 2017. Stabilization of different starting materials through vermicomposting in a continuous-feeding system: Changes in chemical and biological parameters. *Waste Management*, 62: 33-42.

- Geremu, T., Hailu, H., Diriba, A., 2020. Evaluation of nutrient content of vermicompost made from different substrates at mechara agricultural research center on station, West Hararghe Zone, Oromia, Ethiopia. *Ecology and Evolutionary Biology*, 5(4): 125-130.
- Glick, B.R., 2020. *Beneficial Plant-Bacterial Interactions*. Springer Nature Switzerland. Cham.
- González, M., Gomez, E., Comese, R., Quesada, M., Conti, M., 2010. Influence of organic amendments on soil quality potential indicators in an urban horticultural system. *Bioresource Technology*, 101(22), 8897-8901.
- Hafez, E.M., Osman, H.S., El-Razek, U.A.A., Elbagory, M., Omara, A.E-D., Eid, M.A., Gowayed, S.M., 2021. Foliar-applied potassium silicate coupled with plant growth-promoting rhizobacteria improves growth, physiology, nutrient uptake and productivity of faba bean (*Vicia faba* L.) irrigated with saline water in salt-affected soil. *Plants*, 10(5): 894.
- Ji, J.L., Liu, S., Yang, Y., Hou, C., Zhong-Wang, Y., 2022. Co-production of biogas and humic acid using rice straw and pig manure as substrates through solid-state anaerobic fermentation and subsequent aerobic composting. *Journal of Environmental Management*, 320: 115860.
- Joshi, R., Vig, A.P., 2010. Effect of vermicompost on growth, yield and quality of tomato (*Lycopersicon esculentum* L). *African Journal of Basic & Applied Sciences*, 2(3-4): 117-123.
- Kalkitis, A., Nulle, I., Vronskis, O., 2017. Experimental study of vermicompost drying process. 16th International Scientific Conference Engineering for Rural Development, May 26, Jelgava, Latvia, pp. 1086-1092.
- Karwal, M., Kaushik, A., 2020. Co-composting and vermicomposting of coal fly-ash with press mud: Changes in nutrients, micro-nutrients and enzyme activities. *Environmental Technology & Innovation*, 18: 100708.
- Khare, N., Pathak, D.V., Kumar, M., 2018. Microbially enriched vermicompost affecting seedling and plant growth in aonla and bael. *International Journal of Current Microbiology and Applied Sciences*, 7(4): 2664-2672.
- Khatoun, Z., Huang, S., Farooq, M.A., Santoyo, G., Rafique, M., Javed, S., Gul, B., 2022. Chapter 12- Role of plant growth-promoting bacteria (PGPB) in abiotic stress management. *Mitigation of Plant Abiotic Stress by Microorganisms*, 2022: 27-272.
- Kovacik, P., Wierzbowska, J., Smolen, S., Pollakova, N., Jabbarov, Z., 2022. Weight of carrot phytomass and content of vitamin C 100 days after seeding in dependence of vermicompost quantity and earthworms (*Eisenia fetida*) in soil substrate. *Polish Journal of Environmental Studies*, 31(1): 1-11.
- Kumar, R., Sheta, S., 2011. Enhancement of wood waste decomposition by microbial inoculation prior to vermicomposting. *Bioresource Technology*, 102(2): 1475-1480.

- Kumar, R., Swapnil, P., Meena, M., Selpair, S., Yadav, B.G., 2022. Plant growth-promoting rhizobacteria (PGPR): Approaches to alleviate abiotic stresses for enhancement of growth and development of medicinal plants. *Sustainability*, 14: 15514.
- Lahbouki, S., Ben-Laouane, R., Outzourhit, A., Meddich, A., 2022. The combination of vermicompost and arbuscular mycorrhizal fungi improves the physiological properties and chemical composition of *Opuntia ficus-indica* under semi-arid conditions in the field. *Arid Land Research and Management*. <https://doi.org/10.1080/15324982.2022.2115952>
- Lim, S.L., Wu, T.Y., Lim, P.N., Shak, K.P.Y., 2014. The use of vermicompost in organic farming: overview, effects on soil and economics. *Journal of the Science of Food and Agriculture*, 95(6): 1143-1156.
- Liu, E., Liu, S., 2017. Process optimization and study of biogas fermentation with a mixture of duck manure and straw. *Renewable and Sustainable Energy Reviews*, 72: 439-444.
- Lukashe, N.S., Mupambwa, H.A., Green, E., Mnkeni, P.N., 2019. Inoculation of fly ash amended vermicompost with phosphate solubilizing bacteria (*Pseudomonas fluorescens*) and its influence on vermi-degradation, nutrient release and biological activity. *Waste Management*, 83: 14-22.
- Ma, Y., 2019. Seed coating with beneficial microorganisms for precision agriculture. *Biotechnology Advances*, 37: 107423.
- Mahanta, K., Jha, D.K., Rajkhowa, D.J., Kumar, M., 2012. Microbial enrichment of vermicompost prepared from different plant biomasses and their effect on rice (*Oryza sativa* L.) growth and soil fertility. *Biological Agriculture & Horticulture*, 28(4): 241-250.
- Maharjan, K.K., Noppradit, P., Techato, K., 2022. Suitability of vermicomposting for different varieties of organic waste: A systematic literature review (2012–2021). *Organic Agriculture*, 12: 581-602.
- Makkar, C., Singh, J., Parkash, C., Singh, S., Vig, A.P., Dhaliwal, S.S., 2022. Vermicompost acts as bio-modulator for plants under stress and non-stress conditions. *Environment, Development and Sustainability*. <https://doi.org/10.1007/s10668-022-02132-w>
- Manaf, L.A., Che, M.L., Yusoff, M.K., Ismail, T.H.T., Harun, R., Juahir, H., 2009. Influences of bedding material in vermicomposting process. *International Journal of Biology*, 1(1): 81-91.
- Manyuchi, M.M., Phiri, A., Muredzi, N., Chirinda, N., 2013. Effect of drying on vermicompost macronutrient composting. *International Journal of Inventive Engineering and Science*, 1(10): 1-3.
- Mata-Alvarez, J., Mace, S., Llabres, P., 2000. Anaerobic digestion of organic solid wastes. An overview of research achievements and perspectives. *Biore-source Technology*, 74(1): 3-16.

- Meidute, S., Demoling, F., Baath, E., 2008. Antagonistic and synergistic effects of fungal and bacterial growth in soil after adding different carbon and nitrogen sources. *Soil Biology and Biochemistry*, 40(9): 2334-2343.
- Moustafa, Y.T.A., Moustafa, A., Mustafa, N.S.A., El-Dahshouri, M., El-Sawy, S.M., Haggag, L., Zhang, L., Zuhair, R., 2022. Role of vermicompost types (fish sludge and cow dung) in improving agronomic behavior and soil health of tomato crop. *Asian Journal of Plant Sciences*, 22(1): 1-12.
- Moustafa, Y.T.A., Mustafa, N.S.A., El-Dahshouri, M., Ghonim, S.T.M.E., Zuhair, R., Zhang, L., Hassoub, M.A., 2022. Influence of wastes of taro leaf, sugar beet and saw dust on physiochemical parameters of produced vermicompost. *Asian Journal of Soil Science and Plant Nutrition*, 8(3): 29-40.
- Mustafa, N.S.A., El-Dahshouri, M.F., Khoudair, A.A., Zuhair, R., Zhang, L., Moustafa, Y.T.A., Shaarawy, H.H., 2022. Effect of integration vermicompost and nano-fertilizer on fig seedlings growth and soil health. *Journal of Agriculture and Ecology Research International*, 23(6): 147-157.
- Nada, W.M., Van Rensburg, L., Claassens, S., Blumenstein, O., Friedrich, A., 2012. Evaluation of organic matter stability in wood compost by chemical and thermo-gravimetric analysis. *International Journals of Environmental Research*, 6(2): 425-434.
- Nair, J., Sekiozoic, V., Anda, M., 2006. Effect of precomposting on vermicomposting of kitchen waste. *Bioresource Technology*, 97(16): 2091-2095.
- Ngoc, U.N., Schnitzer, H., 2009. Sustainable solutions for solid waste management in Southeast Asian countries. *Waste Management*, 29(6): 1982-1995.
- Notununu, I., Moleleki, L., Roopnarain, A., Adeleke, R., 2022. Effects of plant growth-promoting rhizobacteria on the molecular responses of maize under drought and heat stresses: A review. *Pedosphere*, 32(1): 90-106.
- Orozco-Mosqueda, C., Glick, B., Santoyo, G., 2022. ACC deaminase in plant growth-promoting bacteria (PGPB): An efficient mechanism to counter salt stress in crops. *Microbiological Research*, 235: 126439.
- Parastesh, F., Alikhani, H.A., Etesami, H., 2019. Vermicompost enriched with phosphate-solubilizing bacteria provides plant with enough phosphorus in a sequential cropping under calcareous soil conditions. *Journal of Cleaner Production*, 221: 27-37.
- Rajasekar K., Daniel T., Karmegam N. (2012) Microbial enrichment of vermicompost. *ISRN Soil Science*, 2012: 946079.
- Rathore, P. Sarmah S.P., 2020. Economic, environmental and social optimization of solid waste management in the context of circular economy. *Computers & Industrial Engineering*, 145: 106510.
- Razaei-Chiyaneh, E., Amirnia, R., Chiyaneh, S.F., Maggi, F., Barin, M., Razavi, B.S., 2021. Improvement of dragonhead (*Dracocephalum moldavica* L.) yield quality through a coupled intercropping system and vermicompost

- application along with maintenance of soil microbial activity. *Land Degradation & Development*, 32(9): 2833-2848.
- Samet, M., Ghazala, I., Karray, F., Abid, C., Chiab, N., Nouri-Ellouz, O., Sayadi, S., Gargouri-Bouزيد, R., 2022. Isolation of bacterial strains from compost teas and screening of their PGPR properties on potato plants. *Environmental Science and Pollution Research*, 29: 75365-75379.
- Sedri, M.H., Niedbała, G., Roohi, E., Niazian, M., Szulc, P., Rahmani, H.A., Feiziasl, V., 2022. Comparative analysis of plant growth-promoting rhizobacteria (PGPR) and chemical fertilizers on quantitative and qualitative characteristics of rainfed wheat. *Agronomy*, 12: 1524.
- Shiraz, S.R., Jalili, B., Bahmanyar, M.A., 2019. Amendment of vermicompost by phosphate rock, steel dust, and *Halothiobacillus neapolitanus*. *Waste and Biomass Valorization*, 13: 1-7.
- Siddiqui, Z.A., Baghel, G., Akhtar, M.S., 2007. Biocontrol of *Meloidogyne javanica* by *Rhizobium* and plant growth-promoting rhizobacteria on lentil. *World Journal of Microbiology and Biotechnology*, 23: 435-441.
- Singh, A., Karmegam, N., Singh, G.S., Bhadauria, T., Chang, S.W., Awasthi, M.K., Sudhakar, S., Arunachalam, K.D., Biruntha, M., Ravindran, B., 2020. Earthworms and vermicompost: an eco-friendly approach for repaying nature's debt. *Environmental Geochemistry and Health*, 42: 1617-1642.
- Singh, A., Kumar, V., Verma, S., Majumdar, Sarkar, S., 2020. Significance of vermicompost on crop and soil productivity: A review. *International Journal of Chemical Studies*, 8(5): 1529-1534.
- Singh, A., Singh, G.S., 2017. Vermicomposting: A sustainable tool for environmental equilibria. *Environmental Quality Management*, 27(1): 23-40.
- Slimani, A., Raklami, A., Oufdou, K., Meddich, A., 2022. Isolation and characterization of PGPR and their potential for drought alleviation in barley plants. *Gesunde Pflanzen*. <https://doi.org/10.1007/s10343-022-00709-z>
- Stegelmeier, A.A., Rose, D.M., Joris, B.R., Glick, B.R., 2022. The use of PGPB to promote plant hydroponic growth. *Plants*, 11(20): 2783.
- Şimşek Erşahin, Y., 2007. Vermikompost ürünlerinin eldesi ve tarımsal üretimde kullanım alternatifleri. *Gaziosmanpaşa Üniversitesi Ziraat Fakültesi Dergisi*, 24(2): 99-107.
- Şahin, S., Bice Ataklı, S., 2021. Effects of vermicompost and mycorrhiza applications on seedling growth of cowpea in lime soil. *Turkish Journal of Agriculture - Food Science and Technology*, 9: 2659-2662.
- Şahin, S., Ceritoglu, M. (2020). A critical step towards vermicompost production: Choosing appropriate earthworm species. In: *Theory and Research in Agriculture, Forestry and Aquaculture Science*. Gece Publishing, Ankara.
- Şahin, S., Kurt, H., 2020. Effects of vermicompost applications on growth and phosphorus uptake of maize plants (*Zea Mays* L.). *Fresenius Environmen-*

tal Bulletin, 29, 11216-11222.

- Tchobanoglous, G., Theisen, H. and Vigil, S.A., 1993. Integrated Solid Waste Management: Engineering Principle and Management Issue. McGraw Hill Inc., New York.
- Tensingh, B.N., Muthulakshmi, P., 2017. Effect of microbially enriched vermicompost on the growth and biochemical characteristics of okra (*Abelmoschus Esculentus* (L.) Moench). *Advances in Plants & Agriculture Research*, 6(5): 00228.
- Wang, F., Eang, X., Song, N., 2021. Biochar and vermicompost improve the soil properties and the yield and quality of cucumber (*Cucumis sativus* L.) grown in plastic shed soil continuously cropped for different years. *Agriculture, Ecosystems & Environment*, 315: 107425.
- Vejan, P., Abdullah, R., Khadiran, T., Ismail, S., Boyce, A.N., 2016. Role of plant growth promoting rhizobacteria in agricultural sustainability - a review. *Molecules*, 21: 573.
- Vukovic, A., Velki, M., Ečimović, S., Vuković, R., Štolfa Čamagajevac, I., Lončarić, Z., 2021. Vermicomposting-facts, benefits and knowledge gaps. *Agronomy*, 11(10): 1952.
- Yatoo, A.M., Ali, N., Baba, Z.A., Hassan, B., 2021. Sustainable management of diseases and pests in crops by vermicompost and vermicompost tea. A review. *Agronomy for Sustainable Development*, 41: 7.
- Yogi, S., Khune, V.N., Bhagat, V., Singh, N., Pathak, R., Bhagat, S., Soni, A., 2022. A review on vermicompost enrichment: In prospect of village level. *Asian Journal of Agricultural Extension, Economics & Sociology*, 40(1): 104-109.
- Zaman, A.M.K., Yaacob, J.S., 2022. Exploring the potential of vermicompost as a sustainable strategy in circular economy: improving plants' bioactive properties and boosting agricultural yield and quality. *Environmental Science and Pollution Research*, 29, 12948-12964.
- Zhu, W., Du, W., Shen, X., Zhang, H., Ding, Y., 2017. Comparative adsorption of  $Pb^{2+}$  and  $Cd^{2+}$  by cow manure and its vermicompost. *Environmental Pollution*, 227: 89-97.





## **CHAPTER 11**

### **SILICON FERTILIZATION TO OVERCOME BIOTIC AND ABIOTIC STRESS FACTORS**

*Elif ÖZDEMİR<sup>1</sup>*

---

<sup>1</sup> Dr. Öğr. Üyesi, Selçuk Üniversitesi, Ziraat Fakültesi, Tarla Bitkileri Bölümü,  
Kampüs, Konya, 0000-0003-3153-1739

## 1. Introduction

Plants cannot avoid the stress factors by changing their location in their growing areas, so they must be equipped with efficient methods to detoxify or tolerate abiotic stress factors like drought, salinity, and extreme heat. Biotic and abiotic stress factors affect the growth, development and reproduction of plants and cause decreases in yield (Fig. 1).

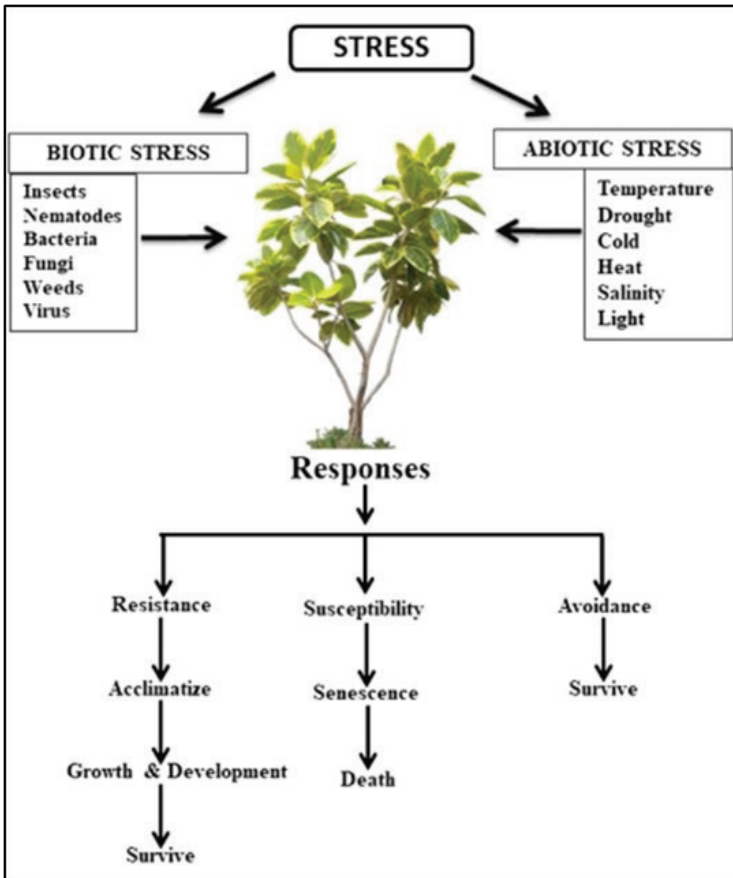

**Figure 1.** Biotic and abiotic stressors and the responses of plants against them (Baweja & Kumar, 2020)

Nowadays, it has been understood that plants activate many mechanisms in tolerance to abiotic stresses, such as molecular mechanisms, signalling, transcription, transcript processing, translation, and protein modifications (Fig. 2). These findings are extremely important for maintaining yield and stability in agricultural production under stress conditions (Zhang, Zhu, Gong, & Zhu, 2022).

Fertilizers are one of the most important inputs of farming as they protect soil fertility and support agricultural production by increasing yield and reveals the growth potential of the plant and obtaining optimum efficiency in agricultural production. The fertilization process also helps to prevent one – way exploitation of natural resources (Xie, Song, Xu, Shao, & Song, 2014).

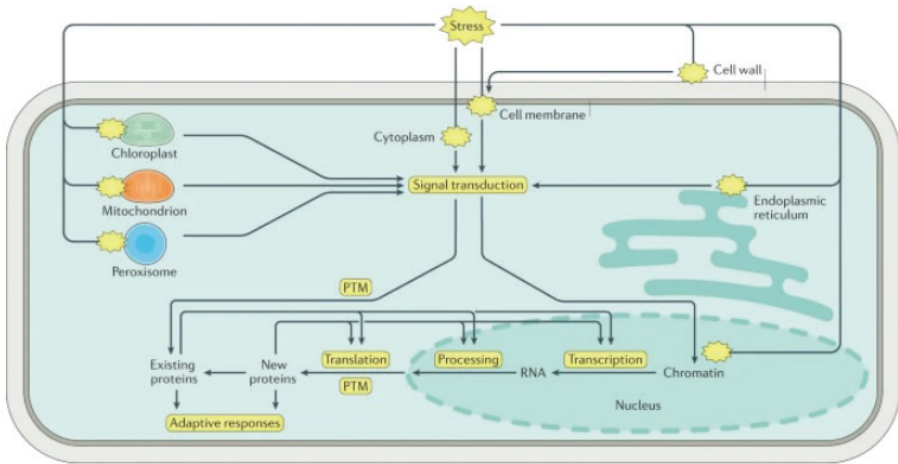

**Figure 2.** Reactions of plants against biotic and abiotic stressors (Zhang et al., 2022)

Silicon (Si) is one of the most abundant elements in the earth’s crust, but it is mostly inert and very poorly soluble (Xie et al., 2014). Nowadays, the importance of determining the appropriate silica source is increasing in Si fertilization for plant growth promotion (Suriyaprabha et al., 2012).

Although soils are rich in Si, it cannot be completely absorbed by most plants. Today, citrate and water – soluble Si fertilizers are used in China. The citrate – soluble Si fertilizer is insoluble in water, but soluble in acid and can be absorbed by plants immediately after application. The water – soluble Si fertilizers can be directly absorbed by plants after dissolving, whereas they are expensive and produced in low quantities (Horuz, Akinoğlu, & Akorkmaz, 2017).

It is also known that microorganisms play an important role in the decomposition of silicate minerals. Silicate may be converted into a form that can be absorbed by plants by silicate – dissolving bacteria in the soil, this situation supports abiotic stress tolerance of crops in some regions of the world (Santi & Mulyanto, 2018).

It has been reported that transpiration and antioxidant activity increase under water stress with Si application (Fig. 3). Numerous studies

conducted in laboratory, greenhouse and field conditions highlighted that Si fertilizers are beneficial for cereals and may be important in sustainable cereal farming (Suriyaprabha et al., 2012).

➤ Although Si is not essential for higher plants, it supports plant growth (Xie et al., 2014).

➤ Silicon is effective in alleviating various biotic and abiotic stress factors.

➤ Silicon increases the resistance of plants against pathogenic fungi and protects plants against various insects (Vaculík, Lux, Luxová, Tanimoto, & Lichtscheidl, 2009).

➤ Silicon plays a key role in improving the ability of plants withstanding biotic and abiotic stresses such as diseases and pest damages, heavy metal (Al, Mn, and Fe) toxicity, salinity, drought, and low temperature (Kaya, Tuna, & Higgs, 2006; Xie et al., 2014).

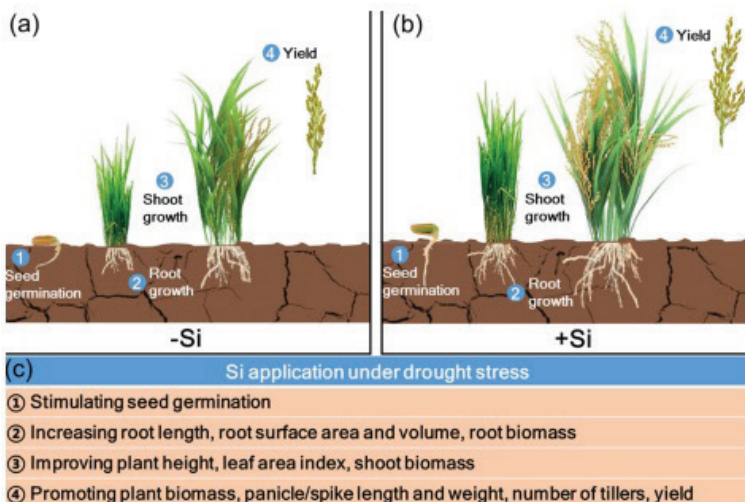

**Figure 3.** Effects of Si treatment to drought tolerance of plants (M. Wang et al., 2021)

Silicon provides an increase in the effective leaf area, photosynthetic efficiency, as well as the delay of leaf aging. Photosynthesis is an important factor for high yield in plant production also is the most basic and critical process related to maximum yield. Yield can be increased by 50% due to inducing photosynthetic capacity (Xie et al., 2014).

It is a common view that the beneficial effects of Si on plant growth are observed especially under stress conditions. Silicon application is a

practical method that can be used for increasing yield in arid conditions. It is effective in saving irrigation water as it increases tolerance to drought. Since silicone forms a physico – mechanical barrier in the epidermal cell walls and vascular tissues of the stem, pods, leaves and bark, it also prevents water loss by non – stomal way (Santi & Mulyanto, 2018).

Some effects of Si under stressors are listed below (Santi & Mulyanto, 2018).

- It supports plant growth and development.
- It provides increase in yield.
- It provides drought tolerance by decreasing water requirement.
- It helps decreasing pesticide usage by forming a physico – mechanical barrier in plant tissues.
- It supports environmentally friendly farming.

## 2. Metal Toxicity

Pollution of the environment with toxic heavy metals due to anthropogenic activities is one of the main global environmental and human health problems. Phosphate fertilizers are extremely toxic to living cells even at low concentrations (Y. Liang, Wong, & Wei, 2005).

It has been noted that Si can prevent Al toxicity in plants, soil, and solution cultures. In the presence of Si, Al – Si complexes are formed, this formation reduces the free Al uptake from the soil. In addition to this information, it has been reported that Al – Si interactions in the plants also play a role in the prevention of Al toxicity. It was observed that Si formed precipitate with Al in the epidermal cells of *Sorghum bicolor* (Fig. 4). The effect of Si on the anion – cation balance in the plants and the healing effects of Si towards Al toxicity also revealed the positive effects of Si (Corrales, Poschenrieder, & Barceló, 1997). It has also been determined that Si prevents Al toxicity in sorghum and wheat, and Mn toxicity in rice (Vaculík et al., 2009).

Cadmium (Cd) is one of the most toxic trace elements. It ranks 7<sup>th</sup> among the top 20 toxins (Dresler, Wójcik, Bednarek, Hanaka, & Tukiendorf, 2015). It is a food contaminant and contact the human body as a cumulative poison through the food chain. It also causes many environmental problems in agricultural areas of many countries and results in food safety issues. Cadmium results reduced growth of plants and causes cell death and whole plant destruction in high concentrations (Vaculík et al., 2009).

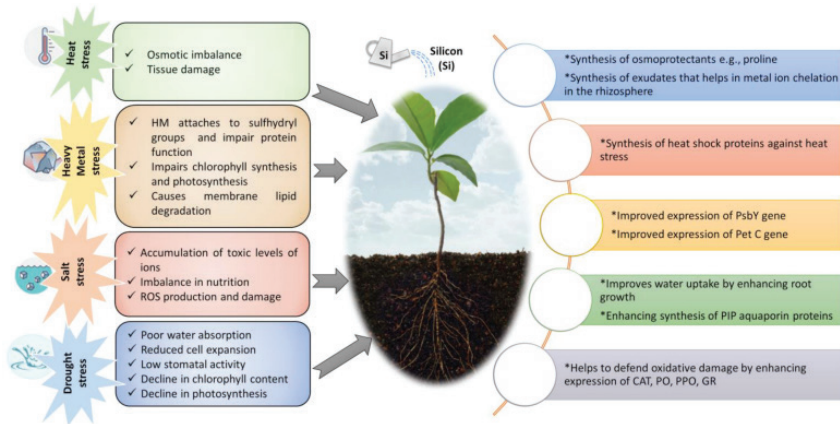

**Figure 4.** Effects of abiotic stress factors on plants and ways of Si treatment to protect them from the detrimental effects of stressors (Mir et al., 2022)

Cadmium is easily absorbed by plants. In higher plants, excess Cd causes chlorosis and necrosis in leaves, reduces nutrient uptake, retards growth and has a devastating effect on important physiological processes (Dresler et al., 2015). Cadmium significantly inhibits plant growth and impairs the uptake of nutrients. However, it causes the breakdown of chlorophyll and causes the death of the plant by inhibiting photosynthesis with the inactivation of the enzymes involved in  $\text{CO}_2$  fixation. It has also been reported that Cd toxicity induces oxidative damage characterized by accumulation of lipid peroxides and oxidized proteins as a result of inhibition of antioxidant systems in plants (Y. Liang et al., 2005).

It was reported that Si may increase the resistance / tolerance of Al, Mn toxicity and salinity although it is not an essential element for higher plants (Y. Liang et al., 2005).

Studies have shown that Si increases the accumulation of Cd in the endodermis of rice seedling roots, thereby restricting the transport of Cd to shoots and blocking the apoplasmic transport of Cd.

Silicon was effective in preventing excessive Cd uptake into Cd – treated strawberry plants; it has therefore been hypothesized that Si increases the firmness and stiffness of the cell walls, which creates a natural mechanical barrier for Cd ions. Although several studies suggest that Cd toxicity is attenuated through interaction with Si, the mechanisms involved are still poorly understood (Dresler et al., 2015).

Recently, researchers reported that Si reduces metal toxicity in some plants such as *Oryza*, *Zea mays*, soybean, and *Hordeum*. The role of Si in plant resistance against heavy metal stress is explained by the accumu-

lation of Si in the cell walls of roots, leaves and stems. The formation of heavy metal – silicate complexes in the cytoplasm and nuclei may be part of the Al or Zn tolerance mechanism (Dresler et al., 2015).

### 3. Drought

Increasing urbanization and the decrease in accessible water resources pose a threat to the sustainability of plant production. Agricultural production is significantly affected by abiotic stress factors. Drought is one of the most important abiotic stress factors limiting plant growth and productivity (Sah, Reddy, & Li, 2022). Its impact is increasing day by day due to global warming. About one – third of the world's land area is prone to drought (Santi & Mulyanto, 2018).

Lack of water negatively affects many physiological processes in plants. Plant growth and reproduction are adversely affected by water stress and other environmental stresses. In plants, responses to water stress involve different mechanisms, ranging from stomatal closure to increased root / stem ratio, decreased leaf area, and osmotic regulation (Fig. 5). In the physiological mechanism of drought avoidance, the maintenance of water potential in plants is achieved through control of stomatal conductivity or high root activity (Kaya et al., 2006).

Drought and salinity cause some changes in plants as followed,

- Ion toxicity (Thorne, Hartley, & Maathuis, 2020),
- Decline in growth and development (Thorne et al., 2020),
- Nutrient imbalance (Thorne et al., 2020),
- Oxidative damage (Thorne et al., 2020),
- Cell wall expansion (Thorne et al., 2020),
- Corruption in gene regulation and protein synthesis (Thorne et al., 2020),
- Osmotic imbalance (Thorne et al., 2020),
- Inactivation of PSI and PSII (Thorne et al., 2020),
- Disruption of photosynthesis (Thorne et al., 2020),
- Disruption of inorganic nutrient uptake and cell biosynthesis (Thorne et al., 2020),
- Changing metabolic and physiologic balances (Santi & Mulyanto, 2018),
- Imbalance in emergence and growth (Santi & Mulyanto, 2018),
- Decreasing turgor and closing stomata (Santi & Mulyanto, 2018),

➤ Disruption of photosynthetic apparatus because of visible UV or radiation (Santi & Mulyanto, 2018).

Drought and salinity cause oxidative stress resulting in the production of reactive oxygen species (ROS). Plants produce enzymatic (SOD, CAT etc...) and non – enzymatic antioxidants to be protected from the negative effects of oxidative damage (Sade, Soylu, & Yetim, 2011; Thorne et al., 2020).

It has been reported that Si applications protect plants from the negative effects of drought. In some studies, it has been noted that Si treatments reduce the negative effects of oxidative stress and promote tolerance to biotic and abiotic stress (Santi & Mulyanto, 2018).

Silicic acid concentration in the soil varies between 0.1 – 0.6 mM. Soil type, temperature, organic matter, soil pH and texture have a significant effect on available Si. Plants can take Si in the form of mono – silicic acid, solid, amorphous, or combined with water from the root to the stem in the passive and active way. Silicon is transported in the plant via the xylem and remains unpolymerized, not mobilized again when stored in different forms (Sah et al., 2022).

Silicon forms a double – layered silica cuticle complex under the leaf epidermis, reducing water loss by cuticular transpiration. Silicon – rich plants have stronger cell walls. Studies have shown that Si application promotes the growth and development of plants under abiotic stress conditions such as drought, salinity and heavy metal toxicity (Sah et al., 2022).

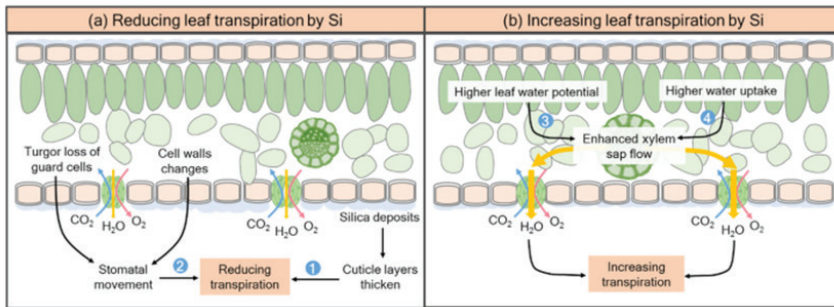

**Figure 5.** Effects of Si to transpiration mechanism of plants under drought (M. Wang et al., 2021)

In some studies, conducted with sorghum, it has been noted that sorghum with higher Si concentrations are more drought tolerant (Vaculík et al., 2009). In some studies, it has been reported that the positive effects of

Si on the drought tolerance of sorghum and maize are due to increasing the water uptake ability and water use effects of plants.

- Silicon applications have been noted to significantly increase sorghum root growth in arid conditions (Sah et al., 2022).
- Gong, Chen, Chen, Wang, and Zhang (2003) reported that Si treatment increased the water use efficiency in wheat (Saud et al., 2014).
- Gao, Zou, Wang, and Zhang (2006) stated that Si balance stomatal movement and decrease transpiration under drought (Saud et al., 2014).
- Hattori et al. (2005) recorded that Si support root growth of sorghum under water restricted conditions (Saud et al., 2014).
- Saud et al. (2014) stated that Si triggers growth and development of *Monocotyledons* that are known as Si accumulators under drought.

#### **4. Emergence and Seedling**

Seed germination is usually the most important step during seedling formation. However, this process can be delayed or completely prevented by stressors as salinity and drought. In arid and semi – arid regions, lack of water is one of the main factors limiting seed germination and crop production (Shi et al., 2014).

Application of exogenous agents may be a viable way to increase seed germination under stress conditions (Shi et al., 2014). It supports rapid germination, homogeneous and strong seedling formation.

Silicon, which can also be applied exogenously, positively affects seed strength, seedling relative growth rate and seedling dry weight, thereby increasing yield and quality (Sun et al., 2021). However, until now, little information is available about the effects of Si on seed germination under drought conditions.

Many studies have been conducted with plants that are Si accumulators, there are doubts as whether the positive responses to stress are due directly to the application of Si, because Si – rich plants already have rich Si barriers (Shi et al., 2014). For this reason, it is thought that it is necessary to work with plants that are not Si accumulators to determine the effects of Si on germination, especially in arid conditions.

#### **5. Salinity**

The surviving and growing of plants under salt stress is based on the interaction between morpho – physiological and metabolic changes in plants (Fig. 6). These adaptation mechanisms depend on the intensity

and duration of the stress factor, the plant species, genotypes, and the developmental period of the plants. Salt prevents the plant water absorbing because of osmotic pressure that occurs in the root zone, or the rapidly increasing salt concentration in the symplasm causes toxic ion effect due to the inability to retain salt ions that causes damage in the plant (Borrelli et al., 2018).

Salt is a mineral that has negative effects on plant growth and development and significantly reduces yield. Nowadays, various methods are used to prevent the negative effects of salt stress on plants. Silicone application is one of the promising methods used to prevent salt stress (S. Wang et al., 2015).

Silicon accumulates in the cell walls of leaves, reducing transpiration, which reduces  $\text{Na}^+$  uptake from the soil solution (Yin, Wang, Li, Tanaka, & Oka, 2013). Some researchers have reported that Si mediates some metabolic processes by regulating the ion balance, thus reducing the accumulation of  $\text{Na}^+$ , and in addition to these functions, it also participates in the regulation of polyamine metabolism (S. Wang et al., 2015).

When plants are exposed to salinity, they close their stomata with the decrease of hormone production in shoots and roots, thus reducing the rate of photosynthesis. In the later stages of salinity, increasing  $\text{Na}^+$  in the leaves inhibits photosynthetic enzymes, decreases the chlorophyll content, and consequently begins to restrict photosynthesis from different aspects (Borrelli et al., 2018).

Accumulation of salt as organic granular structures in the cytoplasm of some halophytes is one of the salt adaptation mechanisms. These organic granular salts isolated from halophyte plants, were analyzed and it was determined that they contained 3%  $\text{SiO}_2$ . These findings raise the question of whether Si has anything to do with salinity.

It was determined that *Halocnemum strobilaceum* and *Juncus rigidus* species grown in the Qattara region of Egypt, which are known for their salt tolerance, contain 5.4% and 2.1% Si in their tissues, respectively.

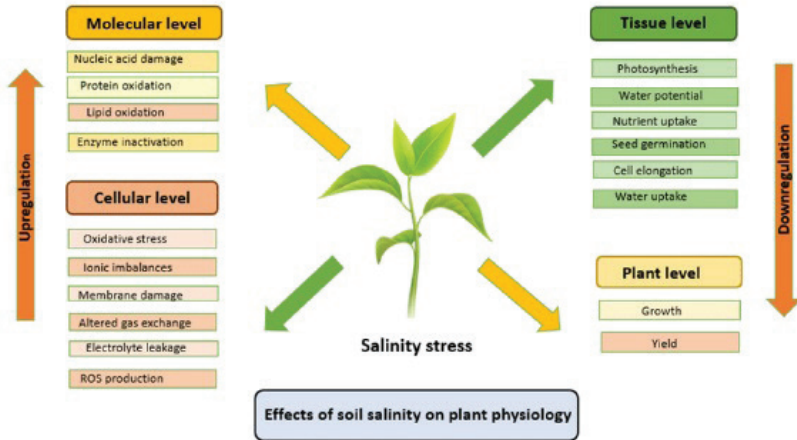

**Figure 6.** *Effects of salinity on plants (Choudhary, Wani, Naeem, Khan, & Aftab, 2022)*

## 6. Plant Protection

Silicon deficiency in plants was first observed in rice and sugar beet in the 1970s and Si was accepted as a functional plant nutrient. It was observed that Si application significantly increased diseases and pests' tolerance, and the said effect was more in sensitive genotypes (Fig. 7).

Silicon forms a mechanical barrier against insect damage by being stored in the tissues of *Monocotyledons*. Nowadays, in addition to this passive role of Si against crop diseases and pests, its physiological effects are also being studied. It is also thought that Si provides physiological durability by promoting the production of tannic and phenolic compounds in the fight against agricultural pests (M. Liang, Gatarayiha, & Adandonon, 2006).

Today, Si can be used in different ways in agricultural struggle. Nanotechnology, one of the uses of Si in agriculture, is one of the important tools in modern farming and is expected to revolutionize the field of pest management soon (Thabet et al., 2021).

Unlike conventional hydrophobic pesticides, nanocytes can be water – soluble (hydrophilic) and may increase bioactivity (Zhang et al., 2008) because they can be applied in small volumes and are rapidly uptake by cells. The use of nanocytes can slow the development of resistance of insects (Ayoub, Khairy, Rashwan, & Abdel-Hafez, 2017; Thabet et al., 2021).

Among nanomaterials, silica (SiO<sub>2</sub>) nanoparticles (NPs) have received great attention as a possible alternative to conventional insecticides. The insecticidal properties of silica NPs are thought to be due to their direct erosion of the insect cuticle (Thabet et al., 2021).

Silica NPs also cause malformations in tissues and organs by blocking the digestive system of insects (Thabet et al., 2021).

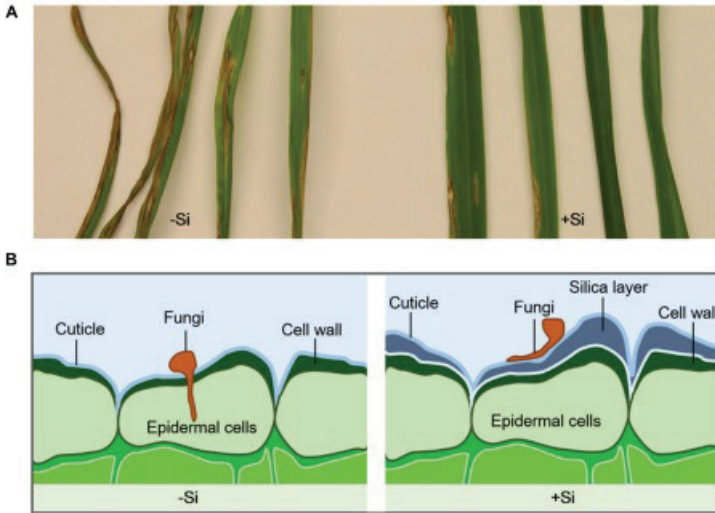

**Figure 7.** Effects of Si treatment on plant protection (M. Wang et al., 2017)

## 7. Oxidative Damage

It has been observed that Si application has a positive effect on plant growth and development under normal and stress conditions in the last 20 years. The first response of plants to abiotic stressors (salinity, drought, thermal and heavy metal etc...) is the production of singlet oxygen ( $^1\text{O}_2$ ), superoxide, hydrogen peroxide ( $\text{H}_2\text{O}_2$ ) and hydroxyl radical (OH) - which is significantly harmful for cellular membranes and organelles -. Plants produce enzymatic [superoxide dismutase (SOD), catalase (CAT) and ascorbate peroxidase (APX)] and non – enzymatic antioxidants (carotenoids, tocopherols, ascorbate, and glutathione) to overcome detrimental effects of ROS.

It has been observed that exogenous Si application prevents electronic leakage by regulating ROS formation, reduces MDA (malondialdehyde) production, and induces stress tolerance by immobilizing toxic ions such as Na under stress conditions (Kim, Khan, Waqas, & Lee, 2017).

Silicon can provide resistance to ROS toxicity induced by different abiotic stress factors, and also enhances the ROS detoxification ability of plants by modulating antioxidant defense systems and the expression of key genes associated with hormone metabolism (Mostofa et al., 2021).

## REFERENCES

- Ayoub, H., Khairy, M., Rashwan, F., & Abdel-Hafez, H. (2017). Synthesis and characterization of silica nanostructures for cotton leaf worm control. *Journal of Nanostructure in Chemistry*, 7(2), 91-100. <https://doi.org/110.1007/s40097-40017-40229-40092>.
- Baweja, P., & Kumar, G. (2020). Abiotic stress in plants: an overview. In B. Giri & M. P. Sharma (Eds.), *Plant Stress Biology: Strategies and Trends* (pp. 1-15). Singapore: Springer Singapore.
- Borrelli, G., Fragasso, M., Nigro, F., Platani, C., Papa, R., Beleggia, R., & Trono, D. (2018). Analysis of metabolic and mineral changes in response to salt stress in durum wheat (*Triticum turgidum* ssp. durum) genotypes, which differ in salinity tolerance. *Plant Physiology and Biochemistry*, 133(2018), 57-70. <https://doi.org/10.1016/j.plaphy.2018.1010.1025>.
- Choudhary, S., Wani, K., Naeem, M., Khan, M., & Aftab, T. (2022). Cellular responses, osmotic adjustments, and role of osmolytes in providing salt stress resilience in higher plants: polyamines and nitric oxide crosstalk. *Journal of Plant Growth Regulation*, 1-15. <https://doi.org/10.1007/s00344-00022-10584-00347>.
- Corrales, I., Poschenrieder, C., & Barceló, J. (1997). Influence of silicon pretreatment on aluminium toxicity in maize roots. *Plant and Soil*, 190(2), 203-209. <https://doi.org/210.1023/A:1004209828791>.
- Dresler, S., Wójcik, M., Bednarek, W., Hanaka, A., & Tukiendorf, A. (2015). The effect of silicon on maize growth under cadmium stress. *Russian Journal of Plant Physiology*, 62(1), 86-92. <https://doi.org/10.1134/S1021443715010057>.
- Gao, X., Zou, C., Wang, L., & Zhang, F. (2006). Silicon decreases transpiration rate and conductance from stomata of maize plants. *Journal of Plant Nutrition*, 29(9), 1637-1647. <https://doi.org/1610.1080/01904160600851494>.
- Gong, H., Chen, K., Chen, G., Wang, S., & Zhang, C. (2003). Effects of silicon on growth of wheat under drought. *Journal of Plant Nutrition*, 26(5), 1055-1063. <https://doi.org/1010.1081/PLN-120020075>.
- Hattori, T., Inanaga, S., Araki, H., An, P., Morita, S., Luxová, M., & Lux, A. (2005). Application of silicon enhanced drought tolerance in *Sorghum bicolor*. *Physiologia Plantarum*, 123(4), 459-466. <https://doi.org/410.1111/j.1399-3054.2005.00481.x>.
- Horuz, A., Akinoğlu, G., & Akorkmaz, A. (2017). Abiyotik ve biyotik stres şartlarında silisyumun rolü. *Yüzüncü Yıl Üniversitesi Tarım Bilimleri Dergisi*, 27(4), 657-664. <https://doi.org/610.29133/yyutbd.309632>.
- Kaya, C., Tuna, L., & Higgs, D. (2006). Effect of silicon on plant growth and mineral nutrition of maize grown under water-stress conditions. *Journal of Plant Nutrition*, 29(8), 1469-1480. <https://doi.org/1410.1080/01904160600837238>.

- Kim, Y., Khan, A., Waqas, M., & Lee, I. (2017). Silicon regulates antioxidant activities of crop plants under abiotic-induced oxidative stress: a review. *Frontiers in Plant Science*, 17(8), 1-7. <https://doi.org/10.3389/fpls.2017.00510>.
- Liang, M., Gatarayiha, M., & Adandonon, A. (2006). Silicon use for pest control in agriculture: a review. *Proceedings of the South African Sugar Technologists' Association*, 80(1), 278-286.
- Liang, Y., Wong, J., & Wei, L. (2005). Silicon-mediated enhancement of cadmium tolerance in maize (*Zea mays* L.) grown in cadmium contaminated soil. *Chemosphere*, 58(4), 475-483. <https://doi.org/10.1016/j.chemosphere.2004.1009.1034>.
- Mir, R., Bhat, B., Yousuf, H., Islam, S., Raza, A., Rizvi, M., . . . Zargar, S. (2022). Multidimensional role of silicon to activate resilient plant growth and to mitigate abiotic stress. *Frontiers in Plant Science*, 13, 1-26. <https://doi.org/10.3389/fpls.2022.819658>.
- Mostofa, M., Rahman, M., Ansary, M., Keya, S., Abdelrahman, M., Miah, M., & Phan Tran, L. (2021). Silicon in mitigation of abiotic stress-induced oxidative damage in plants. *Critical Reviews in Biotechnology*, 41(6), 918-934. <https://pubmed.ncbi.nlm.nih.gov/33784900/>.
- Sade, B., Soylu, S., & Yetim, E. (2011). Drought and oxidative stress. *African Journal of Biotechnology*, 10(54), 11102-11109. <https://www.ajol.info/index.php/ajb/article/view/96083>.
- Sah, S., Reddy, K., & Li, J. (2022). Silicon enhances plant vegetative growth and soil water retention of soybean (*Glycine max*) plants under water-limiting conditions. *Plants*, 2022(11), 1687-1703. . <https://doi.org/10.3390/plants11131687>.
- Santi, L., & Mulyanto, D. (2018). Effect of bio-silica on drought tolerance in plants. *IOP Conference Series: Earth and Environmental Science*, 183(2018), 012-014. <https://iopscience.iop.org/article/010.1088/1755-1315/1183/1081/012014/meta>.
- Saud, S., Li, X., Chen, Y., Zhang, L., Fahad, S., Hussain, S., . . . Chen, Y. (2014). Silicon application increases drought tolerance of Kentucky bluegrass by improving plant water relations and morphophysiological functions. *The Scientific World Journal*, 2014(1), 1-10. <https://doi.org/10.1155/2014/368694>.
- Shi, Y., Zhang, Y., Yao, H., Wu, J., Sun, H., & Gong, H. (2014). Silicon improves seed germination and alleviates oxidative stress of bud seedlings in tomato under water deficit stress. *Plant Physiology and Biochemistry*, 78(2014), 27-36. <https://doi.org/10.1016/j.plaphy.2014.1002.1009>.
- Sun, Y., Xu, J., Miao, X., Lin, X., Liu, W., & Ren, H. (2021). Effects of exogenous silicon on maize seed germination and seedling growth. *Scientific Reports*, 11(1), 1-13. <https://doi.org/10.1038/s41598-41020-79723-y>.
- Suriyaprabha, R., Karunakaran, G., Yuvakkumar, R., Prabu, P., Rajendran, V., & Kannan, N. (2012). Growth and physiological responses of maize (*Zea*

- mays* L.) to porous silica nanoparticles in soil. *Journal of Nanoparticle Research*, 14(12), 1-14. <https://doi.org/10.1007/s11051-11012-11294-11056>.
- Thabet, A., Boraiei, H., Galal, O., El-Samahy, M., Mousa, K., Zhang, Y., . . . Nozaki, T. (2021). Silica nanoparticles as pesticide against insects of different feeding types and their non-target attraction of predators. *Scientific Reports*, 11(1), 1-13. <https://doi.org/10.1038/s41598-41021-93518-41599>.
- Thorne, S., Hartley, S., & Maathuis, F. (2020). Is silicon a panacea for alleviating drought and salt stress in crops? *Frontiers in Plant Science*, 11(1221), 1-16. <https://doi.org/10.3389/fpls.2020.01221>.
- Vaculík, M., Lux, A., Luxová, M., Tanimoto, E., & Lichtscheidl, I. (2009). Silicon mitigates cadmium inhibitory effects in young maize plants. *Environmental and Experimental Botany*, 67(1), 52-58. <https://doi.org/10.1016/j.envexpbot.2009.1006.1012>.
- Wang, M., Gao, L., Dong, S., Sun, Y., Shen, Q., & Guo, S. (2017). Role of silicon on plant–pathogen interactions. *Frontiers in Plant Science*, 8, 1-14. <https://doi.org/10.3389/fpls.2017.00701>.
- Wang, M., Wang, R., Mur, L., Ruan, J., Shen, Q., & Guo, S. (2021). Functions of silicon in plant drought stress responses. *Horticulture Research*, 8(254), 1-13. <https://doi.org/10.1038/s41438-41021-00681-41431>.
- Wang, S., Liu, P., Chen, D., Yin, L., Li, H., & Deng, X. (2015). Silicon enhanced salt tolerance by improving the root water uptake and decreasing the ion toxicity in cucumber. *Frontiers in Plant Science*, 2015(6), 1-10. <https://doi.org/10.3389/fpls.2015.00759>.
- Xie, Z., Song, F., Xu, H., Shao, H., & Song, R. (2014). Effects of silicon on photosynthetic characteristics of maize (*Zea mays* L.) on alluvial soil. *The Scientific World Journal*, 2014, 1-6. <https://doi.org/10.1155/2014/718716>.
- Zhang, H., Zhu, J., Gong, Z., & Zhu, J. (2022). Abiotic stress responses in plants. *Nature Reviews Genetics*, 23(2), 104-119. <https://doi.org/10.1038/s41576-41021-00413-41570>.





## **CHAPTER 12**

### **A REVIEW OF THE WORLD'S WHEY CHEESES**

*Seval Sevgi KIRDAR<sup>1</sup>*

---

<sup>1</sup> Prof.Dr. Burdur Mehmet Akif Ersoy University Burdur Food, Agriculture and Livestock Vocational School Food Processing Department Dairy and Products Technology Programme ID: <https://orcid.org/0000-0003-4836-7496>

## 1. INTRODUCTION

Since the inception of the manufacture of cheese, or for more than 8,000 years, whey has been a well-known by-product. Whey was recommended as a medicine for the treatment of tuberculosis, skin conditions, digestive issues, and jaundices a medicine by Hypocrites in 460 BC for the treatment of tuberculosis, skin conditions, digestive issues, and jaundice. Whey was used to cure diarrhea, dysentery, and various poisonings in the 18th century in Switzerland, Austria, and Germany. At the time, whey was widely believed to have invigorating and diuretic qualities (Tratnik, 2003). Later, it evolved into an undesirable by-product in the cheese-making process (Blažić et al., 2017).

In the process of creating cheese, milk casein is precipitated and removed, leaving behind cheese whey (CW), a greenish-yellowish liquid (Siso, 1996). Riboflavin (vitamin B<sub>2</sub>) is what gives cheese whey its yellowish hue (De Wit, 2001). The majority (90%) of the organic load, or about 39–60 kg/m<sup>3</sup>, of the milk lactose is still present in the cheese whey (Ghaly and Kamal, 2004; Kisaalita et al., 1990). With values between 0.99 and 10.58 kg/m<sup>3</sup> and 1.4 and 8.0 kg/m<sup>3</sup>, respectively, fat and protein concentrations are also partially to blame for organic contamination. BOD and COD had levels between 27 and 60 kg/m<sup>3</sup> and 50 and 102 kg/m<sup>3</sup>, respectively. Commonly, the BOD<sub>5</sub>/COD ratio exceeds 0.5. Therefore, this substrate is appropriate for biological processes to process. Mineral salts (0.46–10%), particularly NaCl and KCl (> 50%), and calcium salts (mostly phosphates) are responsible for the inorganic contamination of cheese whey (Dragone et al., 2009; Prazeres et al., 2012). NaCl addition during cheese making results in inorganic contamination. Running biological digesters can be problematic if there is a high sodium level (Backus et al., 1988).

Lactose, soluble proteins, minerals, lactic acid, and lipids from the original milk are all present in cheese whey, along with 93–94% of its weight in water. In addition, the composition of CW contains sizeable amounts of additional substances such as citric acid, non-protein nitrogen molecules (urea and uric acid), vitamins (B group), etc. (Garca Bilbao, 1981; Kosikowski and Wierzbicki, 1973; Panesar et al., 2007). The cheese whey composition contains immunoglobulins, lactoglobulins, lactoferrin, and serum albumin. Interest in cheese whey valorization has increased due to the protein concentrates' health benefits and nutritional qualities (Prazeres et al., 2012).

Whey comes in two varieties: acid whey and sweet whey. Acid whey is produced from cottage cheeses (pH 3.6–5.1), whereas sweet whey is a by-product of the manufacturing of ripened cheese (pH 5.8–6.6). (Anand et al., 2013). Sweet bovine whey, which is produced during the preparation of some

casein products or most varieties of cheese, has a pH of about 6-7, 6–10 g L<sup>-1</sup> of protein, 5–6 g L<sup>-1</sup> of fat, 46–52 g L<sup>-1</sup> of lactose, and 2.5–4 g L<sup>-1</sup> of minerals (Ryan and Walsh, 2016; Pintado et al., 2001). Rennet is added to milk as the first stage in the production of cheese (and sweet whey). The casein in the milk is curdled by the rennet, resulting in the creation of curd. The leftover liquid is then filtered, leaving the curd behind (CW). At pH 6.0–6.5, casein coagulates when rennet is added (Argenta and Scheer 2019).

According to Argenta and Scheer (2019; Siso, 1996), acid whey has a pH range of 4.5 to 5.8, 6 to 8 g of protein, 5 to 6 g of fat, 44 to 46 g of lactose, and 4.3 to 7.2 g of minerals per liter (Gua and Wang, 2019). This whey is produced by the action of lactobacilli, the addition of lactic acid, or the usage of mineral acids, which are utilized to coagulate the casein for the production of the majority of industrial casein types. It also happens when acid-curdled cheeses are made, such as cottage cheese. While the mineral concentration of acid whey typically exceeds that of sweet whey, the lactose amount is typically lower (Siso 1996; Pintado et al. 2019).

## **2. USE OF WHEY AND WHEY PREPARATIONS IN THE FOOD INDUSTRY**

The following whey processing products are utilized in the meat industry: sweet whey powder, whey protein concentrates (WPCs) (34–80% protein content), whey protein isolate (WPI) (> 90% protein), whey with reduced lactose concentration, demineralized whey, and lactose (Keaton, 1999; Prabhu, 2006). They are utilized mostly in the preparation of ground meats, such as frankfurters, sausages, mortadellas, luncheon meat, and surimi (De Wit, 2001). In the baking, candy, and pastry industries, whey is often used to make breads, cakes, cookies, biscuits, crackers, muffins, and frosting (Królczyk et al., 2016).

Whey products like demineralized whey powders, low-lactose whey powders, WPCs, isolates, and lactose have been used in chocolates and chocolate chips, candies, jellies, and chewing gums (Królczyk et al., 2016).

Whey preparations such as sweet whey powder, powdered whey with less lactose, WPCs, and WPI can be used to make processed cheese and processed cheese substitutes (Young, 1999). Whey cheeses can be made from the liquid, sweet whey that remains after making cheese from cow and sheep milk (Philippopoulos & Papadakis, 2001; Salvatore et al., 2014; Wendorff, 2008).

Additionally, newborn formulas and whey drinks are produced from whey in the food company. As a source of high-quality protein and active peptides, whey preparations are commonly utilized by manufacturers of baby foods (Królczyk et al., 2016). Another protective application for whey

proteins is as a food covering (Galus & Kadziska, 2016). According to a number of writers, coatings derived from whey preparations have excellent mechanical qualities and a strong barrier against lipids, aromatics, and, most importantly, oxygen. Whey protein can be used to successfully cover fruits and vegetables. Alcoholic beverages using whey appear to be an intriguing application of whey. These items include whey beer, wine, and “champagne” made from whey. They are distinguished by their modest alcohol content (1.5%) (Kirdar, 2001; Królczyk et al 2016).

## 2. WHEY CHEESES IN THE WORLD

Around 5,000 B.C., Kanana in Mesopotamia discovered that storing arm milk in a bag fashioned from the fresh stomach skin of sheep (or goats) created curds and, consequently, whey (Malcata, 1991). Later, nomad shepherds started boiling whey in copper kettles to make solid meals that were both healthy and filling (Kosikowski, 1982).

Whey proteins are denaturalized to create whey cheeses, which are produced all over the world, typically on a local scale and in accordance with traditional methods (which also have associated residual fat). Depending on the nation and location from where they come, these cheeses have different names (Table 1). (Figure 1).

Whey is heated and partially condensed by evaporation during the traditional process of making whey cheeses, which takes place in open cheese kettles. For small dairy enterprises, the cost-effective alternative to labor-intensive and expensive membrane- or chromatography-based protein separation is the heat-induced processing of whey (Pintado et al., 2001). One of the industrial whey cheese making techniques used today is vacuum evaporation. Before making whey cheese, whey can be pre-concentrated for the creation of whey cheeses. Other raw materials obtained from milk may be added as long as the whey proteins continue to make up the majority of the final product. Cheese made from whey might be fresh or matured. Whey cheeses have a yellowish or brown appearance and a sweet, cooked, or caramelized flavor due to the high lactose concentration of whey. Whey cheeses can be used in a variety of dishes, including desserts and appetizers. Ricotta whey cheese is mostly used in the United States to make desserts and pasta dishes like lasagna and manicotti. The Myzithra whey cheese is popular in regional cheese pies in Greece, whereas the Requeijo whey cheese is typically used in desserts such as puddings and cakes in Portugal (Pintado, et al., 2001).

*Table.1. Whey cheeses in the World*

<b>Country</b>	<b>Namw of whey cheese</b>	<b>Reference</b>
Argentina	Ricotta	Kandarikis, 1986
Brazil	Requeijao do Norte, Ricotta fresca	Jassen-Escudero and Rodriguez-Amaya, 1981
Bulgarian	Otvora	Kandarikis, 1986
Corcica	Broccia	Tonguç ve Karagözlü 2012
Cyprus	Anari	Williams and Syson, 1984; Kandarikis, 1986
Czechoslovakia	Urda, Zincica	Kandarikis, 1986
Egypt	Karish	Kamber 2005
Ex-Yugoslavia	Scuta, Puin	Stefanovic & Djordjevic, 1969, Kosikowski, 1982
Ex-USSR	Nadigi, Kaukaz	Kandarikis, 1986
France	Serac, Brousse, Broccio, Greuil	Kandarikis, 1986
Germany	Zieger, Schottenzieger, Schabzieger	Kandarikis, 1986
Greece	Manouri, Myzithra, Anthotyros	Kandarikis, 1986
Crotia	Bračka skuta	Roka et al.2018
Iraq	Lour	Kandarikis, 1986
İsrael	Urda	Kandarikis, 1986
İtaly	Ricotta (gentile, pecorina or romana)	Kandarikis, 1986
Lebanon	Kariche	Kandarikis, 1986
Macedonia	Urda	Kandarikis, 1986
Malta	Cacio-ricotta	Kandarikis, 1986
Northern Africa	Nicotta	Kandarikis, 1986
Norway	Mysost, Primost, Gjestost, Grubransdalsost	Jelen and Buchheim, 1976
Peru	Regueson	Tonguç ve Karagözlü 2012
Poland	Żentyca	Kawęcka & Pasternak, 2020
Portugal	Requeijão	Kandarikis, 1986
Romania	Ziger, Urda	Kandarikis, 1986
Spain	Requesón	Kandarikis, 1986
Switzerland	Schottenziegr, Hudelziger, Mascarpone	Kandarikis, 1986
Tunisia	Klila	Kandarikis, 1986
Turkey	Lor	Kırdar, 2009
USA	Ricotone, Ricotta	Kandarikis, 1986, Kosikowski, 1982



Figure 1. Whey cheeses in the World

## 2.1. ŻENTYCA (POLAND)

Żentyca is a seasonal food that is only produced from May to September while mountain sheep are grazing in the Carpathian Mountains. Visitors to the Polish mountains find it to be incredibly popular. The production process has not altered in centuries, despite the fact that its nutritional and health benefits have long been recognized. It is consumed warm, right after “cooking,” or after a few days of fermentation, giving it the characteristic tart-sour flavor. Tourists receive it in wooden cups from shepherd’s cottages. The quantity of whey and coagulated whey proteins, as well as the density and makeup of Żentyca, are dependent on the manufacturer and vary between different shepherd’s huts (Drod 2007).

Żentyca is created by boiling the leftover whey from making mountain cheeses. A delicate skin emerges on the surface of the heated liquid in the cheese vat when the whey protein coagulates at 90°C due to its lighter weight. Fresh Żentyca is placed into a wooden barrel after every milk processing session, unlike Italian Ricotta, which is formed by filtering the leftover whey proteins on a strainer. Here, thanks to its own natural microflora, it goes through a fermentation (acidification) process (Scatassa et al. 2018).

## 2.2. RICOTTA (ITALY)

Ricotta cheese is an Italian cheese made with whey mostly derived from cheeses produced from cow, goat, sheep and buffalo milk. Ricotta cheese, like Mozzarella cheese, is a type of cheese that is consumed without ripening. It is reported that there are about 30 different Ricotta varieties in the southern regions of Italy, depending on the production technique, raw materials used and storage conditions. Greeks and Romans already made ricotta; in fact Columella, in his *De Re Rustica*, describes the various phases of its production. In the southern regions of Italy, Ricotta cheese is mostly produced from the whey leftover from cheeses made from other milks, with the exception of cow’s milk. For this reason, it is

mostly seasonal production and production is carried out by adhering to traditional production in the region (Aydın & Guneşer, 2021).

Ricotta has gained enormous popularity all over the world because to its many applications, which include direct eating, integration in pasta filling, and confectionary items (Ortiz Araque et al., 2018). It is generally very soft, spreadable, extremely delicate, easily broken and crumbly. It is widely produced in Italy and Portugal, other Southern European and Latin American countries and the USA. The use of ricotta cheese in Italian pastas such as lasagna and ravioli, its involvement in cheesecake making has led to worldwide recognition of Ricotta (Tonguç & Karagözlü 2012).

Although only whey is used in traditional Ricotta production, today, milk or a mixture of both is used as well as whey. Cheese produced only from whey is sometimes referred to as “Ricotone”. The type obtained from skimmed milk is called “Impasta”. There are many types of ricotta cheese. For example; Cheese obtained from the whey leftover from sheep’s milk cheese making is called “Ricotta di pecora” or “Ricotta pecorina”. Ricotta cheese, which is made from the whey of cheeses made from cow’s milk, is usually called “Ricotta vaccina”. However, this cheese is also called “Ricotta Piemontese” because it is mostly produced in the Piedmont region in Italy. Ricotta cheese is consumed both fresh and used in the preparation of some Italian dishes. It is also used in the preparation of salad dressings and various desserts (Tonguç & Karagözlü 2012).

Ricotta, which literally translates to “re-cooked,” refers to a creamy curd that is created by reheating the whey, a byproduct of producing cheese (Mahran et al., 1999). Ricotta curds have a taste that is slightly sweet, very fresh, and white and creamy. Depending on the type of milk used in the procedure, the form and weight may vary, but the cheese often has a conical shape obtained by using a fuscella, a traditional container in which the cheese is placed after skimming in order to drain. It can be eaten alone or with other cheeses or cold cuts, but because of its delicate aroma, it also works well as an ingredient in many dishes. A fresh, unripened, grainy cheese that is white, soft, and moist is what ricotta is typically sold as. When it is made from fresh, sweet whey, it is generally bland or, at most, semi-sweet. Ricotta was initially produced in Lazio and Sicily, primarily Sardinia, where there was an abundance of ovine milk. However, these whey cheeses were eventually sold all throughout Italy and even exported to other nations, particularly the USA. (Kosikowski, 1982a).

### **2.3. RICOTTA ROMANA (PDO)**

Ricotta Romana is produced using raw milk sheep from Sarda, Comisana, Sopravvissana, Massese and their interbreed in Lazio region area. The whey is heated to 50-60 ° C; during this process a maximum of 15%

raw milk sheep is added. The whey, with the possible addition of sodium chloride (max 4 g/l), is heated to 85-90° C and maintained in slight agitation. The heating promotes the precipitation and coagulation of serum proteins and their emerging like small flakes. Subsequently ricotta is put in typical packaging (fucella) for about 24 hours to facilitate the purging of whey. The product is drained in rooms at 4-6°C. The ricotta has a delicate texture, a colour more pronounced than vaccine one and a sweet flavour. Ricotta Romana has been recognized as a PDO (Protected Designation of Origin) in the European Union. Ricotta Romana is white, lumpy, and has a distinctively sweet and milky flavor. The cheese can be consumed on its own or used as a component in a variety of cuisines. It is recommended that you serve it with rye bread or dill bread (Filipetti et al., 2017).

#### **2.4. RICOTTA DÌ BUFALA CAMPANA**

*Ricotta di Bufala Campana* is a product obtained through the processing of the ‘first whey’ (sweet) obtained in the cheese-making process which uses milk from the *Mediterranea Italiana* buffalo breed. The provinces of Benevento, Caserta, Naples, and Salerno in Campania; Frosinone, Latina, and Rome in the Lazio region; Foggia in the Apulia region; and Isernia in the Molise region comprise the production area (Tripaldi et al., 2020).

Since the entrance of buffalo in Southern Italy in the sixteenth century, Ricotta di Bufala Campana and Mozzarella di Bufala Campana manufacture have been inextricably intertwined. Ricotta di Bufala Campana differs from other ricotta cheeses due to its creamy consistency, softness, color, and pleasant milky scents, which are a result of buffalo whey’s higher fat content and absence of lipase, an enzyme that can alter the sensory properties of fat (Figure 1).

The ricotta is smooth and creamy, porcelain white, rindless, and has a consistency that is gritty but not sandy. The perfume is reminiscent of milk and cream, and the flavor is distinctive, fresh, and just a little bit sweet. It can be consumed on its own or as an ingredient in a variety of cuisines that are filled. The ingredient is typically used to make regional sweet and savory Neapolitan recipes. One of the most well-known recipes is for Pastiera Napoletana, a traditional Easter cake (Tripaldi et al., 2020).

#### **2.5. REQUEIJÃO (PORTUGAL) AND REQUESÓN (SPAIN)**

Dairy industries produce Requeijo (in Portugal) and Requesón (in Spain) mostly from bovine whey milk; but, traditional Iberian whey cheeses are still produced on farms by adding a small percentage of caprine milk to ovine whey. Only 2% (v/v) of the total whey produced in Portugal is utilized to produce Requeijo, which accounts for 630 tons of the end

product. This whey cheese is small (150 g), white, and semi-sweet whey cheese is flavorful. The conventional method of producing Requeijo involves heating the beginning material, i.e., bovine whey or ovine whey, or mixes thereof with ovine or caprine milk, between 90 and 100 °C for around 15 minutes while stirring continuously. When coagulation occurs at temperatures near 85 °C, a little amount of cold water is occasionally introduced to enhance the development of coagulum. The curd spontaneously rises to the surface and is then scooped into wooden or plastic molds for a few hours of draining and cooling (Kandarikis, 1986).

## **2.6. MYSOST (NORWAY)**

In Norway, Mysost, a distinctive bovine whey cheese, is now being produced. Mysost has not been widely adopted by consumers outside of Scandinavia, however this product can occasionally be found at specialty cheese shops in Germany, the United States, and Canada. Mysost is often made from fresh, sweet bovine or caprine whey and is either a hard cheese or a spread-type cheese. Brunost finally took the place of the generic name for this kind of bovine whey cheese as makers began to add cream around the turn of the century. Cheese is known as Gjestot when plain caprine whey milk is used. The cheese is gritty and dark brown in color. That whey cheese has a 40% lactose content. For travelers in Northern Norway, W/V offers a reliable supply of energy. Primost, which has a light tan color, a smooth, creamy body, and a texture where lactose crystals are barely perceptible, is a substance that is frequently used to enhance the sensory qualities of caprine whey milk. It tastes like cream that has been very slightly sweetened. At 5°C, Mysost cheeses maintain their qualities for up to six months (or even longer) (Kosikowski, 1982).

## **2.7. GRUBRANSDALSTOST (NORWAY)**

The most well-known cheese made from condensed whey in Norway is called Grubransdalsost. The fresh, sweet whey produced by the coagulation of full-fat caprine milk and bovine milk (at a ratio of 88:12) or by the production of Cheddar, Swiss, or Mozzarella cheese is typically supplemented with enough fresh cream to give it 3% (w/v) fat. Pumping the whey and cream combination into a stainless steel, two-stage (or double effect) evaporating pan concentrates the creamed whey to roughly 50% (w/v) total solids. The heavy, viscous fluid is then immediately placed into a circular vacuum kettle and heated under vigorous, prolonged agitation until the concentration approaches 80% (w/v) total solids. The concentrated whey is then heated to around 95 °C and stirred until the appropriate brown color and usual flavor strength are achieved. The vacuum is then released, the cover is opened (Jelen and Buchheim, 1976). By turning the kettle to the right angle and dipping it into a circular wooden tub with a powerful

rotating sweep metal agitator, this plastic material is removed. To achieve a fine-grained, buttery texture, the mass is handled for about 20 minutes at room temperature. At this point, the production of big lactose crystals is prevented by uniform, constant agitation. The plastic mass is transported to a butter printer equipped with an Archimedes screw and wire-cutting bars while it is still warm. There, the plastic mass is extruded and cut into approximately 0.25, 0.50, 2.5, or 4.5 kilogram blocks, which are then lightly waxed, packaged, and properly traded (Kosikowski, 1982).

### **2.8. BROWN CHEESE (BRUNOST)(NORWAY)**

Brunost is a brown processed cheese from Norway and Scandinavia that is created from the whey of cow and goat milk. Since it's manufactured from a byproduct, it's technically not even a cheese. To get caramelized sugar, the whey is cooked down. The amount of time the cheese is boiled for determines how dark and rich its color will be (Figure 1). The mixture is put into bags and let to cool so the sugars can crystallize. When it has chilled, it is packaged into a block and is ready for consumption. The texture of Brunost is dense, and the flavors are sweet and caramel-like. It is advised to serve it with strawberry jam on rye toast (Kosikowski, 1982).

### **2.9. MANOURI (WESTERN MACEDONIA, IN NORTHERN GREECE)**

Manouri, like myzithra, is a whey cheese, but it has a softer, creamier, less salty, and more refined texture and flavor. Manouri has historically been produced in the region of Western Macedonia in northern Greece from the whey leftover from making batzos, a semihard cheese made from caprine milk or a combination of caprine and ovine milks. Although manouri is technically a whey cheese, it is now being created from the whey of cheeses that use only ovine milk. Manouri production shares a lot of the same technology as myzithra production, however the finished product has a lower moisture content (50-60%) (Lioliou et al. 2001).

### **2.10.URDA (BALKANS)**

Fresh whey cheese known as Urda is made all over the Balkans. Cow, sheep, or goat milk whey is used to make the cheese. It has a flaky, gritty, and silky texture (Figure.1). The flavor is light, sweet, and milky, with fresh scents. Urda is frequently shaped into semi-spheres. The cheese is used as a pastry filling and in the making of sweets. Urda is popular in Romania, the Pirot region of Serbia, Macedonia, Montenegro and Hungary, and Epirus, Greece, among other nations that claim ownership of it (during summer).

The manufacture of "Urda" cheese has a long history in Montenegro's hilly regions. It is still referred to as "skuta," "furda," "hurda," "bjelava,"

“cvarog,” and “provara” in the former Yugoslavia. Due to the fact that milk whey is heated during the production of this product, the name “provara” best describes it. It is known as the “izvara” in Bulgaria and the “ricotta” in Italy.

Urda is traditionally made in the Carpathians using sheep whey. The whey is warmed and its proteins are separated to create urda. Proteins, primarily albumin and globulin, which float on the surface and trap the fat droplets left over from the cheese-making process, become denatured at temperatures between 85 and 90 °C (Ucuncu, 2004).

### **2.11. ZIGER (SWITZERLAND)**

Ziger has a long history of traditional production in Switzerland, and the main goal of its creation was to conserve milk’s nutritious components before rennet-induced cheese production surpassed them (Hösli & Schläpfer, 2012). Fresh whey from rennet-induced cheese manufacture is necessary for the traditional production of Ziger. The whey can be heated to between 88 and 92 and 91 to 93 degrees Celsius (Ernst & Gonzalez, 2015; Zufferey, 2012). The addition of acid—mostly acetic acid—causes the whey proteins to precipitate (Hösli & Schläpfer, 2012). NaCl is utilized to help hasten the aggregation process further. Whey cheeses often consist of fresh cheeses with a high moisture content, a pH level that is close to neutral, and a low salt content, all of which create a relatively favorable environment for bacterial growth (Pintado et al., 2001).

Due to the limited shelf life of Ziger whey cheese, rennet-induced cheese production more or less replaced Ziger production in the 16th and 17th centuries (Hösli & Schläpfer, 2012). Only whey or perhaps a combination of whey and buttermilk may then be used to make Ziger. In Switzerland, only the Ziger, sometimes known as the Schabziger, made in the Glarus canton, has achieved wide-spread appeal.

### **2.12. PAŠKA SKUTA (CROATIA)**

Traditional Croatian ricotta-style cheese known as Paška skuta is made on the Pag island. After the creation of the renowned and award-winning Paška sir, leftover whey is used to make the skuta. The curd is separated and then drained, typically over night, producing a soft, fresh cheese with a distinctively mild and delicate flavor made from the milk of the local Pag sheep (Paška ovca) (Figure.1). This fresh skuta is low in fat and rich in protein, calcium, zinc, and the beneficial omega-3 fatty acids. The cheese can be used in a variety of dishes and is best served with fresh fruit and cheesecakes or flavored with orange liqueur. On the island of Pag, people frequently started their days with a cup of black coffee with pieces of paka skuta poured inside of it, while the powerful bura wind swept over the landscape. Paška skuta is particularly beneficial for liver regeneration (Antunac et al., 2011).

### 2.13. BRAČKA SKUTA (CROATIA)

The Bračka skuta whey cheese was obtained by heating whey until proteins coagulated and floated to the surface. The procedure was completed soon before the whey reached boiling (95–97 °C) and formed a distinct layer of whey proteins. A perforated ladle was used to transfer the coagulum into cylindrical moulds, where it was left to drain for 2 hours at room temperature before being put into refrigerators to cool to 4 °C within the following 24 hours. In Figure 1. About 38.03 g of total solids, 24.93 g of fat, 9.70 g of proteins, and 3.70 g of lactose were present in every 100 g of braki albumin cheese. The average value of energy was 1150 kJ. (Roka et al 2018).

### 2.14. ANARI (CYRUPS)

*Anari* is a white Cypriot cheese made from goat's or sheep's milk. Its flavors are best characterized as light and salty, while its texture is creamy, flaky, and brittle. There are two types of cheese that can be produced: fresh and dry. Fresh anari is frequently eaten for breakfast with honey or fruit jams because of its soft texture and moderately salty, slightly sweet flavor (Figure.1). Salted dry anari is first dried in the oven or the sun. Due to its tough texture, it is frequently shredded and used as a garnish on many pasta dishes. The dry form, on the other hand, can also be crushed and added to various salads (Papademas et al, 2007).

### 2.15. MYZITHRA (GREECE)

Traditional Greek cheese known as myzithra is created from the whey of cheeses made from cow, goat, or sheep's milk. There are three main types: old, sour, and fresh. The fresh one usually takes the form of eggs or balls and has a soft, unsalted feel (Figure 1). Although the flavor is relatively moderate, the scent is strong. The aged type of myzithra has a hard texture and is quite salty. It is made using sheep or goat milk, yeast, and salt. The aged version tastes finest when grated over spaghetti, soups, and casseroles, whilst the first two varieties are frequently used in baked pastries and sweets (Zerfiridis, et al., 1985).

### 2.16. MANOURI (Western Macedonia and in Thessalia)

Manouri is a fresh whey cheese that is only produced in Thessalia, Central Macedonia, and Western Macedonia. It is silky smooth and flavorful. It is a specific variety of unseasoned myzithra cheese that dates back to the Byzantine era. One of the best varieties of manouri is that prepared in the Macedonian region of Mplatsi, which is created by combining the whey from the production of hard cheeses, mainly feta, with milk and cream and either goat or sheep milk (Figure 1). It is sturdy enough to be cut even though it is rather soft. Although this cheese is less salty and more

creamy than feta, it has a flavor that is similar. It is said to smell creamy and a little bit sour. This cylindrical cheese is often referred to as Manoypi. It is typically consumed with honey or in cheesecakes, or used to make pastries like spanikopita. (Lioliou et al., 2001).

### **2.17.XYNOMYZITHRA KRITIS**

This soft table cheese is produced by combining whey from the production of Graviera or Kefalotyri Kritis cheeses with sheep or goat milk, or a combination of both. Its name is composed of the terms mizithra and xyno, which together mean “acidic whey cheese.” Since the 17th century, it has been manufactured on the picturesque island of Crete in the Chania, Rethymno, Heraklion, and Lasithi prefectures. Today, Xynomyzithra Kritis is one of Crete’s most popular cheeses. This beautiful, rindless, white cheese has a distinct sweet and sour flavor, and its texture can range from creamy to grainy. As it gets milder and softer when cooked, Xynomyzithra Kritis can be utilized in a number of dishes (Medina & Nunez 2017).

### **2.18. BROCCIU CORSE (CORSICA ISLAND)**

Brocciu is a fresh or matured cheese manufactured on the island of Corsica from goat’s or sheep’s milk and whey (Figure 1). It can be used as a lactose-free substitute for Italian Ricotta cheese. It has a smooth, creamy, and crumbly consistency, and its fat content ranges between 40 and 50%. If consumed young and fresh, drain it using cheesecloth or a sieve to eliminate extra liquid. When offered as aged cheese, the cheese is aged for a few weeks to a month. It has a sweet, milky flavor and is ideal for use in omelettes, baked goods such as pastries, and soups. On its own, it pairs best with red wine or white wines from Corsica (Guerrini et al., 2001).

## **3. TRADITIONAL WHEY CHEESE IN TURKEY**

Anatolia was the birthplace of numerous civilizations for thousands of years, and because to its favorable terrain for raising livestock, it is well-endowed in terms of the range of cheeses it produces. Anatolia is the home of more than 130 different kinds of cheese, despite the impression that Turkey does not have a sophisticated cheese culture.

According to data from the Turkish Statistical Institute (TUIK), Turkey manufactured 756,646 tons of cheese in 2020. The remaining 27,108 tons (3.6%) are made up of other cheeses (produced from sheep, goat, buffalo, and/or mixed milk), which make up the remaining 729,539 tons (96.4%) of the total. It may be computed that around 24% of the total volume of milk (22,960,379 tons) produced in our nation is processed into cheese using an average cheese yield of 13% (including soft and hard cheeses). According to data from 2020, roughly 16.6% of the cheeses produced are of the soft type (125.556 tons), 30.1% are of the medium soft type (228.026

tons), 21% are of the hard type (158.819 tons), 30.7% are of the medium hard type (232.419 tons), 1.3% are of the extra-hard type (9.573 tons), and 0.3% are cheeses made from curd (1,252 tons) (TEPGE, 2020, akmakç and Sal The overall amount of cheese produced in Turkey in 2019 declined by 6.5% compared to the previous year to 707 thousand tons, while the total amount of cheese supplied climbed by 6.6% to 714 thousand tons, and cheese exports reached 50,000 tons, as computed as follows: Turkey is the fourth-largest producer of cheese worldwide (TEPGE, 2020).

Local whey cheeses go by a variety of names and are made utilizing diverse production methods and milk varieties depending on the region (Table 2.) (Figure.2)

Table 2 .Whey cheeses produced in Turkey (Kırdar 2021)

Whey Cheese Name	Province	Raw materyal
Dolaz cheese	Isparta	Whey and goat milk, buttermilk, cow's milk,yogurt, tulum
Armola cheese	İzmir	Yogurt, Lor cheese,White cheese, tulum
Kırlı hanım cheese	Ayvalık	Whey and goat milk
Kopanisti cheese	İzmir- Çeşme- Foça- Karaburun	Whey and goat milk
Sepet loru	Ayvalık- Foça	Lor cheese, sepet
Tire Çamur cheese	İzmir-Tire	Lor cheese, ripened tin Tulum cheese
Otlı Lor cheese	Van	Whey, herby mixed
Şor Loru cheese	Kars	Whey
Sırvatka Loru cheese	Bursa-Balıkesir-Manyas	Mihaliç whey, boiling water, wood barrel
Nor cheese	Kıbrıs, Mersin, Silifke	Whey
Lorlu kaşar kırığı	Bayburt	Bad molded Kashar cheese, Lor cheese, wooden barrel or Plastic Can
Ekşi(siyah) cheese	Çankırı	Whey



LOR CHEESE



KİRLİ HANIM CHEESE



TİRE ÇAMUR CHEESE



DOLAZ CHEESE



ARMOLA CHEESE



BASKET LOR CHEESE



KOPANİSTİ CHEESE



OTLU(HERBY) LOR CHEESE



BROKEN KASHAR WITH LOR CHEESE



YUMME CHEESE

Figure 2. Traditional Whey Cheeses in the Turkey

### 3.1. LOR CHEESE

Turkish's "lor" is derived from the Persian word "lür." Whey, a watery byproduct of cheesemaking, is obtained from cheese manufacture in Turkey each year and has traditionally been utilized to make lor cheese. As a result, in Turkey's western and rural areas, lor is one of the most consumed and well-liked cheeses (Kırdar & Gün, 1999; Temiz, et al. 2009).

The name of the cheese varies depending on where you are. Depending on the milk source, kind of manufacturing procedure, and locality, there are various types of lor cheese available in Turkey. Anatolia is home to several lor cheese factories, including Sepet Lor in Ayvalik, Sor Lor and Kurtlu Lor in Kars, Otlu Lor in Van, Dolaz in Isparta, Sirvatka Lor in Bursa and Balikesir, Eksi in Cankiri, Tire Camur in Izmir, Nor in Mersin and Minzi/Minci, and Kerti Lor in Kerti (Table 1; Figure 1) (Kamber 2005)

Every region of Turkey produces the cheese variant known as "Lor Cheese." Although this soft cheese is typically eaten unripened, in some regions it is allowed to mature. Typically, it is identified by the name of the object it is housed in (tulum: an animal hide, küp: an earthenware jar). It is suggested as a diet cheese due to its low fat level. Lor cheese is frequently used in desserts and pastries like "börek" and "cörek," and it is also consumed at the breakfast table when combined with spices and olive oil. In the past, the cheese was typically made in villages to use the leftover whey from the manufacturing of butter and cheese for home needs, but recently, factory production of the cheese has started (Demirci et al., 1991).

Lor cheese often has a soft consistency and granular texture, and it is cream, pale cream, or off-white in color. It comes in a range of sizes, has a minimal fat content, and takes the form of its container. Turkey is home to an abundance of delectable Lor Cheeses that are regionally distinct, manufactured in diverse ways, and preserved in various types of containers. The procedure of creating Lor Cheese will only be covered in broad strokes here. The leftover whey from cheese manufacture or buttermilk from yoghurt making are placed in shallow cauldrons and heated to a boil. Taking care that it does not boil too quickly, the liquid is regularly and gently stirred. (Lemon or citric acid may be added on occasion) Gradually, coagulation takes place in the cauldron, after which the coagulate is collected using ladles with slots and deposited in fine cotton bags. The opening of the fabric bag is tied, and it is hung from a height to drain. Depending on its quantity, the uncooked cheese is next placed in a hemp cloth or left in the straining cloth and pressed. After properly draining the whey (about four hours), it is lightly seasoned with fine salt. When it is ready for eating, it is pressed into containers and refrigerated. Because Lor is unsalted or mildly salted, its shelf life is brief. However, approximately 2–3% of the

cheese, salted and compressed into animal skins or earthenware jars, is preserved for an extended period of time. Cheese can also be produced by combining whey with a small amount of milk, so enhancing its flavor (Demirci et al., 1998, Kırđar & Gün, 1999). Due to its high moisture content, it has a short shelf life and is unsalted or barely salted. It is rich in protein, lactose, and some minerals (Ucuncu, 2004).

### 3.2. KOPANISTI CHEESE

The word kopanisti, derived from the Greek kopaniso, is kopanistos, and when translated into Turkish, it gains the meaning of “crushed, kneaded, beaten”. Kopanisti cheese, produced in Karaburun and Çeşme regions where animal husbandry was advanced in the years 1950-1960, was exported only to the Greek islands due to the lack of transportation. Kopanisti cheese on both the peninsula and the Greek islands shows that this product is the product of cultural interaction between Turks and Greeks. Kopanisti cheese is made from the lor obtained from the whey released in the production of Sepet cheese from goat’s milk. Cheese has yogurt consistency; its color varies between dark yellow and light brown. It has a taste reminiscent of Roqueforti cheese and appeals to a particular consumer segment due to its a salty, bitter taste with its acid flavor and sharp aroma. This review will focus on the production and properties of Turkish and Greek kopanisti cheese (Kırđar, 2020, Darcan et al., 2022).

The word kopanisti, derived from the Greek kopaniso, is kopanistos, and when translated into Turkish, it means “crushed, kneaded, beaten”. Although it is not difficult to make kopanisti cheese, which has a sharp smell, it is a cheese that requires patience and time (Dag, 2020). Kopanisti cheese, known as the cheese that rises as it is kneaded, is made in İzmir’s Çeşme, Karaburun, Foça and Urla districts, but today Kopanisti cheese is mostly made by a few families in Karaburun, Chios (Khios) and Lesbos (Lesbos) with traditional methods (Figure 1). It is not known in the villages (such as Reisdere, Ildırı, Uzunkuyu), where the Balkan immigrants settled here after the Greeks left the region. On the other hand, it appears as a traditional taste in many villages of Karaburun and Germiyan, Zeytineliler, and Kadiovacık, the settled Turkish villages that existed here a hundred years ago. (Kamber, 2005, Kırđar 2021). It has a taste reminiscent of Roqueforti cheese and appeals to a certain consumer segment due to its bitter taste. Kopanesti cheese, which is called “Tiryaki cheese”, is loved by the local people and consumed as an appetizer. (Kamber, 2008; Kırđar, 2021).

Kopanisti cheese is made from the lor obtained from the whey released in the production of Sepet cheese from goat’s milk. The main feature of its production is that the lor is transferred to earthen pots and kneaded in these pots until the desired sensory properties are obtained. In the production of

Kopanisti cheese, basket cheese is obtained by using goat's milk first, and the remaining whey is heated to 80-85°C in a separate boiler. In the meantime, 10-20% of fresh goat's milk is added, continuing the heating process. The heating is then stopped. After a while, the clot, which starts to collect on the surface, is transferred to the baskets. It is left to drain for a few days. It is then placed in cheesecloths and allowed to drain thoroughly. The curd obtained is taken into glazed and thoroughly cleaned earthenware pots called "Dahar" or "taar" and kneaded thoroughly. (Kırdar 2021)

The kneading process varies according to the season and takes 40 days in winter and 25 days if it is produced in summer. However, if the air temperature is low, the time between two kneading processes is longer, and if the air temperature is high, it is kneaded every day. In the last stages of the kneading process, the upper surface of the cheese acquires a shiny, slippery appearance, cracks appear in places, and it begins to emit a heavy odor. At this stage, salt is added to the cheese and kneaded again. The salting process is generally carried out in three phases. In the first salting, some salt is added to the cheeses, kneaded well, and left for three days. The second salting is done on the third day, and the third salting is done 7-10 days after that. The amount of added salt is at least 5% in dry matter. Kopanisti cheese, which can be consumed after the salting process, is stored in containers where the kneading process is done. As a final step, the top layer of the Kopanisti cheese is covered with olive oil and it is stored in a jar. Cheese has yogurt consistency; its color varies between dark yellow and light brown. It has a salty taste with its acid flavor and sharp aroma (Kırdar 2021).

Since Kopanisti is soft enough to be spread on bread, has a creamy consistency and a Roquefort flavor, it is generally used as an additive and appetizer. Especially as an appetizer, melon, raki, and Kopanisti are a traditional trio. Apart from breakfast, melon and white grapes are mixed with additives, especially in summer (Uhri, 2017; Onen, 2017).

### **3.3. KİRLİHANIM CHEESE**

Kirlihanım cheese is produced by Sepet Loru in the towns of Ayvalık, Foça, and Karaburun. It's a regional cheese unique to Anatolia. It alludes to the curd that is dried in Ayvalık. In reed baskets for a day, whole-fat ewe's or goat's whey is filtered to create a creamy-textured curd. It is then removed from the basket, sprinkled lightly with salt, and let to mature in a cool environment. The exterior layer of the cheese develops mold within 15 to 20 days, but the interior layers of the cheese stay white. Therefore, it is referred to as "Kirlihanım" (Dirty Lady). This unusual cheese from the Aegean Region is one of the less well-known cheeses in Anatolia because it is not produced in large quantities (Kirdar 2001).

The cheese is cleaned of any mould and eaten after that. Following the removal of the mold, the cheese is occasionally baked. When something is roasted, a crust develops and darkens on the top. Due to the mold on its surface, it is known as “kirlihanm.” It is a cheese with an erratic shape and a strong flavor. It resembles chocolate halva in appearance, is low in fat and gently salted, has dark dots on its surface (Kamber 2008). The chemical make-up of kirlihanm cheese was discovered to be moisture content 46.4%, fat-free dry matter 35.7%, fat 17.9%, protein 10.0%, and salt 4.9% by Akgün (1988).

### **3.4. SEPET (BASKET) LOR**

In both the Northern Aegean Region and the Southern Marmara Region, Sepet Loru Cheese is made, with the district of Ayvalık taking center stage. Turkey’s national cheese is this one. This cheese (Figure 1) is used to make the Kirlihanm cheese in addition to being enjoyed fresh. As with basket cheese (see Aegean Region Cheese), the cheese made using traditional curd cheese manufacturing techniques is prepared and then placed in baskets before being drained inside of them. Fresh cheese obtained in this manner is eaten. This variety of cheese has molds that are yellow-brown and purple. When making Sepet cheese, the whey is boiled, the curd is removed, salted with fine salt, and then put into “kovalk” baskets. This curd ripens for 6-7 months while occasionally being turned upside down. It dries for 1-2 weeks (Unsal, 2007).

### **3.5. SIRVATKA LOR CHEESE**

Bursa, Balkesir, Mustafakemalpaşa, Manyas, and Savastepe districts are all where srvatka-Lor cheese is produced. The whey cheese is also referred to as “srvatka” since it is created from the same whey that is used to make mihalic cheese. Srvatka lor cheese, which is made from the whey of Mihalic cheese, is superior to other whey cheeses in terms of quality. The cooked liquid that is left in the cask after the whey and curd obtained during the production of Mihalç Cheese are boiled is used to make this cheese. This variety of curd cheese, also known as Kelle or Mihalç Lor Cheese, is superior to other varieties of curd cheese in terms of quality. It smells almost like milk cream. It is a cheese that is highly valued while making böreks and other pastries (Kamber, 2007).

Srvatka lor tastes and smells a lot like milk cream. Its color varies in tone from bright white to off-white. The container’s form is apparent. It has a creamy, velvety, and smooth texture. They lack a rind and any gas-induced perforations. In addition to being used in pastry, pies, and numerous sweets, it is enjoyed fresh for breakfast on bread. It is regarded as “healthy” and is favored by bodybuilders due to its high whey protein, low fat, and low salt content (Ünsal, 2007, Kamber, 2007).

Sırvatka that is obtained during cheese-making is heated in large cauldrons until it curdles. The curdled content of the cauldron is left to coagulate for about 45 minutes. During this time, curd gathers on the surface. The curd that has accumulated on the surface is scooped up with ladles, poured onto the filtering cloth, and left to filter for one day. After this, it is salted with thin-grained salt at a ratio of half a kilogram to each tin can and a half, and then it is pressed tightly inside small wooden casks (a smaller type of the polam casks that are used in the making of Mihaliç Cheese). They are covered with white, oily sheets of paper, and their lids are shut tight. Weights are placed on them, and they are kept for 2 days, after which they are offered for consumption. This cheese may be consumed in various ways. It is eaten fresh at breakfast, or alternatively, it is salted, mixed with green peppers and spices, packed into jars, and left to mature before being consumed. It is generally consumed in the winter after being pickled in brine (18%) and preserved in a cool environment (Yöney, 1969, Kamber, 2007).

### **3.6. BROKEN KASHAR WITH LOR CHEESE**

The Bayburt province is responsible for the production of this cheese, which is typically created as a means of recycling Kashar Cheeses that are of high quality but have an undesirable shape by breaking them up in a machine. The curd cheese and Kashar cheese are both minced and then combined before being crushed together tightly inside of a wooden barrel, plastic drum, or bucket. After that, the containers are inverted and positioned above a mixture of wood sawdust and ash from the stove. This procedure takes place in a cool environment. The cheese will remain stored in this manner until the ash-sawdust mixture that is located under the container has become completely dry. This cheese, the flavors of which are a fusion of those of these two distinct types of cheese, is highly respected in the area (Unsal 2007, Kamber 2008) (Figure 1).

### **3.7. YUMME CHEESE**

The Yumme cheese is a specialty cheese produced in the province of Artvin. When the whey has been boiled for 15–20 minutes in a huge cauldron, milk that is one day old (from dawn to evening) is poured over it and the mixture is held over the flame for an additional 5 minutes. Buttermilk is allowed to curdle into a curd, and then it is cooled. After it has had time to cool, the curd is placed into a cloth bag, which is then hung in a relatively high location so that the liquid can drain off. After that, some cream is added to a pan, and the cheese is moved into the pan after the cream has been added. Salt is also added, and then the mixture is stirred continuously over a low flame for about half an hour. Once the cheese has matured to the desired consistency, it is pressed into a container, placed in

a refrigerator, and kept there until it is ready to be eaten (Figure 1). (Kamber & Terzi, 2007a)

### **3.8. NOR CHEESE**

The whey that is created during the process of manufacturing Hellim Cheese can be used to make a cheese called Nor Cheese, which is a curd cheese. In that part of the world, they also call it Karrisha Cheese (Kamber 2005).

### **3.9. EKSI (SIYAH) CHEESE (SOUR OR BLACK CHEESE)**

The whey that occurs during the making of Kesmük is used to make the sour or black cheese, which is a specialty of the province of Cankiri. This whey byproduct is placed into a pan and heated vigorously before boiling. Boiling continues until all of the whey has evaporated and the curd that is left has completely turned black. Boiling is halted once the curd has reached the appropriate color and consistency. Metal containers are used to store the cheese, which after cooling takes on the appearance of olive paste. The cheese, which resembles olive paste when cooled, is kept in metal canisters. This cheese is frequently eaten for breakfast by spreading it over a slice of bread and topping it with fenugreek, or it is used in cooking very much like a sauce (Kamber 2007b, Kırdar 2009).

### **3.10. DOLAZ CHEESE**

Dolaz cheese is a traditional cheese produced from whey by nomad (Karakoyunlu, Hayta, Honamlı, Sarıkeçili Yörüks) in the Lakes region (Isparta, Afyon and Antalya) in Turkey (Figure 1). It is generally made from ewe's and goat's milk. According to the information obtained from Karakoyunlu, Hayta, Honamlı and Sarıkeçili Yoruks living in and around Isparta, this cheese, which was produced more in the past, has not been produced much recently, especially due to the decrease in sheep and goat breeding (Okur & Seydim, 2011a,b).

Raw materials traditionally used in the production of Dolaz cheese are: whey (PAS) (53%), buttermilk (9.5%), optionally milk (10%), yoghurt (25%), and curd cheese (2 kg). In cheese production, the content is prepared and mixed in a cauldron before being heated over a wood fire. The contents of the boiler are mixed during the heat treatment with the help of a long, cylindrical wooden mixer, locally called a "bişsek." As the boiler content decreases, whey is added slowly, and the product is boiled until it turns a light yellow and brown and has the consistency of yoghurt (10–15 hours). After the heat treatment, the contents of the boiler are cooled and left for about 12 hours, and the product is transferred to the pouches to be filtered. Pre-maturation is carried out in the pouches for about 3–4 days, and at the end of the period, the product is taken from the pouches, salted

with normal table salt, and put back into the pouches, where it is kept for 5 days. At the end of the period, the product is taken from the pouches and pressed into the skins called “Tuluğ” (tulum). The skins used are a type of hairless leather called “white leather,” obtained from goat skin. Normally, these skins are not punctured, and excess water is removed when the skin is placed on its side by slightly tilting the arms. Coveralls are kept in cool rooms (15 °C) for 15–20 days (Okur & Seydim, 2011a,b).

### **3.11. ARMOLA CHEESE**

In the Seferihisar district of zmir, villages and small-scale dairy farms have been making the regional cheese known as Armola for many years. When making cheese, yogurt (20%), white cheese (20%), and Lor (60%) that have been individually kneaded are combined, put in a bag, and then hung to strain. The mixture was then immediately placed inside of a skin bag. The cheese was placed inside the open mouth of the skin bag, which was then sewn up to prevent the passage of air. The cheese-filled skin bag was hung in a cool, dry, and semi-dark setting to mature. It was securely secured with rope. To allow for maturation, armola cheese needs to be rested for at least a month. Due to whey leakage from the skin bag’s bottom during this time, the cheese develops a tougher structure. Three months were spent maturing the Armola cheese manufactured for the study (Kırdar et al. 2011, Kırdar & Camlıbel 2019, Yoldaş et al. 2019).

Seferihisar Armola cheese, which is purported to come from the Albanian culture, is a soft cheese unlike other traditional cheese varieties. It has a slightly salty and sour taste, spreadable consistency, and variable color from off white to slightly yellow. In Turkey, cheese is traditionally spread on bread and eaten at breakfast. As an option, olive oil, red pepper, and garlic can be added to a tomato salad and the cheese used as a sauce (Kırdar et al. 2011).

### **3.12. ŞOR LOR CHEESE**

It is a kind of Lor cheese produced in the Kars province. Cheese is obtained by heating the whey released in the production of cheddar cheese and the water in the boiling cauldron together. Because the boiling water is salty, cheese is called “or Curd.”(Kırdar, 2009).

### **3.13. İZMİR BIBERLİ (PEPPERED) LOR CHEESE**

İzmir Biberli Lor cheese bell pepper and chili pepper are sliced or added whole to the Lor cheese and preserved in plastic or earthenware jars. Optionally olive oil is added before consumption ( Karagozlu & Atilla et al 2014).

### **3.14. OTLU LOR (HERBY LOR) CHEESE**

Whey used in curd production is heated in large boilers and the proteins in its structure coagulate with the effect of heat, the residue is filtered and processed and curd is obtained (Demirci and Şimşek, 1997). Sometimes, 10-30% milk is added to whey as in the production of Ricotta cheese. 2-8% salt is added to the fresh lor cheese and mixed, then 10% thyme, mountain mint and herbs called mendo, sirmo and helis are added and mixed. Prepared herb curds are consumed after being pressed in overalls or plastic drums and matured for 2-3 months. These herbs not only give different taste, smell and aroma to the lora, but also add richness in terms of mineral substance content (Kamber 2007b, Kırđar, 2009).

### **3.15. TRAKYA LORU(THRACE WHEY CHEESE)**

Trakya loru (Thrace Whey cheese) is mainly produced in the Thrace region. It is made by whey of kashar cheese (Dinkci, 2020).

## REFERENCES

- Ak, S & Nergiz, C (1998).** *Investigation of chemical composition and microbiologic quality of Tire Çamur Cheese.* Vth.Milk and Milk products Symposium, 21-22 May, Tekirdağ p79-89.
- Akgün, C (1988).** *Traditional Turkish Cheeses and Production Techniques.* Ege University, Agriculture Faculty, Unpublished Graduation thesis, İzmir.
- Antunac, N., Hudik, S., Mikulec, N., Maletić, M., Horvat, I., Radeljević, B., & Havranek, J. (2011).** Proizvodnja i kemijski sastav Istarske i Paške skute. *Mljekarstvo: časopis za unaprjeđenje proizvodnje i prerade mlijeka*, 61(4), 326-335.
- Anand S., Chenchiah M., Som Nath K. (2013).** *Whey and Whey Products.* in: Milk and Dairy Products in Human Nutrition: Production, Composition and Health (eds. Y.W. Park and G.F.W. Haenlein). John Wiley & Sons, Oxford, pp. 477–492.
- Argenta, A.B.; Scheer, A.D.P. (2019).** Membrane separation processes applied to whey: A review. *Food Rev. Int.* 36, 1–30.
- Aydın, B., & Güneşer, O. (2021).** Manda Sütünden Üretilen Bazı Ürünlerin Duyusal Özellikleri. *Uşak Üniversitesi Fen ve Doğa Bilimleri Dergisi*, 5(1), 110-123.
- Backus, B. D., Clanton, C. J., Goodrich, P. R., & Morris, H. A. (1988).** Carbon-to-nitrogen ratio and hydraulic retention time effect on the anaerobic digestion of cheese whey. *Transactions of the ASAE*, 31(4), 1274-1282.
- Bakirci, I., Tarakci, Z., & Coskun, H. (1998).** *Van ve Yoresinde Üretilen Otlu Lorlar Üzerinde Bir Arastirma.* 5. Sut ve Sut Urunleri Sempozyumu (pp. 195–204). Ankara. doi:10.4012/ dmj.17.195
- Blažić, M., Pavić, K., Zavadlav, S., & Marčac, N. (2017).** The impact of traditional cheeses and whey on health. *Croatian journal of food science and technology*, 9(2), 198-203.
- Bojanic Rasovic, M., Nikolić, N., & Rasovic, R. (2017).** Quality of “urda” obtained after production of montenegrin semi-hard cheese. *Food Research.* 1 (5) : 166 – 170
- Burrington K. (1999).** *Whey products in baked goods.* U.S. Dairy Export Council, Applications Monographs. Bakery, pp. 1–8.
- Cakmakçı, S., Salık, M., (2021).** Türkiye'nin Coğrafi İşaretli Peynirleri. *Akademik Gıda* 19 (3) (2021) 325-342.
- Cardak, A. D. (2012).** Microbiological and chemical quality of cokelek cheese, lor cheese and torba (strained) yoghurt. *African Journal of Microbiology Research*, 6(45), 7278–7284.
- Demirci M, Şimşek O, Arıcı, M. (1991).** An investigation on composition and

some microbiological features of Lor marketed in Tekirdağ. *Gıda Derg.* 16 (5), 291-294.

**De Wit, J.N. (2001).** *Lecturer's Handbook on Whey and Whey Products*, first ed. European Whey Products Association, Brussels: Belgium.

**Dinkci, N. (2020).** Chapter 6: Traditional Cheeses of Marmara region in Turkey In: Current Development in Food and Nutrition Research Vol:1 142-169, Bentham Book Impress, ISBN:978-981-14-3235-4.

**Dragone, G., Mussatto, S. I., Oliveira, J. M., & Teixeira, J. A. (2009).** Characterisation of volatile compounds in an alcoholic beverage produced by whey fermentation. *Food Chemistry*, 112(4), 929-935.

**Drożdż A. (2007).** Żentyca – a Carpathian variety of Italian ricotta. *Prz. Hod.*, 9: 30-32.

**Ergullu, E., Kınık, Ö., Akbulut, N. (1988).** İzmir ili civarında üretilen Kopanisti peynirinin yapılışı ve özellikleri üzerinde bir araştırma. 5th. Süt ve Süt Ürünleri Sempozyumu, p.21-22.

**Filippetti, F., Giangolini, G., Boselli, C., Amatiste, S., Patriarca, D., & Rosati, R. (2007).** *Ricotta Romana: Manufacturing Technique, Chemical And Microbiological Composition. FIL-IDF World Dairy Summit and Exhibition.*

**Fisekci, B. (2013).** Effect of modified atmosphere packaging and CO<sub>2</sub> application on lor whey cheese shelf life (p. 5). (Master Thesis). Isparta, Turkey: University of Suleyman Demirel.

**García Bilbao, J.L., (1981).** Aprovechamiento de suero de leche desproteinizado y de materiales nitrogenados de desecho por algunas levaduras. *Alimentaria*, 119, 65-69.

**Ghaly, A.E., Kamal, M.A., (2004).** Submerged yeast fermentation of acid cheese whey for protein production and pollution potential reduction. *Water Research*, 38 (3), 631-644

**Galus S., Kadzińska J.(2016).** Whey protein edible fi lms modifi ed with almond and walnut oils. *Food Hydrocolloid*, 52, 78–86.

**Guerrini, P., Prost, J. A., Maïzi, P. M., de Sainte Marie, C., Geslin, P., Muchnik, J., & Sautier, D. (2001).** *Implementation of controls for Corsican Brocciu, an AOC whey-cheese. ISBN:*

2-7380-1015-6

**Guo, M.; Wang, G.(2019).** History of Whey Production and Whey Protein Manufacturing. In *Whey Protein Production, Chemistry, Functionality, and Applications*; Guo, M., Ed.; John Wiley & Sons: Hoboken, NJ, USA, 2019; pp. 1–12

**Jassen-Escudero C. and Rodriguez-Amaya D.B. (1981).** Composition of the Brazilian cheese “Requeijão do Norte.” *Journal of Food Science* 46: 917-919.

- Jyry, A. (2021).** *Ziger whey cheese and its manufacture*. Master's Thesis ISSN 0355-1180.
- Kamber, U.(2005).** *Geleneksel Anadolu peynirleri*. Ankara: Miki Matbabcılık, p. 223
- Kamber, U. (2007a).** The traditional cheeses of Turkey:“Marmara region”. *Food Reviews International*, 24(1), 175-192.
- Kamber, U. (2007b).** The traditional cheeses of Turkey: eastern Anatolia region. *Food Reviews International*, 24(1), 148-174.
- Kamber, U., & Terzi, G. (2007a).** The traditional cheeses of Turkey: Middle and Eastern Black sea region. *Food Reviews International*, 24(1), 95-118.
- Kamber, U., & Terzi, G. (2007b).** The traditional cheeses of Turkey: Central Anatolian region. *Food Reviews International*, 24(1), 74-94.
- Kandarakis J.G. (1986).** *Traditional whey cheeses*. Bulletin of the International Dairy Federation 202: 118-123.
- Karagözlü, C., Yerlikaya, O., Akpınar, A., Gülfem, Ü. N. A. L., Ergönül, B., Ender, G., & Uysal, H. R. (2016).** Cholesterol levels and some nutritional parameters of traditional cheeses in Turkey. *Ege Üniversitesi Ziraat Fakültesi Dergisi*, 53(2), 161-168.
- Karagözlü C., Atilla, N. (2014).** *Peyniraltı suyunun değerlendirilmesinde Alternatifler: Geleneksel peynirler ve peyniraltı suyu içecekleri*. 4.geleneksel Gıdalar Sempozyumu Bildiri Kitabı 17-19 Nisan, Adana.
- Kawęcka, A., & Pasternak, M. (2020).** Nutritional Value Of Żyntyca, Traditional Polish Sheep Whey Product–Preliminary Results. *Journal of Elementology*, 25(4).1509-1516.
- Keaton J. (1999).**Whey protein and lactose products in processed meats [online]. U.S. Dairy Export Council: Applications Monographs. Meats Available at: [<http://www.usdec.org/files/pdfs/6meat.pdf>].
- Kırdar, S., Gün, İ., (1999).** Burdur halk pazarında satılan lor peynirlerinin hijyenik kalitesi üzerine bir araştırma. *Gıda Bilimi ve Teknolojisi Dergisi*, 4(2):44-47.
- Kırdar, S. S. (2009).** *Peyniraltı Suyundan Üretilen Geleneksel Peynirlerimiz*, II. Geleneksel Gıdalar Sempozyumu, 27-29 Mayıs, Van, p739-742.
- Kırdar, S.S., Girgin İ., G Yeşilcam.(2011).** *Traditional Turkish Goat's Cheese: Armola Cheese*. 4th International Congress on Food and Nutrition, Istanbul, 2011, pp.77-78. [2].
- Kırdar, S.S. (2014).** Armola Peyniri Üretim Teknolojisi. 4. Geleneksel Gıdalar Sempozyumu, Adana, 2014, pp265-268.
- Kırdar, S. S., & Çamlıbel, Z. (2019).** Profiles of the Biogenic Amines in Armola Cheese. *European Journal of Advances in Engineering and Technology*, 6(12), 80-84.

- Kırdar, S.S., 2021.** Cheese Embracing Both Sides Of The Aegean Sea: Kopanıstı Cheese. *World Journal of Engineering Research and Technology*, 7(6), 265-278.
- Królczyk, J. B., Dawidziuk, T., Janiszewska-Turak, E., & Solowiej, B. (2016).** Use of whey and whey preparations in the food industry-a review. *Polish Journal of Food and Nutrition Sciences*, 66(3), 157.
- Kisaalita, W.S., Lo, K.V., Pinder, K.L., (1990).** Influence of whey protein on continuous acidogenic degradation of lactose. *Biotechnology Bioengineering*, 36 (6), 642-646.
- Kosikowski, F.V., Wierzbicki, L.E., (1973).** Research-article: lactose hydrolysis of raw and pasteurized milks by *Saccharomyces lactis* lactase. *Journal of Dairy Science*, 56 (1), 146-148.
- Kosikowski, F.V., 1979.** Whey utilization and whey products. *Journal of Dairy Science*, 62, 1149-1160
- Kosikowski F.V. (1982).** *Whey cheese*. In: Kosikowski, F.V. and Associates (eds.), *Cheese and Fermented Milk Foods*. New York: Edwards Brothers, pp. 367-373.
- Lioliou, K., Litopoulou-Tzanetaki, E., Tzanetakis, N., & Robinson, R. K. (2001).** Changes in the microflora of Manouri, a traditional Greek whey cheese, during storage. *International Journal of Dairy Technology*, 54(3), 100-106.
- Lucey, J. A. (2011).** Encyclopaedia of dairy science, cheese/acid- and acid/heat coagulated cheese (2nd ed., pp. 698–705). Amsterdam: Academic Press.
- Mahran, G.A.; Hammad, Y.A., Nawal S. Ahmed; Saged, A.F and Abd El-Aziz, M. (1999).** Manufacture of Ricotta Cheese from whey fortifier with skim milk powder using different acidulant . *Egyptian Journal of Dairy Science*, 27:191.
- Malcata F.X. (1991).** *Hydrolysis of Butterfat by Immobilized Lipase Using Three-Phase Membrane Reactors*. Ph.D. Thesis University of Wisconsin, Madison, WI, USA.
- Medina, M., Nunez, M.(2017).** *Cheese* (Fourth Edition). In: Chapter 41. Cheese From Ewe and Goat Milk, p1069-1091.
- Okur, Ö. D., & Güzel-Seydim, Z. (2011a).** Determination of some characteristic properties in traditional Dolaz cheese. *Ege Üniversitesi Ziraat Fakültesi Dergisi*, 48(2), 111-115.
- Okur, Ö. D., & Güzel-Seydim, Z. (2011b).** Determination of production method, microbial and volatile flavor components and sensory properties of traditional Dolaz cheese. *GIDA-Journal of Food*, 36(2), 83-88.
- Orşahin, H. (2012).** *Quality Characteristics and Shelf-Life of Armolat Cheese* (Doctoral dissertation, Izmir Institute of Technology (Turkey)).
- Önen, E.(2017).** Türk ve Rumların yarımada 'da birlikte yaşadıkları dönemin

- kültürel izleri: Germiyan köyünden örnekler. *Sosyoloji Dergisi*, (35):1-19
- Panesar, P. S., Kennedy, J. F., Gandhi, D. N., & Bunko, K. (2007).** Bioutilisation of whey for lactic acid production. *Food chemistry*, 105(1), 1-14.
- Papademas, P., Bintsis, T., Alichanidis, E., & Ardö, Y. (2017).** Whey cheeses (heat coagulated). *Global Cheesemaking Technology: Cheese Quality and Characteristics*, 446-452.
- Philippopoulos C.D., Papadakis M.T.(2001).** Current trends in whey processing and utilization in Greece. *International of Journal of Dairy Technology*, 54, 14–19.
- Pintado, M.E., Macedo, A.C., Malcata, F.X. (2001).** Review: Technology, chemistry and microbiology of whey cheeses. *Food Science Technology International*, 7 (2):105-116.
- Prazeres, A. R., Carvalho, F., & Rivas, J. (2012).** Cheese whey management: A review. *Journal of environmental management*, 110, 48-68.
- Prabhu G. (2006).** U.S. Whey proteins in processed meats. U.S. Dairy Export Council, Applications Monographs. Processed meats. Pp. 1–12.
- Rako, A., Tudor Kalit, M., Kalit, S., Soldo, B., Ljubenkov, I. (2018).** Nutritional characteristics of Croatian whey cheese (Bračka skuta) produced in different stages of lactation. *LWT-Food Science and Technology*, 96, 657-662.
- Rubel, I.A., Iraporda, C., Gallo, A., Manrique, G.D., Genovese, D.B. (2019).** Spreadable ricotta cheese with hydrocolloids: Effect on physicochemical and rheological properties. *International Dairy Journal*, 2019; 94, 7-15
- Ryan, M.P.(2016).** Walsh, G. The biotechnological potential of whey. *Rev. Environ. Sci. Bio Technol.* 2016, 15, 479–498.
- Salvatore E., Pes M., Falchi G., Pagnozzi D., Furesi S., Fiori M., Roggio T., Addis M.F., Pirisi A. (2014).** Effect of whey concentration on protein recovery in fresh ovine ricotta cheese. *Journal of Dairy Science*, 97, 4686–4694.
- Scatassa M. L., Mancuso I., Sciortino S., Macaluso G., Palmeri M., Arcuri L., Todaro M., Cardamone C. (2018).** Retrospective study on the hygienic quality of fresh ricotta cheeses produced in Sicily, Italy. *Italian Journal of Food Safe*, 7(1): 6911.
- Siso, M. G. (1996).** The biotechnological utilization of cheese whey: a review. *Bioresource technology*, 57(1), 1-11.
- Stefanovic R. and Djordjevic D.J. (1969).** Production and processing of ewe's milk in Yugoslavia. In: *Proceedings of the First Conference on Processing of Ewe's Milk*, Zilina, Czechoslovakia, pp. 51-59.
- Tratnik, L.J. (2003).** Uloga sirutke u proizvodnji funkcionalne mliječne hrane. *Mljekarstvo* 53 (4), 325-352.
- Temiz, H., Aykut, U., & Hursit, A. (2009).** Shelf life of Turkish whey cheese

- (Lor) under modified atmosphere packaging. *International Journal of Dairy Technology*, 62, 378–386. doi:10.1111/idt.2009.62.issue-3
- TEPGE, 2020. Durum ve Tahmin Süt ve Süt Ürünleri 2020. TEPGE Yayın No:321, ISBN:978-605-7599-48-3.49s.
- Tripaldi, C., Rinaldi, S., Palocci, G., Di Giovanni, S., Campagna, M. C., Di Russo, C., & Zottola, T. (2020).** Chemical and microbiological characteristics of homogenised ricotta cheese produced from buffalo whey. *Italian Journal of Food Science*, 32(2),292-309.
- Uhri, A. (2017).** “Armola ve Kopanisti Üzerinden Peynirin Serüveni”. Gastro Metro Dergisi. (Doğan Ofset Yayıncılık ve Matbaacılık, İstanbul).
- Tonguç İ E and Karagözlü C.(2012).** Peyniraltı Suyu Peyniri: Ricotta, *Süt Dünyası Dergisi*, 7(36): 50-53.
- Ucuncu, M. (2004).** *Cheese technology* (Lor cheese, Ed). Izmir, Turkey: Meta Publ
- Ünsal, A. 2007.** When Milk Slept “Turkish Cheeses,” Bank of Yapi Kredi Publications: Istanbul,
- Wendorff W. (2008).** Uses of whey in the farmstead setting. The University of Wisconsin-Madison. Available at: [http://future.aae.wisc.edu/publications/farmstead\\_whey\\_use.pdf](http://future.aae.wisc.edu/publications/farmstead_whey_use.pdf)].
- Williams M.R. and Syson R. (1984).** The bacteriological quality of Cyprus cheese. *Environmental Health* 92: 146-149.
- Yoldaş, M., Kınık, Ö., Akan, E., & Yerlikaya, O. (2019).** A traditional cheese from Greece to Turkey: Armola. *International Journal of Dairy Technology*, 72(4), 601-609.
- Young S. (1999),** *Whey products in cold pack pasteurized processed cheese foods and cheese spreads*. U.S. Dairy Export Council, Applications Monograph. Processed cheese. pp. 1–8.
- Zerfiridis, K. G., Manolkidis, S. K., & Samolada, S. M. (1985).** The Greek whey cheeses and improvements in the technology of recovering proteins from whey of sheep and goats milk. *Deltio Ethnikis Epitropis Galaktos Elladas (Greece)*.